

# WANTOK

NIUSPEPA BILONG OL PAPUA NIUGINI STRET

Ernst & Young audited/  
circulation 15,177

40 pes

Namba 951

Wik i stat long Fonde, Septemba 24, 1992.

40 toea

## Moa indai gen long Bogenvil

I GAT ripot i kamap nau olsem ol soldia bilong Papua Niugini Difens Fos (PNGDF) i bin kilim tripela man long mun Ogas.

Tupela em ol wokman bilong Katolik Misin long Tubiana. Dispela tupela man em Michael Vinas bilong ples Selau long Buka na i marit long Pokpok. Narapela man em Kevin Kabu.

Ripot i tok dispela tupela man i bin go long Solomon Ailan long baim ol samting olsem marasin na klos na laik go bek long Bogenvil long wanpela moto kanu. Long haprot, wanpela bot bilong ol ami i kamap na kisim dispela tupela man. Ripot i tok ol i bringim tupela i go long Taurato Ailan

Insait long moto kanu bilong tupela i bin gat ol marasin, kaikai, klos, ol pas na bensin. Tasol bihain long Ogas 29, no gat wanpela tok klia i kamap bilong tok save olsem tupela i stap laip yet o nogat.

Wanpela ripot i kam long Solomon Ailan i tok ol i bilip olsem dispela tupela man i dai pinis. Bikos namba wan ripot i bin tok olsem tupela i stap kalabus long Taurato Ailan. Tasol nau ripot i tok ol i no stap moa long hap.

Long bihainim dispela toktok na painimaut long indai bilong tupela man ya, Distrik Supavaisa bilong ol Marist Bruder, Bruder Desmond Howard i bin salim wanpela pas i go long Komanda bilong PNGDF long Mosbi long sekap long dispela samting.

Long dispela pas bilong Bruder Desmond bilong i go moa long pes 4



*Fri sofdring long 2 mail...*Wanpela bikpela kontena ka bilong Pangia Construction i karim ol Pepsi sofdring i laik go olsem long taun long asde tasol stia i abrus na go daun long sait bilong 2 mail maunten long Mosbi. Laki tru olsem ka i pas long ol diwai. Draiva i kisim bagarap na i slip nau long haus sik. Ol plisman olsem Max Kiwa i kamap hariap na stapim ol pipel long kisim ol samting. Tasol sampela sofdring i lus pinis. *Poto: Godfried Niaka.*

# AIR NIUGINI KISIM KOT ODA

...husat i brukim oda bai go kalabus

CLEMENT MIRIA i raitim

AIR Niugini i no inap bihainim wanpela gridi askim bilong ol wokman.

Na em i laikim olgeta wokman long kamap wok stat long tude na tumora. Husat i no kamap long wok bai kisim taim.

Ol bos bilong Air Niugini i tok dispela 48 awa straik em ol lain bilong Nesenel Airline employis Asosiesen na PNG Flait Atentens Asosiesen i kamapim long Tunde i brukim lo.

Na Air Niugini i go het na kisim narapela kot oda gen long surikim tambu long dispela straik. Kot oda bilong Nesenel Kot i tok olsem dispela straik bilong Ogas 27 i no bihainim lo. Na dispela oda bai stap inap long tumora.

- Ol toktok long kot oda i tok:
- Air Niugini na Nesenel Airline Asosiesen i mas pinisim nau ol toktok bilong pasim wok;
- Ol opisa na eksekutiv bilong asosiesen i no ken grisim na suvim ol wokman long straik; na

• Ol opisa bilong asosiesen i mas bihainim olgeta toktok i kam long dipatmen bilong Leba na Emploimen.

Bikpela tok lukaut i stap olsem ol eksekutiv bilong Nesenel Airline Employis Asosiesen olsem Kapai Aria, Philip Pyaso, Richard Pangwinyen, Gabi Lewa na Opu Mariosu bai go kalabus sapos ol i no bihainim kot oda. Ol narapela memba bilong asosiesen tu bai go kalabus sapos ol i stap long straik yet.

Menesmen i tok dispela liklik hevi bilong apim pe long 15 pesen i bruk na kamap bikpela samting olgeta. Na nau ol wokman i laik pasim ol ron bilong ol balus.

Long Septemba 4, ol yunien memba bilong Air Niugini na NAEA i bin lusim wok bikos ol i no amamas long kain pe ol kontrak opisa bilong ovasis i kisim wantaim ol nesenel menesa na ol narapela wokman. NAEA i tok long 1990 na 1991,

ol ovasis kontrak opisa i bin kisim narapela 24 pesen antap long pe bilong ol. Na ol sinia nesenel menesa i bin kisim 22.5 pesen bihain long ol i toktok long straik.

Na NAEA i laikim olsem dispela bikpela mak namel long ol pe bilong ol nesenel menesa, ol kontrak opisa na ol arapela wokman i mas kam daun liklik.

Jenerel Seketeri bilong NAEA, Kapai Aria i tok long asde olsem hevi nau i no stap long 15 pesen moa long pe tasol. Nogat. Straik nau i sut long tingting olsem Air Niugini i mas kisim bek ol 78 i go moa long pes 2



**HINO. BOS BILONG OL HAIWE.**

**Hino**

**Ela Motors**

PORT MORESBY 229400 • LAE 433655 • RABAU 921988 • MADANG 822188 • GOROKA 721844 • MT HAGEN 521888  
WEWAK 862255 • KAVIENG 942132 • KIMBE 935155 • TABUBIL 589060 • VANIMO 871254 • PORGERA 579367

# Australia plis holim Mosbi bisnisman wantaim spakbrus

OL plisman long Papua Niugini na Australia i painimaut yet long ol wok bilong wanpela bisnisman bilong Mosbi, Julian Paul Leach.

Long Jun 27, ol plisman i bin holim Leach long Brisben ples balus long kisim spakbrus i go long Australia. Orait bihain plis long Nu Saut Wels i laikim Leach i go kot long Sidni bikos trabel i bin kamap long hap.

Ripot i tok ol plisman i sekim wanpela haus long Sidni na painim ol spakbrus. Hevi bilong dispela em inap long 19 kilogram. Plis i bilip olsem Leach i kisim ol dispela spakbrus long Papua Niugini bilong salim long Australia. Na sapos em i salim, em bai kisim samting olsem K300,000.

Leach i kamap long kot na baim K10,000 bilong go wetim kot bilong em gen. Na em i baim tu narapela K50,000 bilong bringim spakbrus long wan-

pela kantri i go long narapela.

Kot bilong em bai kamap gen sampela taim long dispela yia.

Plis i holim Leach bihainim gutpela wokbung namel long nesanel Drag Skwat bilong Papua Niugini na ol Australia Drag Ejensi.

Long dispela taim plis i bin holim Leach i kam inap nau, ol lain long plis, takis opis na kastoms i wok long sekap gut long ol kain bisnis bilong Leach long Papua Niugini. Ol i kisim pinis wanpela gutpela bot na ol narapela samting. Na ol i givim oda tu long tambuim olgeta samting em i stap long nem bilong Leach insait long kantri. Dispela tambu i karamapim tu ol manj bilong em long beng.

Plis long Australia na Papua Niugini i wok long sekap yet long ol bisnis bilong Leach long PNG na Australia.

Plisman wok han nating na slip long haus sik

WANPELA plisman i stap nau long bikpela hus sik long Goroka bihain long ol raskol i sutim em long gan.

Dispela birua i bin kamap long las wiken taim sampela man i brukim Lamana Holsel stua long Wes Goroka na stilim ol samting.

Plis i no save yet long kos bilong ol samting ol i bin stilim. Wanpela plisman husat i bin go long dispela hap long sekap bihain long wanpela sekyuriti i ringim ol nau i stap long haus sik. Ol raskol i bin sutim em long gan.

Bos bilong ol plis long Hailans rijon, Bunu Katusela i tok ol dispela lain man i bin go insait long stua bihain long ol i brukim windo long baksait long hap bilong toilet. Ol i brukim flai waia na kamautim ol glas na kalap i go insait na stilim ol samting.

Taim sekyuriti i lukim olsem, em i ringim ol plis.

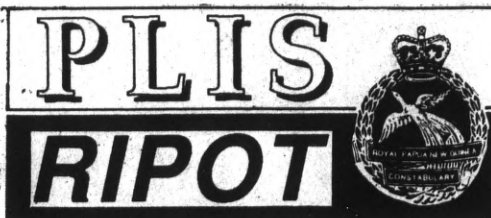

**MOSBI:** Plis i sasim pinis wanpela meri long kilim dai narapela bihain long tupela i kros long wanpela man. Meri ya em Anna Laiam Inapi husat i gat 30 krismas na i bilong Tapini long Sentrel provins. Na meri em i kilim em Clotilde Inapi husat i gat 30 krismas bilong Bereina long Sentrel provins. Tupela meri ya i maritim wanpela man. Plis i tok tupela i wok long kros long ai bilong man bilong ol taim Anna i rausim naip long bilum na sutim Clotilde long nek bilong em na kilim em i dai.

**MOSBI:** Tripela stil pasin i bin kamap long Mande Septemba 21. Wanpela i bin kamap long Ela Beach we foapela man i karim gan na naip na hensapim ol wokman bilong Lika Ban stua na kisim mani na sek bilong stua na ranawe. Narapela i bin kamap we ol raskol i hensapim wanpela man long haus bilong em na stilim ka bilong em. Long dispela taim yet, wanpela man i bin draiv i go long lukim pren bilong em taim ol raskol i hensapim em na stilim ka bilong em. Plis i painimaut yet long dispela.

**HAGEN:** Tupela meri i bin dai bihain long ka i bamim ol taim ol i laik wokabaut i go long hap-sait long rot bilong Kindeng long Sande, Septemba 19. Tupela meri ya i bilong ples Kindeng na nem bilong ol em Kun Yubo husat i gat 22 krismas na Noma Kewa, 21 krismas. Plis i holim pinis na sasim man husat i bin draivim ka na kilim ol meri ya.

**HAGEN:** Plis i painimaut nau long wanpela ripot sampela lain i bin kilim wanpela man bilong ples Korowa long Tambul long bekim dai bilong arapela wan lain bilong ol. Man husat i dai em Wakapu Sipuka. Plis i holim pinis wanpela man ol i bilip i bin stap insait long dispela birua.

**HAGEN:** Long las wiken, ol raskol i bin brukim wanpela haus long Warakum na hensapim wanpela man na bagarapim meri bilong em. Long wankain taim tu, ol boskru bilong wanpela PMV bas i bin bagarapim wanpela meri ol i kisim olsem pasindia long bas bilong ol. Plis i painimaut yet long dispela tupela trabel.

**MOSBI:** Long las wik Fonde, Septemba 17, tripela man i bin bagarapim wanpela meri Simbu long Morata No.3. Plis i tok meri ya i bin wokabaut wantaim boipren bilong em taim tripela man i stapim na ronim ol. Ol i holim meri ya na bagarapim em. Na bihain ol i ranawe long wanpela ka. Plis i holim pinis wanpela long ol man ya na i wok long painim yet tupela narapela.

**MOSBI:** Long Fraide Septemba 18, ol raskol i bin brukim wanpela stua long Morata na stilim 30 katen bia, K120 na ol kaikai inap long kos bilong K500. Papa bilong stua i bin slip i stap taim trabel ya i kamap. Na plis i holim pinis wanpela man na ol i painimaut yet long dispela trabel.

**MOSBI:** Wanpela man i stap nau long haus sik bihain long ol i sutim bel bilong em long spia insait long wanpela pait. Pait ya i bin kamap namel long ol pipel bilong Isten Hailans na Enga. Plis i tok pait ya i kamap taim ol lain bilong wanpela provins ya i spak long 5 mail setelmen na kros. Plis i go long hap na stapim dispela hevi taim ol i kisim ripot.

**TARI:** Independens De selebresen long Fonde i bin bagarap bihain long ol pipel i brukim nabaut Bromley na Manton stua. Wanpela wokman i bin kisim bagarap long dispela taim. Plis i tok olsem moa long 100 pipel i bin go insait long stua na kisim ol samting. Provinsal Plis Komanda Gary Baki i tok dispela i bin kamap bikos ol pipel i bel hat long stua ya i op long pablik holide.

## Raskol pasin kamp bikpela namel long Hagen na Mendi

OL plis na wokman bilong gavman i mas mekim sampela samting long traim na stapim ol trabel nau i wok long kamap long rot namel long Mendi na Hagen.

Ol hap ples we trabel i wok long kamap bikpela nau em Togoba na lalibu.

Dispela em toktok bilong wanpela opisa bilong Tiong Seng Contractors Pty, Limited Peter Karaput. Em i tok raskol pasin long hap i wok long kamap bikpela. Na nau planti lain i save raun long dispela hap wantaim pret.

Karaput i tok kampani em i wok long en nau i wok long stretim rot long hap. Tasol sapos ol loman i no mekim wanpela samting, i luk olsem wok long dispela rot bai stop na ol i no inap pinisim.

"Ol raskol long dispela hap i save karim ol sotgan na mekim ol samting long laik bilong ol. Ol i save pasim ol ka na stilim ol samting bilong ol draiva na ol pasindia, bagarapim ol meri, paitim ol manmeri nabaut na sutim ol ka long dispela rot," Karaput i tok.

Em i tok i no longtaim tasol, tupela wokman bilong Tiong Seng i bin kisim bagarap long hap bilong ol dispela raskol.

# Air Niugini kisim kot oda

i kam long pes 1

membra bilong NAEA husat em i rausim long Mande.

Na em i tok asosiesen i pret tu olsem menesmen bai rausim narapela 100 wasman na meri bilong balus tude o tumora.

Mista Aria i givim tok lukaut long ol arapela manmeri long no ken traim ron long Air Niugini balus long dispela taim. Bikos nogut i gat bagarap na nogat man bai sambai long helpim ol.

Long asde apinun, minista i bosim wok bilong ol balus, Tim Neville i bin tok save long Prais Minista Paias Wingti long dispela. Tasol no gat wanpela ripot i kamap yet long en.

Na long asde, wanpela traibunel i wok long harim dispela hevi bilong 15 pesen moa pe i pasim kibung.

Em bai bung gen tude na toktok long ol samting sapos Air Niugini bai kisim bek ol wokman em i rausim o nogat.



*Bilum na hat bisnis long Mosbi....Anthonia Paul bilong Is Sepik provins i salim bilum na hat em yet i wokim long Waigani Ats senta. Anthonia i save wok wantaim Ombutsmen Komisen long Mosbi. Foto: Winis Map.*

# Ol stilman kisim K7,405 long PNGBC Maprik

## GODRFIED NIAKA i rattim

SAMPELA man i stilim K7,405 long Papua Niugini Benking Kopresen opis long Maprik, Is Sepik provins.

Ol dispela man i bin hensapim ol wokman bilong beng na kisim dispela mani long las wik Tunde moning. Trabel i bin kamap long 10 klok moning.

Provinsal Plis Komanda (PPC) bilong Is Sepik, Sief

Inspekta John Wakon i tok 9-pela man i go hensapim ol wokman insait long beng na kisim wanpela beg mani na ranawe. Insait long en i gat K7,405.

PPC Wakon i tok pastaim long dispela i kamap, ol dispela lain man i bin hensapim menesa bilong Elcom long Maprik na kisim ka bilong em namel long Heifil stesin na Maprik taun. Na bihain ol i go long beng na stilim mani na ranawe long ka.

Em i tok olsem ol dispela man i bin yusim tripela sotgan wantaim ol naip long pretim ol wokman na kisim mani. Ol plisman bilong Maprik i kamap tasol ol stilman i ranawe pinis.

Na ol i painimaut yet long dispela.

Long narapela birua, Inspekta Wakon i tok sampela man i bin kilim wanpela yangpela man na tromol bodi bilong em namel long maus rot bilong Wom na Yarapos haiskul.

Em i tok dispela birua i bin

kamap long las wik Trinde long nait. Nem bilong dispela man em Joseph Wari, husat i gat 22 krismas na em i bilong ples Handra long Kubalia.

Wakon i tok ol man husat i kilim Wari i bin yusim wanpela samting olsem tamiok long brukim het bilong em. Na tu ol i katim wanpela han na lek bilong em.

Na ol plisman i painimaut tu long dispela.

Madang pretim tokorait bilong Wingti gavman

# Sepik disasta komiti gat K79,000 dinau

MESERY GUBAG I raitim

WOK bilong kirapim faktori bilong putim ol tuna na tangir pis long tin long Madang bai stat long mun Oktoba. Na olgeta wok bai pinis bihain long wanpela yia.

Ol wok bilong mekim em long joinim pawa saplai i go long Aleksisafen, wokim ol haus bilong putim ol samting, rot, stretim ples bilong wokim bris, wara saplai na faktori yet.

Madang provinsal gavman na Dipatmen bilong Madang long nau yet i wok long pret long wanem, nesanel gavman i tok no gat long dispela faktori long kamap long Madang.

Madang provinsal gavman i tingting olsem nogut bai nesanel gavman i tok long kirapim dispela faktori long Nu Ailan provins. Bikos dispela em tingting bilong praim minista Paias Wingti long senisim olgeta tokorait gavman bilong olpela praim minista, Rabbie Namaliu i bin mekim.

Dispela faktori long Madang taim olgeta wok i pinis bai wokim tuna na tangir tin pis na salim i go long ol arapela kantri na insait long kantri wantaim.

Ol tuna na tangir pis bai i kam long Z kampani husat i wok bung long sanapim na ranim dispela faktori.

Taim nesanel gavman na Madang provinsal gavman i tokorait wantaim papa bilong Z kampani, Lawrence Zuanich, tupela i tokorait long Z kampani long painim pis insait long solwara bilong Papua Niugini.

IS Sepik Provinsal Disasta Komiti i gat moa long K79,000 dinau mani long ol praivet kampani insait long provins.

Tasol provinsal gavman na provinsal disasta komiti i nogat mani long bekim dispela ol dinau. Dispela dinau i kam long ol samting ol i bin kisim long ol stua na sevis

stesis long helpim ol pipel taim Sepik Wara i bagarapim ol pipel long hap.

Kos bilong ol dinau bilong ol long wanwan kampani we ol i bin kisim ol samting long em: Garamut Enterprise - K39,000, Shell - K7,000, Mobil - K15,000, ol ka na bot ol i bin kisim long haia - K8,000, pe bilong ol

pipel husat i bin wok long taim bilong hai wara - K10,000. Dispela olgeta lain i no kisim pe bilong ol long gavman yet.

Dispela yia long Me, Nesanel Disasta na Seveilens Komiti (NDSC) i bin givim K60,000 long helpim na stretim ol kain hevi olsem, na baim sampela moa samting bilong helpim ol pipel ya. Tasol dispela mani i no inap na ol i yusim pinis.

Long las wik, kodineta bilong provinsal disasta komiti, Bella Seiloni i salim wanpela ripot i go long Dairekta Jenerel bilong NDSC, Leith Anderson na toksave long em long dispela hevi bilong ol. Em i givim tu ripot bilong we ol i yusim dispela K60,000, na askim sapos ol inap long givim sampela mani long komiti bilong em long bekim dispela ol dinau.

Long dispela wik tasol, em i ring long painimaut long bekim bilong leta bilong em. Em i harim olsem askim bilong em i mas wet inap taim gavman i mekim nupela baset bilong 1993 yia. Seiloni i tok dispela i orait na em i ken wet. Tasol bikpela tingting bilong Seiloni em long ol kampani.

"Bikos dispela ol lain mas i gat mani long ranim bisnis bilong ol i go moa long pes 19

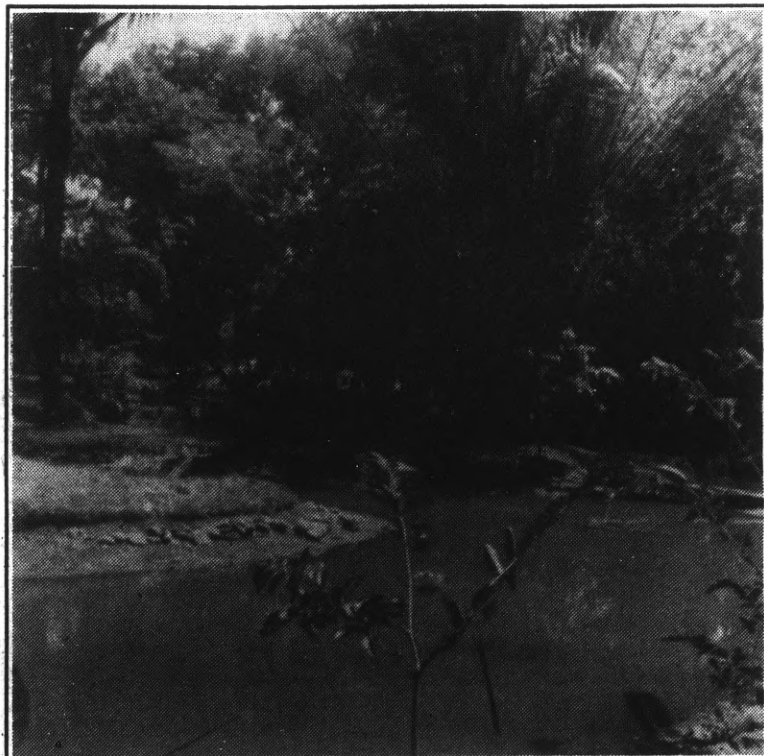

Ol pis i go we...Bipo dispela raunwara long Lae Botanikel Gaden i save pulap tru long ol kain kain pis. Tasol nau em i silp sore i stap. Bikos i no gat man i stap moa long hap bilong lukautim dispela bikpela plawa gaden na ol samting insait long en. Foto: Sape Metta.

# NUS laik kirapim opis long Mosbi

NESENEL Yunien bilong ol Studen (NUS) i tingting long sanapim wanpela opis long Mosbi.

Dispela opis bai lukluk long sindaun bilong ol studen long olgeta koles na yunivesiti insait long kantri, na mekim wok bilong ol. Jenerel seketeri bilong NUS, Noah Musingku i tokaut olsem.

Em i tok dispela opis em i wanpela bikpela samting. Bikos em bai karimaut tingting bilong ol studen. Em i tok lo bilong NUS i tok olsem mas i gat wanpela opis bilong ol.

Tasol nau yet i nogat opis. Na ol studen ripresentativ kaunsil bilong wanwan koles na yunivesiti i save mekim wok bilong NUS. Dispela i save givim planti hatwok long ol studen.

Em i tok opis bilong NUS bai stap long Mosbi. Bikos Mosbi em hetkwata bilong olgeta gavman dipatmen na praivet kampani.

# Moa pipel wet yet long kisim mani long pablik kureta opis

MOA long 289 pipel bilong Madang i wetim yet mani bilong ol long opis bilong Pablik Kureta long Lae.

Opis bilong pablik kureta em ples we ol pipel i save bringim ol leta o pasbuk na aplai long kisim mani bilong ol famili i dai pinis.

Wanpela opisa long distrik opis long Madang i tok planti pipel i wok long i go i kam long opis bilong ol na askim long mani bilong ol. Sampela i givim aplikesen long 1989 yet.

Opis long Madang i save kisim aplikesen na salim i go long bikpela opis long Lae, we ol bai givim tok orait long ol pipel i ken kisim mani. "Mipela i wok long salim ol lain i go bek long ples i go moa long pes 19

# Bikpela enimel bilong solwara sua long Nusa

LONG Trinde Septemba 16, ol manmeri long Kavieng i go pulap long Nusa bris long lukim wanpela bikpela enimel bilong solwara ol i kolim weil. Weil ya i nogat strong bilong swim na solwara karim i kam sua long bris.

Wanpela man long Kavieng i tok dispela bikpela weil i olsem wanpela lilimbur man bilong kol ples i kam long lukim ol manmeri bilong Nu Ailan provins.

Longpela bilong dispela weil em klostu long 30 mita. Planti studen i bin kamap tu long lukim dispela weil. Na planti bilong ol i tok dispela em i

namba wan taim bilong ol long lukim dispela kain bikpela enimel bilong solwara.

Wantok i kisim wanpela ripot olsem weil ya i dai long Fraide Septemba 18. Na long Trinde Septemba 23, bodi bilong em i drip i go ausait long biksolwara.

Long Tunde, sampela paiaman na fiseris opisa i go ausait long solwara wantaim wel na ol taia long traim kukim dispela weil. Tasol hatwok bilong ol i go lus nating. Na long wiken sampela man long ol ples i go katim na kisim sampela ol tit bilong dispela weil.

# Ol nesanel dokta bai protes long Nonga haus sik i mas kam aninit long nesanel gavman

OLGETA dokta bilong Nonga haus sik long Rabaul husat i memba wantaim Nesanel Dokta Asosiesen bilong PNG i askim gavman long bekim tupela askim bilong ol bipo long 4 klok apinun long Trinde Septemba 23. Sapos nogat bai ol i stap wok i go inap gutpela bekim i kamap.

Namba wan askim em long Nonga haus sik i mas kam aninit long lukaut bilong nesanel gavman. Bikos Is Nu Briten provinsal gavman i nogat inap mani long

ranim gut haus sik. Namba tu em askim em long senisim Provinsal Medikel Suprintenden bilong Nonga haus sik, Dokta Tavio Nathaniel.

Presiden bilong Nesanel Dokta Asosiesen long Mosbi, Dokta Noel Yaubih i tok ol dokta long Nonga haus sik i no straik olsem ripot i tok bipo. Ol i stap wok tasol long dispela tupela hevi. Olsem na ol i bin stap wok long Tunde Septemba 22, na kibung long dispela.

Olgeta de moa long 16 nesanel dokta long Nonga haus sik i save kibung long mekim ripot bilong ol. Olgeta ripot i go pinis long hetkwata bilong helt dipatmen long Mosbi.

Long Trinde Septemba 23, nesanel Minista bilong Helt, Francis Koimanrea wantaim seketeri bilong em i givim olgeta dispela 300 pes ripot i go long Praim Minista Paias Wingti.

Mista Wingti i tok gavman bai lukluk pas-

taim long ripot. Na bihain bai kamap long sampela tokorait.

Dokta Yaubih i tok Praim Minista Wingti wantaim ol het bilong dipatmen i mas glasim gut dispela ripot. Na givim wanpela gutpela bekim.

Presiden bilong ol nesanel dokta long Niugini Ailan, Dokta Joe Kaven i tok em i laikim olsem sampela gutpela ansa i mas kam long opis bilong em bipo long 4 klok apinun long Trinde.



**WANTOK**

NIUSPEPA BILONG OL PAPUA NIUGINI STREET

**NAEA noken semim em yet**

Olsem jenerel seketeri bilong NAEA Kapai Aria i tok, 48 aua straik i no kamap nau long apim pe bilong 15 pesen. Straik nau em long Air Niugini menesmen long kisim bek 78 NAEA memba em i bin pinisim long wok long Mande.

Menesmen i no inap long pinisim ol wokman nating, em mas i gat gupela as. Dispela 78 wokman i sakim tok long go bek wok.

Menesmen i luksave pinis long namba wan askim na kibung wantaim leba dipatmen, na Sivel Aviesen long stretim. Na ol i askim gen ol wokman long go bek wok.

I gupela tu long tingim famili pastaim. Bikhet pasin tasol i mekim na nau 78 famili bai kisim mani na baim kaikai we. I tru olsem dispela em wanpela as na NAEA i pait long apim pe. Tasol olgeta samting i gat mak bilong em.

Yu no inap long kisim wanpela bekim hariap. Em i gupela long go bek wok na wetim ansa bilong kibung. Na bihain kisim narapela stret-pela rot long painim gupela bekim.

I tru NAEA i tingim 78 memba na i laik straik gen wantaim tingting olsem menesmen mas kisim ol bek long wok. Tasol i no gupela long sapatim ol wokman husat i no bihainim askim bilong asosiesen, na i no go bek wok. Bikos dispela i bagarapim tasol nem bilong asosiesen, na tu kraik bilong namba wan askim long apim pe.

PNG i gat wanpela nesanel ea lain tasol. Olsem na NAEA i mas tingim tu wanem kain mekimsave pablik na ol bisnis bai bungim, bikos em yet i no glasim gut hevi.

**PNG bai baim kompensesen long Solomon Ailan**

PAPUA Niugini gavman bai baim kompensesen i go long ol famili bilong man bilong Solomon Ailan em ol PNG soldia i kilim long Septemba 12.

Na ol lain soldia husat i bin wokim dispela bai kisim taim. Praim Minista Paias Wingti i bin mekim dispela tok bihain long em i tok tok wantaim Solomon Ailan Praim Minista, Solomon Mamaloni

long wiken. Dispela i kamap bihain long kabinet i bung na toktok long dispela hevi. Ol i tok olsem hevi namel long tupela kantri ya i bikpela samting na gavman i mas luksave long dispela protes leta i kam long Solomon Ailan.

Insait long dispela bungtok namel long tupela praime minista, tupela i bin wanbel long wok hat long

kamapim gupela sindaun na wokbung. Dispela i bihainim tasol agrimen em ol i bin sainim long Vanuatu long mun Julai.

"Long sait bilong mi, mi baiwok bung wantaim wanwok bilong mi long Solomon Ailan long sindaun gut na lukluk long ol hevi i kamap namel long tupela kantri. Na traim long painim sampela rot long stretim ol hevi ya," Wingti i tok.

Long Septemba 12, ol PNG soldia long Bogenvil i bin kalapim boda na go insait long Solomon Ailan na kilim wanpela man na meri na kalabusim narapela. Bihain, Solomon Ailan gavman i salim wanpela protes leta i kam long PNG long Septemba 15.

Insait long dispela leta, ol i laikim olsem PNG gavman i mas baim K1 milien kompensesen na lukautim

gut dispela man ol soldia i bin holim. Leta tu i tok olsem PNG gavman i mas tok sori long dispela pasin ol soldia i mekim.

Solomon Ailan gavman i tok tu olsem ol bai raitim wanpela leta na kisim i go long kibung bilong olgeta kantri long Yuaitet Nesens na askim UN long salim wanpela kantri i kam na wok namel long tupela kantri long stretim dispela hevi.

PNG gavman tu bai salim siaman bilong Foren Afeas long palamen, Francis Saemala i go long Yuaitet Nesens Sekyuriti Kaunsil long givim ripot long dispela trabel. Foren Afeas minista John Kaputin na wanwok bilong em long Solomon Ailan, Job Duddleley bai go long dispela kibung. Long dispela taim, ol bai bung na toktok long stretim dispela hevi.

Wingti i tok gavman bilong em bai bekim dispela leta na mekim ol samting Solomon gavman i bin askim long en.

**Moa man i dai long Bogenvil**

i kam long pes 1. Septemba 10, em i tok ol ripot i soim olsem i no gat man i stap kalabus long Taurato Ailan. Na namba tu tok long dispela pas i tok ol soldia i bin kisim ol man long wanpela kanu long Ogas 29 long saut Bogenvil na sutim ol.

Em i tok sapos dispela ol man i no stap long narapela hap, ating ol soldia i kilim tupela pinis.

Bruder Desmond i tok dispela tingting bilong em i kamap bihainim ol namba wan ripot em i kisim long wokabaut bilong tupela man ya. Na tu i gat ripot bilong narapela man, Richard Kikira.

Olsem na ol bruder i laikim bai i mas gat wanpela wok painimaut i kamap bilong sekap long indai bilong dispela tupela man.

Ol arapela ripot i tok ol wokman bilong misin i save go long Solomon Ailan long kisim ol marasin na klos samting. Bikos i save nogat long Arawa na lain long hap i save painim hat tru long kisim long Rabaul na Buka.

Bruder Desmond i bin salim ol wankain pas i go tu long Praim Minista Paias Wingti, namba tu bilong em Sir Julius Chan, minista bilong Bogenvil, Michael Ogio, Difens minista Paul Tohian.

**Lae plawa gaden lus pinis long bikbus**

**SAPE METTA i raitim**

WANPELA gupela plawa gaden insait long Papua Niugini we planti pipel i save laikim tru i save stap long Lae.

Long 1960 na 1970, Lae Botanikel Gaden i save gat ol gupela, naispela, na kain kain plawa na diwai bilong bikbus. I gat ol liklik raunwara em i pulap tru long ol kain kain pis. Na namel long botanikel gaden i gat wanpela ples bilong lukautim ol pisin na ol narapela enimel. Ol i save kolim dis-

pela olsem wanpela senjueri.

Tasol nau Lae Botanikel Gaden i no moa luk olsem wanpela gaden plawa. Em i olsem wanpela hap bus bilong ol man long go na painim abus. I no gat moa ol dispela gupela na kain kain plawa, pis, pisin na ol narapela enimel. Nogat tru.

Bilong wanem na dispela ol samting i no moa stap long dispela botanikel gaden? Bekim bilong dispela em i olsem: Ol man husat i save lukautim dispela botanikel gaden i no stap moa. Olsem na ol kain kain gras na diwai nogut i bagarapim tru dispela naispela na gupela gaden bilong man, ol diwai, ol enimel bilong graun na wara na planti arapela samting.

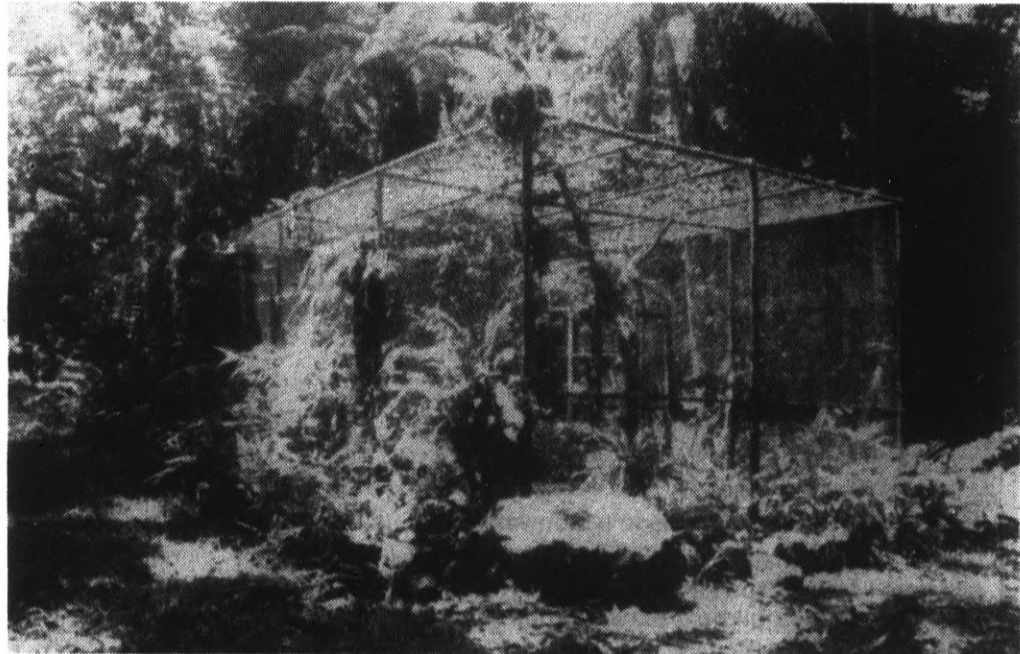

• Haus bilong lukautim ol pisin insait long Lae plawa gaden. Tasol nau ol kain kain bus na rop bilong bus i go antap. Em i bagarap olgeta.

**Gavman bai mekim save long ol PNG soldia**

PRAIM Minista Paias Wingti i tokaut olsem gavman bai mekim save long ol soldia husat i bin kilim tupela man Solomon Ailan na holim narapela.

Gavman i painimaut pinis olsem 10-pela soldia i bin mekim dispela trabel.

Long las wik Fonde, Septemba 17, kabinet odaim eking Komanda bilong PNG Difens Fos, Kenol Bob Dademo long rausim komanda bilong ol smol Bot Tim na ol soldia bilong em long Bogenvil na salim ol i go bek long kem bilong ol.

Na em i givim wanpela strongpela tok lukaut long ol soldia long pinis long brukim boda na go insait long Solomon Ailan. Gavman i bin tok amamas tu long Solomon Ailan gavman long tambuim ol BRA long go hait long hap.

Wingti i tok, "Dispela i gupela bikos em bai helpim mipela long daunim kwik dispela hevi bilong Bogenvil. Mipela i gat wankain pasin tumbuna na ples bilong mipela tu i klostu klostu. Olsem na mipela i mas stretim dispela hevi long gupela we."

Em i tok dispela pasin we ol lida bilong tupela kantri i toktok wantaim i soim olsem tupela i laik stretim ol tingting nogut na kamapim gupela sindaun.

"Samting i kamap i bin kamap pinis. Tasol gavman bilong mi bai i no inap larim wankain samting gen long kamap.

**WANTOK**

NIUSPEPA BILONG OL PAPUA NIUGINI STREET

P.O. Box 1982 BOROKO  
Telepon Namba: 25 2500  
Feks Namba: 25 2579

**PE BILONG WANPELA YIA 52 NIUSPEPA**

PLES	AIR
Mosbi	K30.00
Arapela PNG eria	K60.00
Australia na Nu Silan	K92.00
Esia pasifik na Japan	K123.00
Amerika na Yurop	K180.00





# Maborasa pinis na Madang Festival stat

## MESERY GUBAG I raitim

MADANG provinsal gavman i luksave olsem kalsa i wanpela bikpela samting long provins.

Na bihainim tasol polisi bilong Wingti gavman, ol bai traim long skulim ol pipel long luksave long kalsa

bilong ol. Primia Andrew Ariako i bin mekim dispela tok taim em i tok welkam long ol pipel long kamap long Madang Festival So long Fraide, Septemba 18. Moa long 25,000

manmeri i bin kamap long dispela so. So i bin stat long Fonde, Septemba 17 i go inap long 20 Septemba. Isten Hailans primia Robert Atiyafa na Viles Sevises na Provinsal Afeas minista John

Nilkare tu i bin stap long dispela so.

Madang Festival i kamap bilong makim de provinsel gavman i bin kamap na larim ol pipel i kam bung long soim kalsa bilong ol. Em i tok as tingting bilong Madang Festival em long bungim ol pipel bai ol i ken pilim olsem ol i wanpela provins insait long kantri.

Olsem na gavman bai putim sampela mani long kirapim gen ol pasin tumbuna we i wok long dai isi isi nau.

"Mipela bai putim sampela mani long stretim dispela misium bilong provins. Dispela bai helpim ol long stretim gut dispela haus we ol samting bilong ol tumbuna i stap long en," Ariako i tok.

"Na tu long tok save long ol pipel long as we kalsa i bikpela samting na ol i mas lukautim gut na skulim ol yangpela bilong yumi.

□ Kanage wantaim tripela poroman bilong em; Saina, Briton na Abo. Fotnait na ol i go long Banana Klap long Wewak na dring bia i stap. Ol spak na mekim pani nabaut. Saina mekim pani stori nau. "Cheers to the great wall of Saina." Ol sindaun liklik na Briton kirap tokim ol, "Bois Cheers to the Queen of England." I no long taim Abo kirap na tok, "Bois Cheers to the Kangaroos of Australia that will jump over the Great wall of Saina, na bagarapim sindaun bilong Kwin bilong Ingran."

Nau taim bilong Kanage. Kanage kirap na tokim ol, "Kanage em bikpela samting ya. Yupela Cheers i stap, mi bilong Yangoru drop tasol." Bihain ol i lukim olsem no gat bia na ol i belhat na raunim Kanage.

Andii Gendii WEWAK

■ Sipi em wanpela lapun man na em i no skul long bipo. Tasol oltaim em laik tok inglis. Olsem na taim em i raun na harim ol manmeri tok inglis, em bai lokim tasol long het bilong em. Wanpela taim em sindaun i stap wantaim Kanage na pikinini bilong em i bikhet. Em tokim pikinini long stap isi tasol pikinini tanim na bikmaus long em.

Sipi belhat olgeta na singaut long tok inglis. "Hey son! Don't you off the maus to you father. I you father grow you big." Taim Kanage harim olsem em i kilim skin stret long lap.

Joe Baiwara MOSBI

□ Wanpela taim Kanage i go raun long Papuan Disko. Em wokabaut i go daun na lukim wanpela meri Buang wantaim wanpela waitman gris i stap arere long rot.

Kanage hait arere long ka bilong tupela na harim tupela i stap. I no long taim em i harim meri Buang i kapupuk strong tru. Kanage harim na em i kilim skin stret long lap. Waitman i harim na askim meri Buang, "Darling whats that sound?" Meri Buang kirap na tokim em, "Sorry Darling, Its Kapliuk." Taim Kanage harim meri Buang stallim olgeta nek na tok "kapliuk", em i killim skin stret long lap na ranawe.

Yambo Ngatu MOSBI



• Ol boi bilong Kranget string ben long Madang i skrapim gita na tok gutbai long nem Maborasa Festival na tok welkam long Madang Festival. Dispela bikpela amamas i bin kamap long Fraide, 18 Septemba long Madang. Foto: Mesery Gubag.

## Yalu tokim ol Wes Sepik long wokbung oltaim

OLGETA pipel bilong Wes Sepik i mas sanap strong na wokbung oltaim. Maski sapos ol i pablik sevan bilong ol arapela provins o Wes Sepik yet. Olgeta i mas bung na givim sapat long wok ol i mekim. Na ol sios tu i mas go het long strongim pasin kristen insait long provins na kantri.

Primia bilong Wes Sepik, Egbert Yalu i bin tokim moa long 2,000 manmeri long Peter Cole pilai graun long Vanimo long Independens De.

Em i tokim ol pipel olsem independens i min long sanap long lek bilong wan wan yet. "Na yumi wan wan i mas wok hat long lukautim yumi yet. Na givim sapat i go long wok bilong provinsal na nesanel gavman."

Long ol toktok bilong em, Primia Yalu i tok Papua Niugini i mas tenkim

Australia long givim PNG independens olsem wanpela presen nating. Na rogat blut i bin lus olsem ol arapela kantri long wol.

Primia i tok sapos gutpela wokbung i no kamap, kain kain bikpela hevi bai kamap. Wanpela piksa bilong dispela em long Bogenvil ailan.

Na long Papua Niugini, primia i givim piksa bilong gutpela wokbung olsem long ol pipel bilong Momase rijon. Bikos ol dispela lain i gat tingting bilong wokbung na sanap olsem wanpela kantri.

Tasol rijinol memba bilong Wes Sepik, John Tekwie i tok 17 yia bihain long independens na planti pipel bilong Wes Sepik i stap olsem long taim bipo. Na long ol dispela lain, independens i no gat wanpela mining long laip bilong ol.

## Kos helpim ol tisa bilong rit na rait skul

YWCA long Goroka i holim pinis wanpela woksop bilong ol tisa long skulim ol pipel long rit na rait na luksave long ol samting olsem ol graun, solwara, bus na ol samting i stap nabaut long ol.

Na dispela woksop i bin stap inap long tripela wik. Klostu long 50 pipel i bin stap insait long dispela woksop. Na ol i kam long olgeta hap long kantri. Meri husat i bin go pas long dispela woksop em Anna Maben.

Insait long dispela woksop, ol i lainim long kamapim ol sampela progrem we i ken helpim ol long ol wok ol i mekim long ol wan wan ples long ol provins. Sampela trening ol i bin kisim long dispela woksop em long we bilong kirapim ol Tok Ples Pri Skul na skul bilong ol bikpela manmeri long lainim long rit na rait.

PNG Trust i bin givim mani long holim dispela woksop.

MR BOSMAN  
BILONG STOA

I gat

FRI

PK  
Tee Shirt  
bilong  
yu!

10t  
WRIGLEY'S  
ARROWMINT  
CHEWING GUM

WRIGLEY'S  
PK  
CHEWING GUM

10t  
WRIGLEY'S  
JUICY  
FRUIT  
CHEWING GUM

hubba  
hubba  
hubba

BIG  
BOY  
CHEWING GUM

taim yu baim

5 PELA BOKIS long wanpela

long dispela prodak long

Sullivans — Mendi, Sullivans — Mt. Hagen,

Lamana — Goroka, Wabu — Bulolo

Long mun 1st - 30th Septemba tasol!

HRD 13208

## TU MINIT TINGTING

### YU LAIK KISIM WANEM PE LONG WOK BILONG YU ?

*"Ol i kisim pinis pe bilong ol." (Mt 6: 2)*

LONG Gutnius stori bilong dispela Sande (L 17: 5-10), Jisas i tok long ol wokboi i no bin kisim spesel pe. Tasol long Matyu 6: 1-8, em i wokim narapela kain stori bilong skulim ol Farise i save hambak na mekim gutpela wok long ai bilong ol pipel, bai ol i ken kisim biknem na biknam-ba.

I gat sampela Kristen i ting olsem: Kristen tru i no ken wok bilong kisim pe; em i mas mekim wok nating. Tasol dispela aida i no stret. Jisas yet i bin tok olsem, i orait tru long yumi wetim gutpela pe bai kamap long han bilong yumi sapos yumi bin mekim gut long ol arapela manmeri. Long Matyu 5: 12, em i tok bai olgeta hatwok bilong yumi i stap long buk bilong God. Na long Matyu 10:42, em i tok long pe bai kamap long man i givim kap kolwara long yu. Na long Matyu 25:14, em i stori long kain kain pe i kamap long kain kain wok bilong wokman. Long bikpela kot long las de, bai yumi wan wan i kisim pe long wok bilong yumi. Lukim Matyu 25: 31-46.

Na planti planti taim long Nupela Testamen, Jisas i promisim kingdom bilong heven long ol gutpela pipel. Olsem na yumi ken lukim: Jisas i bilip tru long bekim wok long pe.

Em i lo bilong bel bilong yumi, olgeta wan wan wok bilong yumi i save sut i go long wanpela gol. Long tingting bilong yumi, olgeta wok bilong yumi bai gat pe long en. Sampela taim pasin amamas na pasin hepi em i pe bilong wanpela gutpela wok. Sapos i no gat pe olgeta long wanpela wok, yumi no laik mekim em. Dispela em i no rong, em i lo bilong laip na skin bilong yumi.

Na narapela poin: sapos i no gat pe olgeta bilong stap gut, bilong wanem as bai mi stap gut? Sapos narapela man i mekim pasin nogut na em i kisim wankain pe olsem mi, bai dispela i no stret. Gutpela pe na pe nogut, tupela i givim mining long laip bilong yumi.

Tasol long taim yumi Kristen i

tok long pe, yumi mas lukaut long wanpela poin. Jisas i no bin promis bai yumi kisim pe long dispela graun. Em i no bin promis bai yumi winim planti mani na i sindaun gut na i stap isi tasol.

Nogat. Dispela tingting em i tingting bilong ol Juda long Olpela Testamen. Buk Job i stap insait long Olpela Testamen bilong soim olsem: sampela taim God i save larim gutpela man i painim taim nogut long dispela graun, bilong traim em.

Jisas oltaim oltaim i bin promis bai yumi kisim gutpela laip inap oltaim long heven i olsem bikpela pe bilong gutpela wok na pasin bilong yumi. Tasol ol manmeri i haiden na i no Kristen ol i no bilip olgeta long ples bilong heven na pe bilong heven. Em i save lap long dispela. Ol i bilip long dispela graun tasol, na long painim gutpela taim long dispela laip nau. Heven maski.

Tasol nogut yu ting, yumi Kris-

ten bai kisim gutpela pe long heven tasol. Nogat. Hia long graun tu yumi save kisim wanpela gutpela pe i stap insait long bel bilong yumi. Taim yumi mekim gutpela pasin o gutpela wok, bel bilong yumi i filim gut tru. Man em i no inap baim dispela filim bilong bel isi na bel hepi.

Ol i stori long wanpela man i save paitim wanpela lektrik gita long wanpela bikpela stringben. Em i wokabaut i go long prektis wantaim ol arapela memba bilong stringben. Nau em i painim wanpela ka i planim long hap rot i gat wara. Orait, em i putim gita bilong em i stap na em i go insait helpim ol man long subim ka i kam ausait na i sanap bek long strongpela graun. Ol man ya i hatwok inap longpela taim liklik, na klos bilong ol i doti nogut tru. Bihain tru, dispela gita pilaya i kamap long prektis, tasol em i tulet pinis. Ol arapela pilaya i tokim em olsem: "Sore, yu no bin harim gutpela musik ." Tasol



FRANK MIHALIC I RAITIM

em i bekim tok olsem: "No waris! Wanpela gutpela musik i krai nau tasol insait long lewa bilong mi.....na em bai krai inap long biknait."

Em i piksa bilong soim olsem wanem hia long graun pe bilong gutpela wok i stap insait long bel bilong yumi na i no ausait long en.

Bikpela pe tru i wetim gutpela wok bilong yumi wan wan Kristen em i dispela: bai yumi lukim pes bilong God yet. Bikpela gol long laip bilong yumi olgeta Kristen em i long bungim God na lukim God na stap hepi inap oltaim wantaim God long ples bilong em.

## Luteran Sios holim namba tri Wokmeri konprens long Laloki

LUTERAN Sios (ELC-PNG) i bin holim wanpela bikpela bung long Mosbi las wiken.

Dispela bung i kamap long Sande long Sir John Guise stedium bilong opim namba tri konprens bilong ol meri. Konprens i bin stat long Sande, 20 Septemba na bai pinis

long dispela wik Sande.

Ol lain bilong Papua Distrik Wimens Felosip i lukautim dispela bung bilong ol meri. Insait long dispela konprens, olgeta 13 distrik wantaim tripela nupela distrik bilong Luteran Sios i salim ol meri i kam long Mosbi.

Na i bin gat ol memba bilong het opis long Ampo, Lae tu i kamap long dispela bung. Namel long ol em het bisop bilong Luteran Sios long Papua Niugini, Bisop Getake Gam.

Long makim gavman bilong Papua Niugini long Sande em minista bilong Yut na Hom

Afeas, Andrew Posai.

Het tok bilong bung bilong ol meri long dispela yia em: "I stap gut wantaim olgeta samt- ing God i kamapim".

Pastaim long ol samt- ing i stat, ol meri deleet bilong wan wan sios distrik i sanap long grup bilong ol yet na go insait long stedi-

um. Na tupela singsing tumbuna grup i bin pulim ol i go insait. Dispela em tupela singsing tumbuna grup bilong ol lain bilong tok ples Kote na ol Siassi.

Bihain tasol long olgeta meri i go insait bung long stedium, ol lain Kote i wokim wanpela drama pilai. Dispela drama pilai bilong ol i stori long wanpela meri husat i gat bikpela sua long lek na i painim ol man bilong helpim na pasim sua bilong em. Mekim i go na wanpela meri i kamap helpim em.

Dispela drama pilai i sutim tingting bilong wok ol meri inap mekim insait long ol PNG sosaiti na komyuniti tude. Na Minista Posai i bin strongim moa dispela tingting insait long ol toktok bilong em bihain.

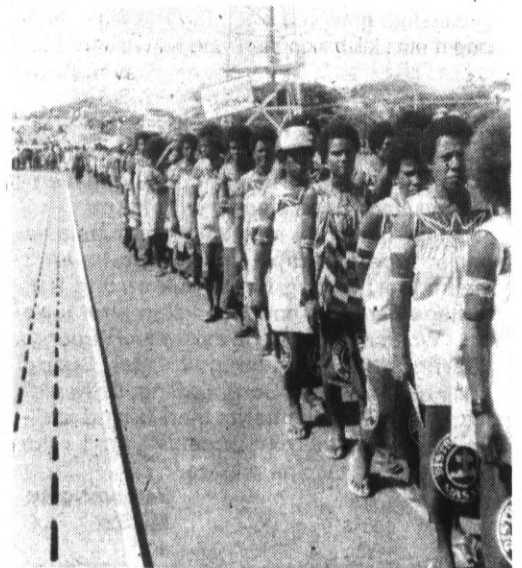

Ol meri i mas i go insait long stedium.

Taim dispela drama pilai bilong ol Kote i pinis, ol lain bilong Towamo musik ministri i skrapim gita na wokim singsing bilong ol long liptimamim nem bilong God. Dispela nau i sta-

tim lotu bilong givim tenkyu, liptimamim nem bilong Papa God na askim blesing bilong em long dispela konprens bilong ol meri.

Insait long lotu i bin gat tupela rit

## Minista amamas long wok sios ol meri i karim

WOK bilong sios na ol meri bai bringim gutpela sindaun na helpim kantri moa long wanem samt- ing gavman inap mekim.

Bikos ol sios na ol meri inap go insait tru long ol ples na ol komyuniti we ol pipel i stap long en.

Minista bilong Yut na Hom Afeas, Andrew Posai i bin mekim dispela toktok long bung bilong ol meri deleet bilong 13 distrik bilong Luteran Sios long Papua Niugini long Sande. Na minista i mekim ol dispela toktok long Sir John Guise stedium long Mosbi taim em i kisim ples bilong deputi praim minista na minista i bosim wok bilong mani, Sir

Julius Chan.

Sir Julius i no inap kamap bungim ol bikpela lain memba bilong Luteran Sios long Sande bikos em i stap long Amerika long wanpela kibung.

Minista Posai i tok wok bilong ol meri i no liklik. Ol i gat bikpela wok tru long autim Tok bilong God insait long famili na komyuniti. Tasol i no em tasol, dispela inap kamap tu long ol rot ol i bihainim, pasin na bilip bilong ol.

Em i tokim ol olsem ol namba wan lain misineri i bin luksave olsem ol meri tu inap mekim wok long i go moa long pes 7



Ol meri Siassi i bilas na bringim ol deleet meri bilong wan wan sios distrik i go insait long ples bung long Sir John Guise stedium long Mosbi las wiken. Ol foto: Francis Ulihu.



Ol meri deleet i sanap long ol distrik grup bilong ol na harim toktok bilong ol bosmeri bilong ol.

# Is Sepik no amamasim Indipendens De

# PLIS RIPOT



**GODFRIED NIAKA | raitim**

DIPATMEN bilong Is Sepik i no bin kamapim wanpela samting bilong amamasim Indipendens De long las wik.

Ol komyuniti, pipel na famili i wokim ol samting bilong ol yet long amamasim dispela bikpela de long kantri. No gat wanpela bikpela

samting i bin kamap long provins yet.

Seketeri long Dipatmen bilong Is Sepik, Vincent Maragau i tok bikpela hevi bilong lo na oda i bin pasim ol long wokim wanpela bikpela samting long

Wewak, biktaun bilong Is Sepik.

Maragau i tok long bipo yet i kam inap nau, ol i luksave olsem long ol kain bikpela de olsem, planti bikhet pasin i save kamap. Olsem na ol pipel i

kamapim ol amamasim long bilong ol yet.

Long Turubu, Boikin na Dagua, ol kain kain pilai i bin kamap long Indipendens De. Olgeta pipel bilong Dagua i bung long ples Guminim na pilai volibal na soka long winim Bernard Narokobi sil. Ol lain bilong Boikin i bung long Hawain na pilai gen long winim narapela Bernard Narokobi sil. Na wankain tu long ol pipel bilong Turubu insait long is kos bilong Wewak. Ol i bung long ples Balik na salens long winim namba tri Bernard Narokobi sil.

Maragau i tok memba bilong Wewak long oposisen, Bernard Narokobi i bin baim na salim ol dispela sil i go long ol pipel bilong ol dispela hap long pilai na winim long amamasim Indipendens De bilong ol.

**MOSBI:** Wanpela man i bin kamap long Boroko Distrik Kot long sas bilong paulim moa long K14,800. Kot i harim olsem Worri Magari kris-mas bilong em 47 bilong ples Domara i bin mekim dispela trabel namel long 1991 na Epril long dispela yia taim em i wok olsem menesa bilong Niugini Motors long Mosbi. Ol i surikim kot bilong em i go long Oktoba 9.

**IS NU BRITEN:** Wanpela stil pasin i bin kamap long ples Ghanai long Kokopo. Plis i tok 5-pela man wantaim ol gan na busnaip i bin go long wanpela haus na hensapim wanpela famili. Taim ol lain bilong dispela famili i harim ol nois nabaut, ol i go long sekap na lukim ol raskol ya. Olsem na ol i ronim ol na sutim wanpela long spia. Plis i painimaut yet long dispela.

**MOSBI:** Ol raskol i bin stilim wanpela plis ka long las wik Fraide long Gerehu namba 3. Foapela man i karim wanpela gan i go hensapim draiva na kisim ka na ranawe. Long wankain taim yet, wanpela meri long 6 mail i bin kisim bagarap taim sampela yangpela man i pulim em i kam ausait long ka bilong em na draivim i go. Dispela trabel i kamap taim em i les long givim ki bilong ka bilong em.



*Moro felt senta...Ok Tedi maining kampani i lukim olsem ol pipel bilong Moro i no gat wanpela klinik i stap klostu. Olsem na long dispela yia, ol i opim wanpela felt senta long hap. Foto: Rudolf Ayu.*

## Primia winim vot i nogat bilip long Morobe

bilip long primia na gavman bilong em.

Bihainim te tasol, wanpela memba i bin putim nem bilong em long muvim dispela vot i nogat bilip na 10-pela memba i sainim nem bilong ol long sapotim

dispela mosen. Tasol long wankain taim, tripela memba long oposisen i lusim ol na joinim gavman.

Dispela ol tripela man ya em Steven Fukao, Tom Ikuaka Kali na Job Talau. Na primia i

bin makim ol long kamap olsem minista long gavman bilong em.

Taim oposisen i harim olsem ol tripela i lusim ol na go joinim gavman, ol i sutim tok olsem Primia Christian

wantaim ol lain bilong em i bin stilim ol tripela man ya.

Na long las wik tasol, ol tripela man ya i bin raitim wanpela leta i go long oposisen lida long givim sans long primia long mekim wok long provins. Na maski long dispela pasin long pait long kisim biknem nabaut. Bikos planti wok bilong provins i stap yet.

TITI Christian i primia bilong Morobe provins yet bihain long em i winim wanpela vot i nogat bilip, 15-14 long Tunde, Septemba 22.

Long Tunde moning taim Tutumang i bung, ol i bin gat wanpela samting tasol long agenda - vot i nogat bilip long primia na gavman bilong em.

## Skul bilong rit na rait kamap bikpela

SKUL bilong ol bikpela manmeri long rit na rait long Goroka YWCA i wok long gro yet.

Skul ya i bin stat long 1988 na i kam inap nau, 500 pipel i pinisim skul bilong ol long hap. Na nau bikos planti pipel i laik lainim long rit na rait long Tok Pisin na Inglis, YWCA i bin wokim ol klasrum i go bikpela.

Dispela skul bilong 'Lainim long Rait na Rit' i bin stat aninit long han bilong wanpela volentia tisa bilong Australia, Debbie Chapman long 1988. Long dispela taim, em i bin kisim ol mama long ol ples na skulim ol. Tasol nau planti moa lain i laikim

dispela program na em i wok long gro i go bikpela.

Olsem na YWCA i bin go askim ol oganaisesen nabaut long helpim ol long skurim dispela klasrum nau ol i gat long en. Na tupela kantri i givim helpim bilong ol. Dispela em Keneda na Australia.

Na nau ol i wokim pinis wanpela nupela klasrum bilong skul. Kodineta bilong YWCA skul bilong ol bikpela manmeri long rit na rait em Anna Maben. Em i bin kisim trening bilong em long Debbie Chapman na nau em i go pas long dispela program.

## Minista amamas long ol meri karim wok sios

i kam long pes 6

autim Tok bilong God. Na long dispela wok bilong ol, ol meri inap bringim gutpela sindaun i kam insait long ol kommyuniti na ples.

Minista i tok ELC-PNG em i wanpela bikpela sios. Na em i amamas tru long lukim olsem Sios i luksave na strongim ol meri long kisim dispela wok na bringim i go long ol pipel.

"Mi amamas olsem Sios i luksave olsem ol meri inap mekim dispela wok. Bikos long sait bilong mi, gavman yet bai i no inap mekim olsem," Mista Posai i tok.

Long ol kain kain senis nau i kamap, minista i askim tu ol meri long no ken tingting long ples tasol. Em i laikim ol meri long givim helpim na kamapim sampela gutpela tingting bilong ol wok kamap long kantri.

Na em i askim tu olsem long dispela Wokmeri konpresen program i bihainim tingting bilong luksave long ol kain kain senis, sik na pasin nau i kamap long Papua Niugini.

Bihainim dispela rot na wok ol meri ELC-PNG i mekim nau, Mista Posai i askim ol long wokbung wantaim ol lain bilong PNG Kaunsil ov Wimen. Na lus tingting long dispela liklik hevi em ol i gat wantaim kaunsil bipo.

Em i tok dipatmen bilong em i lukluk nau na i laik stretim dispela hevi bilong ol.

Long pinisim ol toktok bilong em, Minista bilong Yut na Hom Afeas i tokim ol meri "long sanap strong long wok we i bringim gutpela sindaun long ol famili na kantri".

Na em i tok dispela em i namba wan grup bilong ol sios wokmeri insait long kantri long kamapim kain samting olsem.

Long bekim ol toktok bilong minista, wanpela mausmeri bilong ol Wokmeri bilong ELC-PNG, Ruby Zeriga i tok namba wan bikpela samting insait long Papua Niugini tude em man, meri na pikinini.

Long dispela as Misis Zeriga i tok, "Dispela em i namba wan taim bilong mipela long askim yu na gavman long lukluk long ol rot bilong helpim dispela grup olsem bai mipela inap helpim ol pipel long ples.

"Mipela i laik askim yu olsem minista na gavman long lukluk long ol rot nau i stap pinis na helpim. Na i no long askim yu long mani."

Misis Zeriga i tok ol meri bai amamas tru sapos gavman inap wok olsem stia na tingting bilong ol. "Na long ol wok, mipela yet inap karim," em i tok.

Long dispela taim, mausmeri ya i bin askim tu gavman long luksave long ol wok na projek bilong sios nau i stap long ol ples. Na long wokbung wantaim sios stat long ol pipel i go long kongrisesen na i go antap olgeta.

# LAE'S NO.1 USED CARS

PNG MOTORS  
"NO. 1 CAR OF THE WEEK"

## Toyota Landcruiser

Diesel Station Wagon, Air Conditioned-Good REG.

Well Cared for **K13,950.00**

## USED CARS AT BARGAIN PRICES

NEXT WEEK SALES

**Suzuki Sierra 4x4**  
Hard tops, Choice of 2 From **K4,990.00**

**Mitsubishi L200 4x4**  
Coffee Body, Diesel Utility - Great Value **K8,990.00**

**Nissan Patrol Coffee Body** **K10,990.00**

**Isuzu NPR**  
Coffee Body, Very Clean, Price..... **K11,990.00**

**Mitsubishi L200**  
2WD, Petrol Utility **K5,490.00**



# PNG MOTORS

This weeks special apply to PNG MOTORS-LAE only

MS/PNGM



• Ol soldia i sanapim ol sel haus long Homstead, Florida. Dispela ol haus sel i bilong ol manmeri em bikpela raun win i bin kamap na bagarapim haus slip bilong ol. Moa long 85,000 haus olgeta i bin bagarap long birua ya, em i bin kamap long pinis bilong mun Oktoba.



• Ol meri bilong Irak i kism wara long raun wara na karim i go bek long haus bilong kuk kikai, na tu long waswas. Dispela em long Fonde Septemba 3. Raun wara i stap 450 kilomita longwe long biktaun bilong Irak, Bagdad.



• Siaman bilong Palestinian Liberesen Ogenaisesen (PLO) Yasser Arafat i holim pasim lida bilong Kambodia, Prins Norodom Sihanouk long Fonde Septemba 2. Dispela em long bikpela kibung bilong ol Nonalain Muvmen long Indonesia.



• Sampela bilong 14,000 soldia i glivim kalkal long ol refuji bilong Florida Siti, saut wes bilong Miami long Amerika. Bikpela win i kam long hap na bagarapim haus slip bilong planti tausen manmeri.

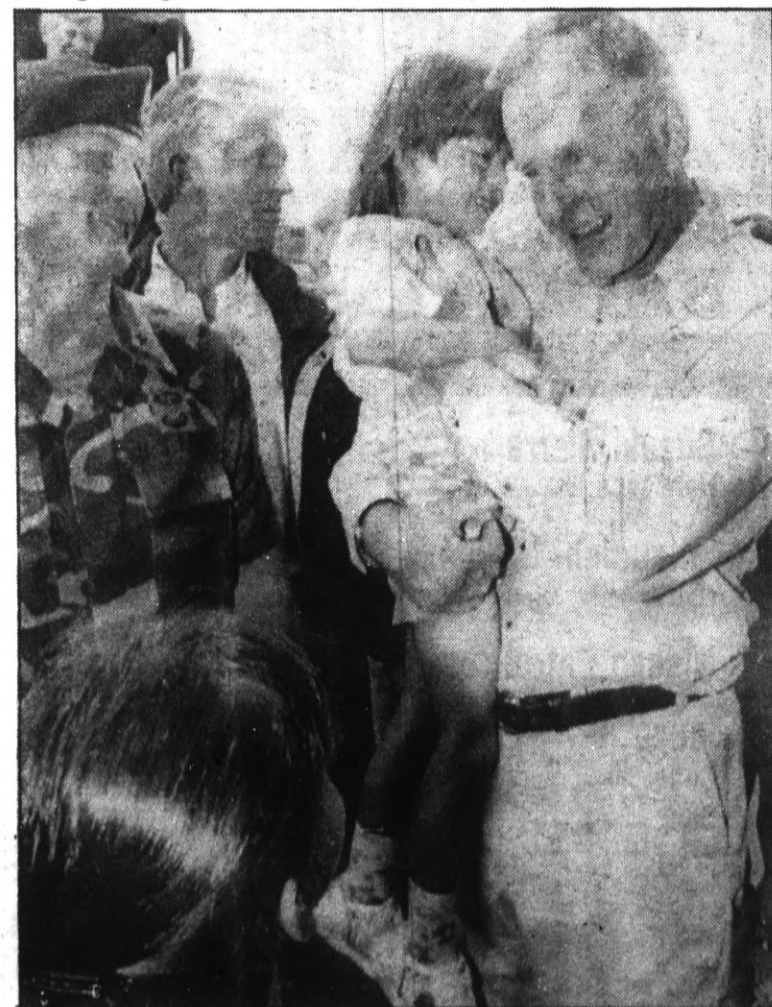

• Presiden George Bush i karim wampela pikinini meri talm em i go lukluk raun long ol birua, em i bin kamap long Florida, Amerika long pinis bilong mun Oktoba. Bikpela raun win i kamap long hap na bagarapim 85,000 haus.



• Ol refuji long Uen, westen Somalla long Afrika i kalkal long wampela kea senta. San i stap longpela talm long dispela hap bilong kantri na ples i drai nogut tru. Mekim na ol manmeri na pikinini i dai tru tru long wara na kalkal. Plant i lusim pinis skin na kamap bun nating olgeta. Ol i kism helpim i kam nau long olgeta hap bilong wol.



# **POWER**

## *to the people!*

**IT'S THE GREAT RICE REVOLUTION  
IN YOUR STORE NOW!**





(ANTAP) • Wanpela sekyuriti long opis bilong Minista bilong Interio i sekim wanpela man long Fraide Septemba 11. Dispela i bin kamap long wanpela maket long Mosko we ol isave salim ol ol marasi, dring na smok nogut wantaim ol samting bilong palt. Ol plisman i holim pasim 26 pipel olgeta.

(LEPHAN) • Ol plisman banisim bodi bilong Eitan Mor, em ol i bin kilim long Tunde Septemba 8. Mor brukim na go insait long kilnik bilong lukautim ol longlong manmeri, na kilim indal 4-pela meri, na givim bagarap long tupela moa. Ripot i tok Mista Mor i bin longlong long bipo. Tasol plis i no save long as bilong dispela birua.



(RAITHAN) • Ol pipel long Mabalakat, klostu long Pinatubo long Filipin ailan, karim sampela samting ol i ken kisim na ranawe long Fonde Septemba 10. Dispela em bihain long malmalum graun i karamapim ples.

(LEPHAN) • Ol plisman i holim pasim Carmine Alfieri long Naples, Itali long Fraide Septemba 11. Plis tok Alfieri i bin hait long 11-pela yla olgeta.



• Ol manmeri bilong Sarajevo i sanap long lain long kisim wara long Fraide Septemba 11. Dispela em long wanpela hap we bikpela palt i kamap egens ol rebel paltman bilong Sebia long biktaun bilong Bosnia. I nogat inap pawa sapial tu.



• Ol meri long Royal Ea Fos Sentrel Ben i trening long Fraide Septemba 11. Dispela em long Senisim ol Gad long Sarere long Bakingham Pales long Londoñ. Nainpela musik meri i pilal long dispela bung long Sarere, na dispela em i namba wan taim bilong ol meri long stap insait long dispela bung, bihain long 155 yla olgeta. Ripot i tok Kwin Elizabeth II i amamas tru long dispela.

# SALEM

GOVERNMENT WARNING  
SMOKING IS DANGEROUS TO HEALTH

## Ating Madang no gat saveman

Dia Edita,

Mi bilong Madang tasol nau mi stap long Tabubil long Westen provins. Mi laik autim wari bilong mi i go long ol pipel bilong Madang.

Mi no amamas long lukim ol man bilong arapela kantri na provins i makim mipela long nesenen palamen.

Bikpela kros bilong mi i go long yupela ol asples man. Bilong wanem na yupela i votim ol waitman na ol man bilong arapela provins. Olsem wanem, mipela ol asples i no gat saveman i stap o olsem wanem?

Madang i gat planti ol gutpela lida tasol yupela ol pipel i longlong na votim ol arapela man. Olsem na long arapela 5-pela yia, yumi bai stap long lukaut bilong ol man bilong arapela kantri na provins.

Sapos ol dispela lida i no bringim wok developmen, no ken kros long ol. Bikos asua i no stap long ol, bikpela rong i stap long yupela yet.

Mi laikim yumi senisim tingting long 1997 na votim ol asples man tasol. No ken harim gris bilong ol man bilong ol arapela hap.

Peter Malbro,  
WESTEN PROVINS.

## Painim maket tru ya

Dia Edita,

Mi laik toktok long sampela samting em i no stret long ai bilong mi.

Taim mi raun long Lae siti, mi lukim planti pipia na spet bilong buai. Bikpela tru em long Lae taun bas stop. Dispela hap i luk olsem wangepela ples bilong tromoi ol pipia.

Dispela bas stop i save gat planti pipia na spet bilong buai bikos sampela lain i salim buai na ol lus sigaret long hap. Dispela ol lain husat i save salim buai long bas stop em ol hailans.

Mi askim yupela long go long maket na salim buai na lus sigaret bilong yupela. Na maski long maket nabaut long publik ples. Traim na yusim het bilong yupela na mekim samting.

Ring Hauty,  
LAE.

## Mendi no gat ol publik toilet

Dia Edita

Mi laik komplem long ol provinsal memba bilong Mendi na Mendi taun kaunsil.

Mi lukim olsem Mendi taun i no gat publik toilet. Ol narapela taun long kantri i gat ol publik toilet. Olsem wanem na Mendi taun i no gat wangepela publik toilet?

Bikos long dispela, planti ol manmeri i save yusim ol liklik hap bus insait long taun olsem ples bilong pispis na pekpek.

Olsem na mi askim nau ol provinsal memba na tu taun kaunsil long lukluk long dispela samting na traime stretim dispela hevi insait long taun.

Jay Nepo Aika,  
MENDI.

## Lukautim gut ol ples pilai long ol longlong man

Dia Edita,

Mi wangepela grasrut marki Tolai. Mi laik autim liklik wari bilong mi i go long ol sekyuriti bilong spot.

Mi bin baim *Times Niuspepa* na lukim olsem wangepela ripota, nem bilong em Barbara Tomi, klostu i kisim

bikpela bagarap long taim bilong gren fainal namel long Mosbi Vipers na Hagen Eagles.

Wangepela spakman i bin bel hat na paitim em nating. Dispela i no gutpela pasin. Dispela ripota i go long kisim nius na kain longlong man olsem i no gat rait long paitim

tarangu meri ya.

Mi gat bikpela bel hevi long ol sekyuriti. Bikos ol i no save mekim gut wok bilong ol long sekim ol man. Mi askim ol long rausim botol, ston na stik long ples bilong pilai pas-taim long gem i stat. Na mi askim ol sekyuriti long sekim olgeta man husat i go insait

long lukim pilai.

Planti taim yumi save lukim ol man i pait long fil. Na dispela i save stapim planti meri na pikinini long go lukim pilai. Yumi mas senisim dispela ol rabis pasin na kamap gutpela spot manmeri.

Ngalamt Levi,  
RABAUL.

## Sapotim Viles Sevis program

Dia Edita,

Mi laik olsem nau mipela olgeta i mas sapotim gavman bilong Praim Minista Paias Wingti na deputi bilong em Sir Julius Chan.

Bikos long dispela Viles Sevis program bilong ol we ol i laik kamapim long neks yia. Mi amamas tru long dispela. Bikos program ya i sapotim tru yumi ol grasrut pipel long ples long ol kain liklik bisnis wok.

Na tuem bai holim bek ol yangpela pipel bilong yumi long stap long ples. Na bai ol i no inap go long taun long painim wok o joinim raskol.

Long tingting bilong mi, ating gavman mas rausim provinsal gavman tu. Bikos ol i save paulim mani tumas. Olsem na wok i no save kamap long ol ples.

Thomas Karme  
KIMBE

## God papa yet makim ol lida

Dia Edita,

Mi laik toktok long ol olupela memba husat i bin lus long 1992 nesenen ileksen.

Em i gutpela, bikos ol i no save bringim sevis i go long ol pipel husat i votim ol. Na yupela ol pipel i no ken sapotim ol memba husat i lus.

Bikos ol i no gutpela lida. God yet i makim ol lida pinis. Na nau yumi mas lukluk long ol nupela memba ya. Bai ol i wok gut insait long dispela 5-pela yia o no gat?

Sapos ol i no wok gut, God bai mekim nupela lida-bihain long 1997.

Sapos yumi no amamas long ol lida nau na mekim nabaut, bai yumi bagarapim sindaun bilong yumi yet. Ol man husat i winim ol sia nau i no bilong ol arapela kantri. Nogat, em yumi Papua Niugini yet.

## Bikpela bung bilong lotu mas kamap long Morobe

Dia Edita,

Mi bilong Morobe provins na mi bin raun

pinis long sampela arapela provins. Na mi save lukim

olsem ol i save holim ol bikpela bung bilong lotu. Na planti raskol

manki na pipel i save tanim bel. Na sindaun bilong ol i kamap gut

pela tru, na ol i no save mekim trabel moa.



Tasol hia long Morobe, nogat wangepela kain miting i save kamap. Planti yangpela na lapun manmeri i nogat pasin bilong laikim ol arapela i stap wantaim ol. Nogat tru.

Olsem na gavman i mas lukluk long dispela.

Ol mas oraitim bung bilong ol lotu long kamap long wanwan distrik bilong provins. Na ol pipel i mas tanim bel na kisim Jisas long laip bilong ol. Em tasol.

Dian Jonah  
BULOLO

Gabriel Popna  
HAGEN

## Ol asples Rabaul i stap we Rispektim ol lotu singsing long PGS

Dia Edita

Mi laik autim liklik wari bilong mi long ol papa bilong ol stua insait long Rabaul taun.

Olgeta taim mi save go insait long ol stua na mi painim o lukim olsem ol manmeri husat i wok insait long ol stua i no bilong asples Rabaul.

Dispela pasin i no gutpela tumas. Mipela ol asples stret i no wok long taun bilong mipela. Ol manmeri bilong ol narapela hap i pulapim

nating taun bilong mipela.

Ating sapos mipela ol asples yet i wok long taun, bai i no gat ol bikpela trabel i kamap. Ol bikhet pasin i kamap long taun long wanem i gat ol kain kain manmeri bilong ol narapela hap i pulap i stap.

Em tasol liklik bel hevi bilong mi. Husat i laik sapotim o egensim i ken rait i go long *Wantok Niuspepa*.  
Therry,  
RABAUL.

Dia Edita,

Mi laik komplem long ol lain husat i save wokim ol kaset long Pasifik Gol Studio.

Ol i save putim ol musik bilong danis long fran bilong ol kaset bilong ol lotu singsing. Inap yupela ol dispela

lain i stapim dispela kain pasin na larim wangepela kain singsing tasol i stap long kaset?

Ol song bilong lotu em bilong lotu. Na ol

song bilong danis em bilong danis. No ken miksim nabaut.

Pitz Yuty,  
KIMBE.

## Raitim tu ol NPF fom long Motu na Tok Pisin

Dia Edita,

Wari bilong mi em i olsem. Inap ol NPF lain i raitim ol aplikesen fom bilong ol long Motu na Tok Pisin tu?

Mi askim bikos mipela sampela man i no save long tok Inglis. Na mipela i save painim

hat long pulimapi fom bilong ol. Sampela ol wokman i lapun olsem na ol i save askim ol narapela man long helpim ol na pulimapi ol fom ya. Em tasol na tenkyu tru.

Joé Hillary,  
BOROKO.

## No ken kolim moa nem Yambang

Dia Edita,

Mi no amamas long ol pipel bilong Austrolabe Be i kolim mipela ol busman bilong Madang, *Yambang*.

Dispela toktok i mekim bel bilong mi hat olsem na mi laik autim long *Wantok Niuspepa* na ol i mas stapim dispela toktok.

Mi laik tok save olsem long bipo, mipela i save pret long solwara na tu long kaikai sol na swim long nambis.

Tasol nau, mipela i save pinis long olgeta samting ya. Na mi no laik long ol dispela pipel i kolim mipela *Yambang*.

Ol pipel bilong Austrolabe Be i mas save olsem, bipo ol tumbuna bilong ol tu i save pret long sampela samt-

ing bilong bus. Na ol i kolim dispela nem i olsem ol i paitim mipela long pes.

Yupela i mas save olsem sampela samting bilong ol waitman yupela i no save yet. Olsem wanem, yupela ting yupela supamen? Mi tokim yupela stret olsem, yumi olgeta i wankain tasol. Ples tasol i mekim na yupela kolim mipela *Yambang*.

Tasol yupela tu *Yambang* bikos sampela bilong yupela i no save long rit na rait. Olsem na mi laik askim yupela long stapim dispela toktok *Yambang* na yumi olgeta i mas stap amamas wantaim olsem ol brata na susa.

Eggonwah,  
MADANG.

Husat i laik salim pas i kam long edita i mas raitim stret nem na adres bilong yu. Na salim i kam long dispela adres: Edita, Wantok Niuspepa, P. O. Box 1982, BOROKO, N.C.D.

# YU NO INAP WINIM TOYOTA HILUX

Dispela kar tasol em i bikpela na strongpela 1 tonne 4 wil draiv kar insait long Papua Niugini nau. Toyota Hilux i givim yu nambawan 2800cc disil pawa na i gat 5 pela gia, nambawan ples bilong sindaun bilong 5 pela man. Na i gat ol arapela samting olsem ol TJM Bulba, em bilong pasim ol mekim wanpela samting sapos yu no gat dispela Toyota Hilux 4WD. Bikpela spea pat na sevis divisen bilong Ela Motors long olgeta hap bilong Papua Niugini i sapotim dispela nupela kar.

## Ela Motors

NAMBAWAN LONG  
PAPUA NIUGINI

PORT MORESBY 229400  
LAE 433655  
RABAUL 921988  
MADANG 822188  
GOROKA 721844  
MT HAGEN 521888  
WEWAK 862255  
KAVIENG 942132  
KIMBE 935155  
TABUBIL 589060  
VANIMO 871254  
PORGERA 579367



## Mekim haus bilong ol marit soldia

**Dia Edita,**  
Mi laik toktok liklik long Papua Niugini Difens Fos.  
Mi laik sapotim leta bilong brata Gemsey Aika. Em bin toktok long ol marit soldia i

nogat haus long slip. Dispela hevi i bikpela tru na bagarapim sindaun bilong mipela sampela.  
Mi laikim minista na ol bikman bilong Difens Fos long stretim dispela hevi. Ol soldia bilong yumi i wok long salim skin bilong ol long wok long Bogenvil

na long ol boda provins long lukautim yumi.  
Dispela ol lain i gat gutpela edukesen. Tasol gavman i putim ol long ol haus olsem ol kanaka man stret. Dispela i no gutpela. Em tasol.

**Augustina Gireiau RABAUL**

## EMTV noken wansait tumas long ol Tolai na Papua tasol

**Dia Edita,**  
Wari bilong mi em olsem. Olgeta taim long EMTV, mi save lukim ol Papua na Tolai i kamap wantaim singsing na pasin tumbuna bilong ol.

Na ol arapela provins i nogat. Askim bilong mi em olsem; yumi gat tupela provins tasol long PNG?

Mi laikim EMTV long soim ol singsing na pasin tumbuna bilong olgeta provins long kantri.

Plis ol bos bilong EMTV, traim na mekim olgeta provins sem tasol, na tu mekim gutpela progrem. Dispela bai winim bel bilong lain bilong ol arapela kantri. Na bai ol amamas long lukim ol progrem bilong yumi long EMTV.

**Thomas Manuel KIUNGA**

## Jaks painim tupela poro

**Dia Edita,**  
Mi painim tupela pren bilong me. Bipo mipela i save rait long mipela yet tasol nau mi no save long wanem hap tupela i stap long en.

Olsem na yu husat i save long we ol i stap o sapos yutupela ritim dispela leta, plis rait i kam long mi o tokim ol long rait i kam long dispela adres:

**Joe Jaks  
Tabubil Engineering  
P.O.Box 431  
Western Province**

## Pasin bilong lusman

**Dia Edita,**  
Mi laik toktok long wanpe a pasin ol lusman i save mekim.

Em i olsem. Taim ol i gat laik long ol meri, ol i save rait na askim long prenim ol. Tasol ol i no save putim nem stret bilong ol long pas.

Dispela em pasin bilong ol lusman stret. Yupela pret na putim gaman nem bilong yupela.

Sapos yupela laikim meri, go stret long pes bilong ol na askim.

Noken putim gaman nem na rait. Noken ting bai mipela bekim pas bilong yupela. Lus tru.

**Frida David BIALLA**

## Tok amamas long PDM na PPP

**Dia Edita**

Mi wanpela sapota bilong PDM na PPP. Olsem na mi laik tok amamas i go long nupela praim minista Paias Wingti.

Mi gat bilip olsem planti arapela manmeri insait long kantri tu i amamas long Wingti i kamap praim minista.

ista.

Na tu mi laik tok amamas i go long nupela spika bilong palamen, Bill Skate, Memba bilong Rabaul, John Kaputin na namba tu praim minista na lida bilong PPP, Sir Julius Chan.

**Moses Komea  
Ambusa Plantasin BIALLA**

## Ol Madang i aipas na votim ol ausait pipel

**Dia Edita**

Mi laik sapotim pas bilong Albert Ruarri em i bin kamap long *Wantok Niuspepa* long Fonde Julai 16

Mipela planti manmeri insait long Madang provins i sapotim toktok bilong Albert Ruarri. Em i toktok long tupela waitman na wanpela Hailans man husat i win long nesanel ileksen insait long Madang provins.

Mi laik tok olsem dispela tripela man i kam long Madang provins long mekim ol wok bisnis. Nem bilong ol em Peter Barter, Tim Ward na Stanley Pil.

Ating ol manmeri bilong Madang i aipas na votim ol dispela tripela man. I luk olsem long ileksen taim, i nogat wanpela asples man stret i bin resis. Olsem na dispela tripela man i sanap long ileksen na ol i win.

**Jacok Mauwi LAE**

## Ol dokta na nes long Angau mas wokhat

**Dia Edita**

Mi wanpela man blong ples Biarui insait long Morobe provins. Mi stap nau long Lae Siti.

Mi save lukim olsem ol dokta na nes bilong Angau haus sik long Lae i

no save mekim wok bilong ol gut.

Wanpela taim mi kisim susa bilong mi i go long haus sik na ol dokta na nes i no bin kam hariap na givim marasin long em. Na klostu em i kisim bikpela bagarap.

Olsem na mi laik tokim ol dokta na nes bilong Angau long lusim dispela kain pasin bilong ol.

Yupela i mas wok gut na helpim ol sikman. Sapos yupela i les long mekim wok bilong yupela na kisim nating mani long ai bilong Papa God, yupela i mekim pekato o sin.

**Kai Fonke LAE**

# Kerema nogut o?

**Dia Edita,**

Mi wanpela manki Kerema na mi laik autim wari bilong mi i go long ol olpela na nupela palamen memba bilong Galp provins.

Longpela taim nau na mi no lukim wanpela developmen i kamap long provins. Bikpela piksa em biktaun bilong Galp provins, Kerema. Taim mi liklik manki i kam inap nau mi no lukim planti senis i kamap long taun.

## Maski yusim mani long pamuk

**Dia Edita,**

Insait long Klambe mi lukim olsem taim ol man Mendi na Tari i salim wel pam na kisim mani, ol i save go raun wantaim ol pamuk meri na givim mani long ol.

Olsem na mi laik tok dispela em i no wanpela gutpela pasin tumas. Long wanem dispela i ken bagarapim sindaun bilong famili. Na tu i ken bringim kainkain sik i kam insait long famili

Mani i kam long hatwok bilong yupela. Olsem na yupela i mas yusim long stretpela rot.

**K. Sali Morowa  
Kavugara Sab Divisen  
TALASIA**

Mi laik save ol memba bilong Galp i stap we. Mipela ol pipel i makim yupela long pait hat long bringim developmen. Tasol yupela i save givim baksait stret long ol lain husat i votim yupela.

Mi laikim olgeta nupela memba bilong palamen i mas wok bung wantaim na wokim sampela samting long helpim ol pipel. Bikos nau yet planti Kerema i save

les long stap long provins na kam stap nabaut long Mosbi.

Traim na helpim ol pipel na ol i ken stap

long ples na mekim wok.

**Nelson Haero Ma'a LAE**

## Painim pren

**Nem:** Ekow Dominic  
**Krismas:** 19  
**Adres:** P.O.Box A.16  
Adisadel  
Cape Coast, Ghana.

**Save Laikim:** Pilai soka, harim musik na senisim ol presen

**Nem:** Peter Kwesi Hagan  
**Krismas:** 16  
**Adres:** Pedu J.S.S. "A"  
P.O.Box A. 97  
Adisadel  
Cape Coast, Ghana.

**Save Laikim:** Ritim buk, danis na pilai volibal.

**Nem:** Nana B. Hagan  
**Krismas:** 24  
**Adres:** Flowers Street  
P.O.Box A.16  
Adisadel  
Cape Coast, Ghana.

**Save Laikim:** Pilai volibal, harim musik, raitim leta, swim na danis.

# Ol lida tu mas kalabus aninit long wanpela lo

**Dia Edita**

Mi laik sapotim pas bilong Joseph Tongang em i bin kamap long *Wantok Niuspepa* Namba 941.

Yumi olgeta pipel bilong Papua Niugini i stap aninit long mamalo bilong yumi yet we gavman i oraitim. Na sapos yumi sakim dis-

pela mamalo bilong yumi yet bai yumi kalabus.

Tasol planti taim mi save harim long redio na ritim long niuspepa olsem taim wanpela lida o loman i mekim wanpela rong, lo bai i no inap kalabusim dispela lida o loman.

Ol bai rausim em

tasol long wok bilong em.

Na sapos wanpela grasrut i mekim wanpela rong, bai ol i givim em bikpela mekimsave na planti wik, mun na yia long kalabus.

Ating ol dispela lida na loman i olsem God o sampela kain ol speelman, na gavman i

no save kalabusim ol. Long tingting bilong mi, mi laik tok olsem yumi olgeta, maski ol grasrut, lida na tu loman i mas kisim wankain mekimsave aninit long mamalo bilong yumi yet.

**Paul Moses BULOLO**

## Baibel egens stil pasin long graun

**Dia Edita,**

Mi laik autim wari bilong mi long ol stil pasin i save kamap hia long Rabaul.

Dispela stil pasin i no gutpela long laip bilong yumi ol man. I luk olsem dispela pasin i

save kamap long planti hap bilong Papua Niugini tu.

Sapos yu husat brata i save mekim dispela pasin, yupela mas lusim na stap isi. Sapos yupela bikhet na mekim kain pasin

olsem; bai yupela sotim laip bilong yupela yet. Baibel i tok long Efesas 4:27 - 28 long ol stilman i mas lusim dispela kain pasin. Tenkyu.

**Andom Yuwis RABAUL**

## Bilong wanem na takwie rausim Sir Michael long Sandaun

**Dia Edita**

Mi laik autim belhevi bilong mi i go long nupela rijonel memba bilong Sandaun provins, John Tekwie long wanem samting em i bin mekim long Sir Michael Somare long taim bilong ileksen.

Taim Sir Michael i bin kam long Vanimo long baim nominesin fi bilong ol Pangu Pati kendidet, John i bin kisim ol sapota bilong em na ol i singaut na bikmaus i go long Somare.

Bihain long vot, Tekwie i winim Sandaun

Rijonel sia na i joinim Pipels Eksen Pati (PAP).

Olsem na mi laik tok ating Tekwie i no sem tru long go na joinim

dispela pati. Bilong wanem na yu rausim Somare long Sandaun?

**Jude K Sops VANIMO**

## Rausim ol maket arere long Rabaul nambis

**Dia Edita,**  
Mi bilong Sauten Hailans tasol nau mi stap long Rabaul.

Mi save raun long taun na lukim olsem long olgeta kona spet bual i no isi.

Na dispela i no stret long tingting bilong

mi. Mi laikim taun kaunsi long rausim ol maket arere long nambis na kisim i go long arapela hap. Em tasol wari bilong mi.

**Paul Payop RABAUL**

## Noken salim long mani

**Dia Edita,**  
Mi lukim wanpela pasin hia long Papua Niugini i no stret tru.

Planti taim mi save lukim ol meri wantok i save mekim pasin pamuk wantaim ol waitman. Ol i save mekim olsem long kisim promesen long wok o long kisim mani.

Sampela bilong ol dispela meri em ol marit meri. Na kain pasin olsem i rabis tru long ai bilong mi. Husat i save mekim kain pasin olsem, plis stapim nau.

**Fonde Marum BIALLA**



# Turis minista tokim ol Wes Sepik long holim strong pasin tumbuna

**FELIX RAMRAM i raitim**

MOA long 2,000 man, long lukim kalsarel so meri na pikinini long bilong provins long Wes Sepik i bin kamap long Indipendens De.

## Memba bilong Sentrel sapatim wok bisnis long Esia rijon

NESENEL memba bilong Sentrel provins long palamen, John Orea i sapatim tingting bilong gavman long kirapim ol tred na wok bisnis bilong en insait long Esia rijon.

Em i tok long bipo, PNG i no save kirapim tumas tingting bilong yusim ol kain kantri olsem Indonesia long ol wok bisnis na tred bilong en.

"Mipela i mas lukluk long Indonesia na yusim wanem samting ol i gat long helpim na kirapim Papua Niugini," em i tok.

Memba i tok dispela kain pasin bilong toktok tasol long maus wantaim ol kantri long Esia i mas pinis. Samting tru i mas kamap na em i amamas olsem Praim Minista i tokaut long dispela.

Mista Orea i tok Papua Niugini i mas gat ol man husat i gat gutpela save long wok i go kirapim ol kain wok olsem wantaim ol kantri insait long Esia rijon.

Em i tok husat ol lain i go stap makim gavman long Esia rijon i mas ol man bilong wok. Olsem bai ol inap bihainim wanem samting em gavman i laikim ol i mekim.

Memba i tokaut tu long askim Praim Minista Wingti long makim wanpela fultaim Tred Komisina long go stap long Singapo. Olsem bai dispela man inap wokbung wantaim ol kantri long Esia long wok bisnis na tred.

Mista Orea em i wanpela memba bilong Palamentri Komiti long wok bilong Difens na Foren Rilesens. Na long dispela mun, em i bin go wantaim Praim Minista long wanpela kibung long Jakata, biktaun bilong Indonesia.

Na long dispela taim, em i stap tu long ol toktok bilong tred na bisnis namel long tupela kantri ya.

Em i stat pinis long toktok wantaim ol papa graun bilong Sentrel provins long givim ol hap graun bilong ol long planim rais. Na helpim bilong dispela bai kam long Indonesia.

Dispela so i bin kamap tu long taim em Papua Niugini i tingim namba wan de bilong em long indipendens long 16 Septemba, 1975. Ol Wes Sepik i kolim dispela so olsem Ats na Kalsa So bilong ol. Na dispela tu i sut long tingting bilong holimpas pasin tumbuna.

Namba tu primia na minista bilong Kalsa na Turisem, Steven Aike i

bin opim na pasim dispela so. So i stat long Trinde, Septemba 16 na pinis long Fonde.

Mista Aike i tok em i laikim dispela kalsarel so i mas go het long neks yia na tu long ol yia bihain.

Em i tok, "Olsem minista husat i lukautim ol pasin tumbuna, mi mas tokim yupela ol pipel olsem mi amamas long dispela kain so i kamap long provins bilong

yumi. Em i taim nau mipela i mas soim ol narapela manmeri long wanem kain ol pasin tumbuna em mipela i gat long en. Na tu ol pikinini bilong mipela long taim bihain bai i save long wanem kain ol pasin tumbuna bilong mipela."

Aike i skruim tok olsem kain kain ol wok developmen i kamap nau long provins na kantri. Olsem na wan

wan man na meri i mas was gut na lukim olsem ol dispela senis i no ken daunim ol pasin tumbuna bilong PNG.

Em i tok ol pasin tumbuna bilong Papua Niugini i wok long senis hariap hariap tumas bihainim ol kain kain tingting na pasin bilong ol waitman.

Long ol turis projek, Mista Aike i tok Wes Sepik i nogat ol kain

samting bilong pulim ol turis i go long provins. Olsem na dispela i givim sans long Wes Sepik long skelim ol gutpela na nogut samting long turis bisnis.

Em i skruim tok tu olsem Wes Sepik i no gat wanpela polisi bilong ol wok kalsa na turis long bihainim. Olsem na ol i wok hat nau long kamapim dispela.



# Kisim gutpela sindaun long pikinini bilong yu

Yu save lukautim gut pikinini bilong yu. Nau yu mas tingting tu long givim gutpela sindaun long pikinini long bihain taim.

Olsem yu mas opim pasbuk akaun wantaim Nambawan

Haus Moni bilong yumi. Stat nau long sevim moni long

peim skul fi, baim ol buk bilong skul na givim gutpela sindaun long pikinini nau bai em i kamap strong.

Askim nau ol wokmanmeri long PNGBC long opim wanpela pasbuk akaun na ol arapela sevis em yu laikim.

Mipela ken halivim famili bilong yu kisim gutpela sindaun long bihain taim... emi tru!

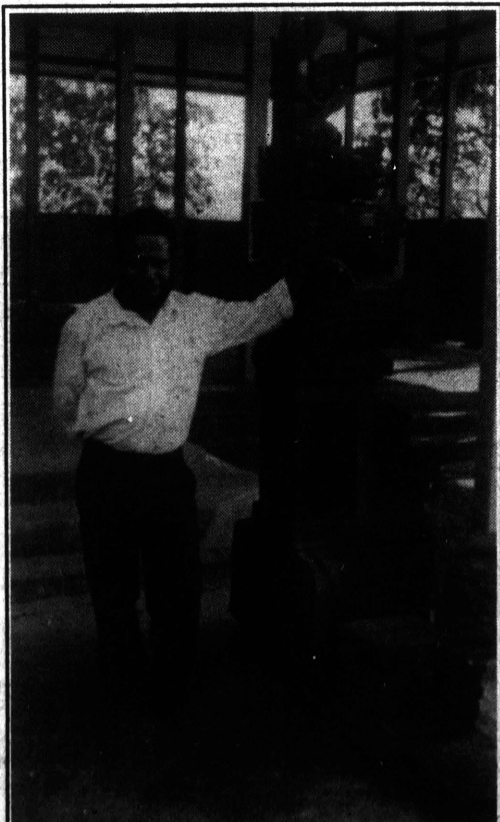

Ston bilong Hindu...Dispela ston em Ronald Sefe i poromanim i save stap insait long haus lotu bilong ol Hindu long Indonesia na ol i stori long ol god bilong ol. Dispela ol hap ston i stap long embasi bilong Indonesia long Mosbl. Foto: Mesery Gubag.

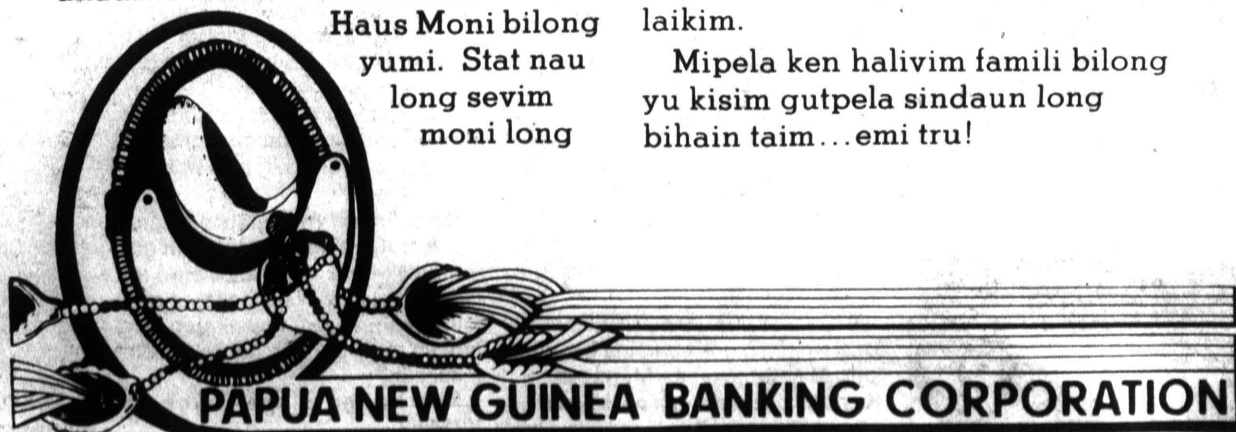

WANTOK

# BISNIS LONG PAPUA NIUGINI

WANTOK

## KOPRA

Pe bilong kopra i go antap nau long K30 long wan wan tan long dispela yia. Pe bilong ol bikpela depo olsem Mosbi, Alotau, Lae, Madang, Wewak, Kavieng, Toboi, Kimbe na Kieta i stap olsem:

Smoke	K263
F.M.S	K265
Hot Air	K268

Na pe bilong kopra long ol liklik depo i stap olsem:

SAMARAI	Smoke	K231
	F.M.S	K233
	Hot Air	K236

KANDRIAN na NAMATANAI	Smoke	K228
	F.M.S	K230
	Hot Air	K233

BUKA	Smoke	K227
	F.M.S	K229
	Hot Air	K232

FINSCHHAFEN	Smoke	K223
	F.M.S	K225
	Hot Air	K228

LORENGAU	Smoke	K198
	F.M.S	K200
	Hot Air	K203

KEREMA	Smoke	K218
	F.M.S	K220
	Hot Air	K223

KARKAR	Smoke	K200
	F.M.S	K202
	Hot Air	K205

CMB nau bai i no inap long kisim moa prais sapot long Gavman. Dispela i stap long Januari 1, 1992

## KAKAO

PRAIS bilong drai kakao long wanwan tan long Rabaul long Mande inap long Fraide long las wik.

Mande	Tunde	Trinde	Fonde	Fraide
7/09	8/09	9/09	10/09	11/09

Pe ol baiya sasim long papa bilong fementri				
K723	K712	K713	K716	K716

Sapot prais				
K418	K418	K418	K418	K418

Prais ol papa bilong fementri i kisim  
K1141 K1130 K1131 K1134 K1134  
Sapot prais bilong kakao long dispela mun em K628.95. Dispela prais i no wankain olsem pe bilong kakao long ol narapela hap bilong kantri.

## KOPI

Pe bilong drai arabika na robusta kopi long wanwan kilogram long Aug 24, 1992. Dispela i karamapim prais bilong kopi long dua bilong faktori, na i no long sait bilong rot.

Arabika :	
Kainantu	K0.92 to 98
Goroka	K0.80 to 97
Minz na Banz	K0.80 to 83
Hagen	K0.80 to 82
Lae	NQ
Mumeng	NQ
Wau/Bulolo	NQ
Madang	K0.75

Ol ripot i kam long Kopi Industri Kopresen. Mipela i no kisim ripot bilong Kundiawa, Wapenamanda, Mendi, Erap, Aseki, na Wasu.

Robusta :	
Is Sepik	K0.50 to 65
Madang	K0.55

Ripot bilong ol arapela senta husat i save groim robusta kopi i no kamap.

## RABA

Gavien faktori (ESP) - 21 t/kg  
Doa faktori (Sentrel) - 36 t/kg inap long 39 t/kg

## KADAMON

Prais bilong kadamon em A. T. Agri Ejensi Pty Ltd long Madang i tok aut long en i stap olsem;  
Drai long san em namel long K0.80 na K1.10.  
Drai long lektori em namel long \$6.50 na \$8.00.  
A. T. Agri i lukautilim Kobum Spice em i stap long Bundi we planti ol kadamon i save kam long en.

## PRAIS BILONG OL BENSIN

Kos long wanpela "lita" Ex Pump (Wantaim takis)	
Petrol	51.9 toea
Diesel	38.8 toea
Kerosin	43.0 toea



## Wok panimaut soim olsem:

# Ol turis yusim moa mani long PNG

JAMES KILA i raitim

MANI ol turis i save tromoi taim ol i kam long Papua Niugini i winim tru ol arapela kantri long Pasifik rijon.

Dispela i bin kamap long wanpela ripot bilong Turisim Kaunsil bilong Saut Pasifik (TCSP) bihain long ol i bin mekim wanpela wok painimaut long 1991. Ol i bin painimaut olsem taim ol turis i save kam raun, ol i save yusim klostu long K1,196 long PNG.

Na dispela i bikpela moa long ol wanwan memba bilong TCSP. Ol arapela samting i stap insait long dispela ripot i tok olsem:

- ol lain husat i save kam long PNG em ol bisnisman, ol lain husat i kam lukim ol famili o pren na ol turis husat i kam raun tasol.
- klostu long hap bilong olgeta lain husat i save

kam raun i bin kam long PNG bipo.

- ol liklik namba tasol i save stap long hotel, na ol arapela ples bilong slip we ol i save baim.
- namba bilong ol de ol lain ya i save stap insait long kantri em 12-pela de.
- insait long olgeta 10-pela pipel husat i bin kam long PNG, 6-pela long ol i save kam long PNG tasol. Na ol arapela em ol lain husat i save raun long ol arapela kantri tu.
- planti ol lain ya i save kam long hia bikos PNG i gat gutpela hap na ples bilong raun, kalsa, viles, bilum, purpur, spia, kafing na ol kain samting olsem, na tu bikos ol pipel i save pren gut wantaim ol turis.

Ol i bin painimaut tu olsem olgeta lain husat i bin kam long PNG na go bek long ples bilong ol i save tok olsem PNG em i wanpela gutpela hap. Na olgeta samting ol i lukim i bihainim laik na tingting bilong ol.

## Nupela bisnis grup kamap long Kimbe

PLANTI provins long Papua Niugini i bin amamasim 17 indipendens aniveseri long Septemba 16. Tasol Wes Nu Briten provins i no amamasim dispela de.

Olgeta bikpela senta insait long Wes Nu Briten bai amamasim indipendens de wantaim provinsal de long Oktoba 5. Bikos provinsal gavman i no gat mani bilong amamas indipendens na bihain provinsal de.

Ol bikpela samting bai kamap long amamasim de ya em; Ousi Ruls tonamen, provinsal soka tonamen, singsing tumbuna na ol arapela bikpela pilai.

Narapela bikpela samting em nupela bisnis grup bilong ol bisnis manmeri long Kimbe konstituensi. Nem bilong dispela bisnis grup em Kimbe Bisnisman na Wimens Asosiesen. Ol i opisal i rejistaim dispela asosiesen long Kampani Rejista las wik.

Dispela i bringim namba bilong bisnis grup insait long Wes Nu Briten i go antap long 4-pela. Narapela tripela em long Talasia, Bileki na Pulabe. Dispela asosiesen i op pinis long ol bisnis manmeri insait long Kimbe konstituensi long memba long en. Membasip fi em K150.

## Ol rurel pipel ken yusim nau nupela sakol bokisais

KLOSTU nau bai wok painimaut na developmen bilong kamap wantaim namba wan sakol bokisais insait long wol pinis.

Dispela nupela sakol bokisais em Dokta Akhtar Haya Uppal na asisten bilong em, Dokta Karo Komuna i wok long mekim. Tupela wantaim i bilong Dipatmen bilong Meknikel Ensineri long Yunivesiti ov Teknoloji long Lae.

Dokta Uppal i tok dipatmen bilong tupela i bin statim dispela bokisais long 1987 na 1988. Em i tok long namba wan taim ol i mekim ol i bin yusim sampela kain samting ol i kolim "sola kolekta" long kisim pawa long san long ranim dispela bokisais.

Tasol ol i bin painim sampela hevi. Long wanem ol i save kisim samting olsem 5 aua pawa tasol long san long ranim dispela bokisais. Olsem na ol i kamap wantaim dispela tingting long yusim ol sakol (sit bilong paia) long ranim dispela bokisais.

Dokta Uppal na Dokta Komuna i tok dispela nupela sakol bokisais em i nupela kain bokisais insait long wol. Na em i gutpela long ol manmeri insait long ol rurel eria long yusim long putim ol kaikai insait long en.

Tupela i tok ol manmeri long ol rurel eria i ken yusim dispela nupela sakol bokisais long putim ol kaikai ol i kukim pinis, pis na ol arapela abus wantaim kumu.



*Goroka bisnisman salim gaden kaikai long Mosbi - Paul Sirai long namel em wanpela bisnisman bilong Goroka. Em i save sallim ol gaden kalkai olsem kabls i kam long Mosbi, na lain bilong em i save sallim. Long Fraide Septemba 11, em i sekim susa na tambu bilong em i sallim sampela kalkai long Godens maket. Foto Eddie Saunders.*

## Lae Siti Atoriti givim pinis kontrak bilong stretim ol rot

LAE SITI Atoriti i bin givim pinis wanpela kontrak i go long wanpela kontraksen kampani, PNG Readymix long stretim ol rot we i bagarap insait long Lae siti

Siti menesa na jenerel menesa bilong Lae Siti Atoriti, Jacob Sawanga i tok long dispela wik olsem dipatmen bilong em i no gat inap mani. Olsem na ol kampani bai i stretim ol rot long tripela mausrot tasol long siti. Ol bai i inap wok long ol liklik strit nabaut long siti.

PNG Readymix i bin winim kontrak long stretim ol rot we i bing bagarap long Milfordhaven na Markham rot. Kos bilong dispela wok em K33,647. Sawanga i tok PNG Readymix i bin

stap wok long stat bilong dispela mun. Bikos ol i bin sot long ol sampela samting bilong yusim long mekim rot. Tasol las wik ol i stat gen long wok long rot.

Sawanga i no bin tok long wanem hap rot long siti narapela kontraksen kampani, Shoncliff bai i wok.

Shoncliff em i wanpela kampani Lae Siti Atoriti bilip bai i wokim gutpela wok long siti. Tasol em i tok PNG Readymix i kisim tokorait pinis long karim narapela wok gen long stretim rot long Huon na Seven Strit maunsrot.

Kos bilong dispela wok em K21,652.

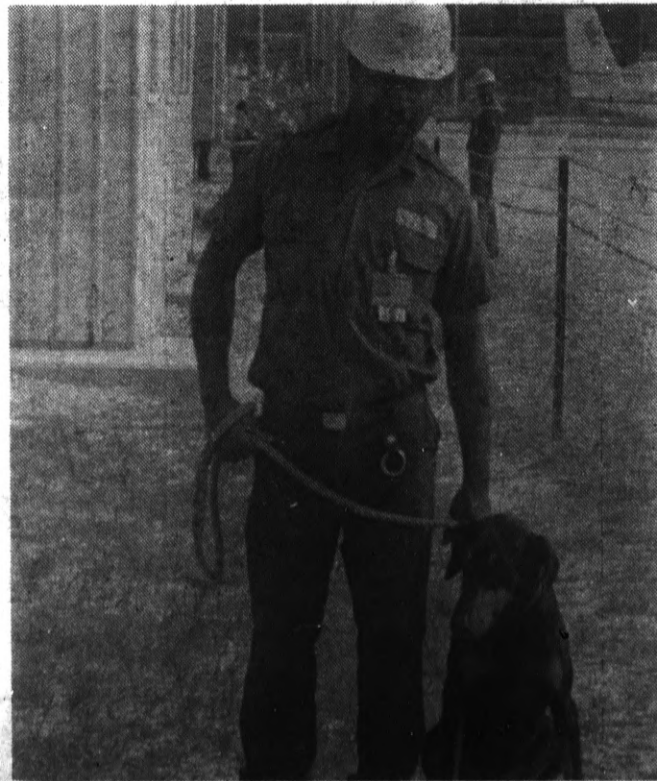

• Sekyuriti bilong lokol sekuriti kampani bilong ol papagraun long Kutubu.



**WANTOK**

# BISNIS LONG PAPUA NIUGINI

**WANTOK**

## Ol smolholda long 14 mail laik tekova

**JAMES KILA i raitim**

OL pipel husat i stap long lig graun long 14 mail ausait long Mosbi i nosave nau long bihain taim bilong ol wantaim kampani, Koita - Oro Boroma Pty Ltd.

Dispela hap em i wanpela ples bilong kirapim ol wok agrikalsa.

Ol i askim nau gavman long glasim gen developmen polisi o plen bilong kampani.

Koita - Oro Boroma Pty Ltd em wanpela smol holda pik projek. Deputi Praim Minista Sir Julius Chan i bin opim dispela projek

long 1980, taim em i praim minista na minista bilong Praimeri Industri. Kampani i yusim dispela hap graun aninit long lis agrimen o tokorait wantaim Illimo Pastoral Kampani.

Koita - Oro Boroma i lisim graun ya i go long manmeri bilong kainkain hap bilong kantri. Ol pipel i aplai na sindaun antap long graun long lukautim pik. As bilong kirapim dispela pik projek em long mekim kamap bikpela ol liklik bisnis insait long kantri. Dispela em ol bisnis ol lokol pipel yet i mas papa long en.

Long wanpela kibung long wiken, ol pipel i pasim tok long

tekova long menesmen bilong kampani sapos gavman i givim tokorait. Kibung i painimaut tu olsem kampani i nogat ol bod ov dairekta.

Ol menesa bilong Koita - Oro Boroma Pty Ltd, Peter Walton na Lavaki Haiveta i stap tu long kibung. Tupela tokaut olsem i no gat ol BOD. Dispela em long oraitim developmen plen, na bihain taim bilong kampani.

Ol pipel i bihainim toktok bilong Sir Julius long 1980 olsem ol i ken tekova long kampani long bihain taim, sapos ol i kisim tokorait.

## Ol pipel stapim gavman projek

OL sapota bilong wanpela kendidet husat i bin lus ong ileksen i bin stapim gavman opisa long lukim Pawari Citrus Projek, insait long Wapenamanda eria bilong Enga provins.

Dispela projek i bilong Divisen bilong Praimeri Industri.

Dispela pasin i bin kamap long mun Ogas. Ripot i tok ol sapota bilong wanpela kendidet i stapim menesa bilong projek long go lukim projek. Dispela pasin i bin kamap tripela taim olgeta.

Asisten Seketeri bilong Wapenamanda, Albert Macsaene i tok ol sapota bilong Frank Iki i rausim menesa bilong projek tripela taim olgeta.

Mista Macsaene i tok em i no save long wanem as na ol pipel i mekim olsem. Dispela em long stapim wok long ol gavman projek long go het.

Em i tok ol sapota i bagarapim tu sampela skul long Lowa Rai rot. Mekim na ol tise i bin ranawe.

"Ol i bagarapim samting bilong ol yet. Ol dispela samting bilong gavman i stap long helpim ol," Macsaene i tok.

Em i tok ol papamama i tokim pikinini bilong ol long noken go long skul. Bikos sapos ol i go skul bai i nogat kaikai bilong en long bihain taim.

"Mi no save sapos ol pipel i laikim olgeta pikinini bilong ol long kamap politisen na tok olsem," em i tok.

## PE BILONG AIR NIUGINI LONG PNG TASOL

KISIM LONG I GO LONG	PE BILONG	BALUS	PE BILONG	KAGO
POM	Alotau	K101		K1.01
POM	Daru	K117		K1.17
POM	Goroka	K114		K1.14
POM	Hoskins	K140		K1.40
POM	Kavieng	K234		K2.34
POM	Kundiawa	K113		K1.13
POM	Lae	K95		K0.95
POM	Madang	K129		K1.29
POM	Manus	K206		K2.06
POM	Mendi	K136		K1.36
POM	Misima	K155		K1.55
POM	Mount Hagen	K132		K1.32
POM	Popondetta	K59		K0.58
POM	Rabaul	K187		K1.87
POM	Tabubil	K189		K1.89
POM	Tari	K153		K1.53
POM	Vanimo	K234		K2.34
POM	Wapenamanda	K141		K1.41
POM	Wewak	K180		K1.80

Ol kago em hevi abrusim l6kg bai gat pe

## Exchange Rates

PNGBC		
Bank buys at:	Notes	T/T
Australia	1.4540	1.4238
USA	1.0780	1.0444
UK	0.5750	0.5526
Bank sells at:		
Australia		1.4128
UK		0.5417
USA		1.0364
Solomon Islands		3.0164
China		5.5980
Fiji		1.5167
Hong Kong		7.9560
India		28.8490
Japan		127.4700
New Zealand		1.8611
Philippines		25.5210
Singapore		1.6410
Switzerland		1.3490
Germany		1.5220
Gold rates (in US\$):		
per ounce		\$346.70
per gramme		\$11.15



**Nupela bisnis asosiesen kibung** • Ol Interim eksekutiv memba bilong PNG Nesen ov Bisnis Asosiesen wantaim ol ripresentativ bilong Smol Bisnis Developmen Kopresen na Friedrich Ebert Faundesen. Ol i bin bung long Mosbi long Fonde 10 Septemba. Dispela em long namba tu kibung bihain long kamap bilong asosiesen. *Poto Eddie Saunders.*

## PTC redi long bringim telipon sevis long Not Solomons

**FRANCIS ULIAU i raitim**

PTC i redi nau long bringim ol telipon sevis i go bek long Not Solomons provins.

Na ol i tingting long mekim dispela samting taim long dispela mun o neks mun. Sapos PTC i mekim olsem, dispela bai helpim tru ol wok bilong stretim toktok namel long PNG gavman, edministresen na ol lain long hap. Na tu ol pipel bilong Not Solomons yet husat i stap ausait long provins i ken toktok wantaim ol famili na poro bilong ol long ples.

Long bringim ol telipon i go long hap, PTC i baim pinis tripela satelait teminel bilong putim long Bogenvil. Dispela ol teminel i gat tupela, faipela na eitpela sanel bilong wok. Na namba wan teminel bilong bringim i go long ailan em dispela i gat 5-pela sanel long en. Wanpela sanel bilong dispela teminel i bilong salim ol toktok long fax masin.

Taim PTC i baim ol dispela tripela teminel, em i bin baim tu wanpela sistem bilong satelait stesin long Gerehu. Na dispela olgeta wantaim i kostim PTC K150,000.

Mausman bilong Telekom Plening Dipatmen bilong PTC, Bill Burgess i tok long Fraide olsem dispela nupela teminel bai helpim wok bilong bringim ol arapela sevis i go kwiktaim long Bogenvil. Na tu ol gavman inap sindaun isi na toktok long wanem samting bilong mekim na stretim hevi bilong Bogenvil nau i wok long go het yet.

Em i tok dispela samting PTC i mekim i bihainim tingting bilong gavman long bringim ol sevis i go long Bogenvil Ailan.

Burgess i tok wok bilong stretim na sanapim dispela ol masin em i isi tru. Na tupela man tasol inap sanapim wanpela insait long tripela de. Olsem na dispela ol nupela satelait teminel i gutpela bilong yusim long ol ples we i gat ol bikpela birua na bagarap long en.

Na i gutpela tu bilong yusim long ol ples bilong painim gol, kopa na wel. Bikos em i isi long sanapim na rausim kwiktaim sapos i gat hevi.

Burgess i tok maski sapos i gat hevi long wanpela hap, dispela i no inap bagarapim ol toktok na sevis bilong ol dispelas telipon lain na fax masin. Em bai wok yet bikos olgeta wok bilong en i save stat na pinis long dispela satelait stesin long Gerehu long Mosbi.

Bihainim dispela wok PTC i mekim nau, em i kirapim tu ol wankain wok long Buka. Na taim ol i pinisim dispela long mun Novemba, em bai saplaim tu telipon sevis i go long Hutjena, Sohano na Nissan ailan.

Tasol olgeta wok em PTC i laik mekim bai stap wetim tasol tok orait bilong nesenel gavman. Tupela man husat bai go pas long ol dispela wok em Rural na Mobail Komyunikesen supavaisa bilong PTC, Brian Forbes na Satelait Projeks sinia ensinia bilong Domsat "A" Stesin, David Price.



• Tupela man husat bai go pas long wok bilong putim telipon na fax lain long Bogenvil. Long lephan em supavaisa Brian Forbes na sinia projek ensinia, David Price. Long baksait bilong tupela em namba wan 5 sanel teminel bilong putim long Bogenvil Ailan.

## Nogat gutpela maket bilong ol Sepik kating

**DAVID ROM i raitim**

PLANTI pipel i gat kainkain rot long kisim mani na sapotim famili bilong ol.

Wanpela rot em long wokim ol at na kraf na salim long pipel bilong ol arapela kantri na bilong dispela kantri tu.

Dispela ol lain husat i save wokim planti gutpela at na kraf em ol grass-rot manmeri husat i nogat bikpela

skul o save.

Tasol long planti hap bilong Papua Niugini, bai yu no inap painim gutpela ples we ol pipel i ken salim samting ol i wokim. Olsem na planti i save salim long maket o long sait bilong rot, na tu ausait long ol bikpela stua.

Sampela lain bilong Is Sepik husat i save wokim kating i save kam long Mosbi na salim samting bilong ol. Bikos ol i no gat gutpela maket o planti man long baim samting bilong ol long provins.



• Bikman ya i salim ol rop bilum na ol arapela tumbuna samting em yet i wokim. Em i save ol samting ya ausait long Ping stua long Boroko.

Planti manmeri i save salim ol samting olsem kating na bilum o mambu kom stat long fran bilong Ori Lavi Haus, Ping stua na Westpac beng, hapsait long Tabari Ples, Boroko.

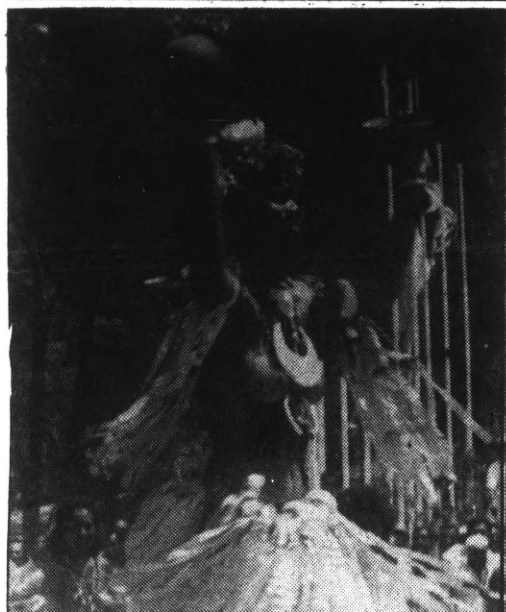

• Redi long resis long Mis Hanenamo long Hiri Moale festival.



• Oi man bilong lukautim dua bilong pilal graun long Madang.



• 1992 Mis Hiri Hanenamo long lephan na namba wan meri husat i kam bihainim em.



• Madang Wimens Basketbal skwa husat i kam namba tri long Basketbal sempnosp long Madang long Indipendens de. Mosbi i bin winim ol long semi fainal na bungim Lae long gren fainal. *Poto: Ben Taumai*



*Klia long ol PX ya...Oi meri PX i so op antap long flot bilong Air Niugini long talm bilong Hiri Moale festival long Mosbi. Dispela bikpela bung i bin kamap wanpela wik pastalm long Indipendens De. Poto: David Rom.*



*Sospen graun...lan Tuntigl bilong Okapa long Isten Hallans provins i sindaun wokim ol sospen long graun ausalt long Walgani Ats Senta. Senta i bin hollm wanpela so ilong las wik Trinde. Poto: Winis Map.*



• Brens eria menesa bilong Coca Cola long Madang, Mista Charlie i sanap namel wantalm Peter Angasa long raithan na siaman bilong Madang festival David Mulul long lephan. Dispela sil bal i stap 6-pela yia olgeta.



*Graunman bilong Asaro...Dispela ol graunman bilong Asaro long Isten Hallans i malolo long talm bilong So na ritim niuspepa i stap. Long bekim dispela, ol i kisim ol fri Wantok singlis tu.*



*Tingim Indipendens...Oi soldla na nevi i redi long alsim flek bilong Papua Niugini long Indipendens Hii long Mosbi long Trinde, Septemba 16. Long dispela de, kain kain samting i bin kamap long kantri bilong tingim de Papua Niugini i kisim Indipendens long Australia. Poto: Ivan Bayagau.*



• Dispela ol yangpela meri bilong Manus na Ecom haiskul i redi long go long ples long kism wan wik malolo. Foto Winis Map

# Ol Sista ov Nasaret wok hat long bungim gen ol Bogenvil pipel

GODFRIED NIAKA i raitim

HEVI bilong Bogenvil i bin stat long 1989.

Na i kam inap nau, planti pipel bilong ol narapela provins na kantri i lusim pinis Not Solomons provins na go bek long ol ples bilong ol. Hevi i stapim tu ol sevis bilong gavman olsem skul na haus sik.

Tasol wok misin i no pinis long Bogenvil. Dispela wok i go het yet. Na wanpela bilong ol kain grup olsem husat i stap wok yet long hap em ol lain bilong Sista ov Nasaret. Ol i save stap long ples Chavbai klostu long Buka basis.

Nau ol i wok long helpim ol pipel bilong Bogenvil. Sampela i save wok olsem ol tisa, nes, pastrol na sosol woka.

Wanpela bilong ol em Sista Lucy Pilisinu. Sista Pilisinu i bilong Buin long saut Bogenvil. Na em i gat 46 krismas.

Mama i bin karim Sista Lucy long 1946. Taim em i kamap bikpela, Sista Lucy i go skul long Piano komyuniti skul long Buin. Bihain long gret 5, em i go joinim ol lain bilong Sista ov Nasaret. Na taim em i pinisim gret 6, Sista Lucy i go long Sen Mary's Asitavi haiskul na wokim gret 7, 8, 9 na 10. Orait long 1972, em i go long Kabaleo Tisa Koles

na kamap olsem wanpela komyuniti skul tisa long 1973. Na em i go bek long saut Bogenvil na stap wantaim ol lain Sista ov Nasaret.

Taim em i stap wantaim ol sista, em i save skulim ol liklik pikinini long komyuniti skul long Chavbai. Tasol long 1979, em i lusim wok komyuniti skul tisa. Na long 1980 na 1981, Sista Lucy i skul long lukautim ol nupela lain meri husat i laik kamap olsem ol Sista ov Nasaret. Em i pinisim dispela skul long 1982 na long 1983 i kam inap long 1987, em i wok long lukautim ol nupela lain meri husat i kamap olsem ol sista.

Nau em i save ranim ol ritrit. Na sampela taim em i save helpim namba wan bos bilong em, Sista Elizabeth Rurehei.

Sista Lucy i tok olsem nau i gat 34 Sista ov Nasaret i stap long Papua Niugini. Namel long ol em 30 i stap long Bogenvil, tupela i stap long Bomana long Mosbi na narapela tupela i stap long Wabag.

Em i tok ol sista long Bogevil i wok hat long traim bringim ol pipel i go bek long ol ples bilong ol. Long wanem planti i ranawe na stap nabaut long bus.

Sista Lucy i tokaut tu olsem ol lain bilong BRA na sekyuriti fos i save rispektim wok ol sista i wokim. Olsem na ol i no bagarapim o mekim nabaut long ol.

## Sepik disasta komiti gat dinau Minista askim ol seketeri na plena long tingim ol meri

i kam long pes 3

Sapos i gat mani, mipela inap long bekim sampela bilong ol dinau ya. Tasol mipela nogat mani na mipela wok long painim hat bikos ol lain mipela i gat dinau long ol i wok long askim askim nau," em i tok.

Long dispela taim yet, Seiloni i tok em i raitim pinis wanpela sabmisin i go long komiti Redio Kalang Apil long givim sampela mani long helpim ol pipel wara i bin bagarapim. Insait long ripot bilong em, em i

askim sapos ol inap long wokim ol et pos long ol 4-pela distrik we haiwara i bin kamap. Em i askim tu sapos ol i ken baim ol tenk wara bilong ol pipel husat i stap arere long riva. Ol distrik ya em Ambunti, Pagwi, Timbungke na Angoram.

Bikos dispela bai helpim ol pipel gut. Em i tok ol lain long dispela hap nau i wok long kism taim tru, tasol em na komiti bilong em i nogat rot long helpim ol long sait bilong mani.

PAPUA Niugini i gat planti kain kain kalsa. Na insait long ol, ol meri em i ol samtling nating.

Ol man i save tok ol meri i no gat namba. Na wanem kain ol nid bilong ol, ol man i no save tingting na traim long helpim.

Dispela ol toktok em nesenel minista bilong Hom Afeas na Yut, Andrew Posai i mekim long asde, taim em i pasim wanpela long bilong "Jenda Plening in Developmen" long Madang. Dispela bung i bilong ol lain long Momase.

Dispela bung i bin stat long Mande na pinis long Trinde,

Septemba 23.

Ol man husat i bin kam long bung em ol seketeri, plena na ol asisten seketeri bilong Momase rijon. Ol i toktok long ol samtling we i save bagarapim ol meri long kantri.

Mista Posai i tokim ol provinsal seketeri, plena na ol asisten seketeri olsem ol i mas sapatim ol progrem bilong ol meri long olgeta kain we. Long wanem dispela bai helpim kantri na ol famili tu.

"Ol meri i kamapim 48 pesen manmeri bilong Papua Niugini. Ol i holim ol politikal na sosol wok insait long kantri. Tasol mipela i no

save klia long ol wok we ol i save mekim," Posai i tok.

Posai i tok planti ol provinsal gavman nau i wok long yusim risos menesmen sistem long traim na stretim dispela hevi bilong ol meri.

Em i tok tenkyu long ol seketeri, plena na asisten seketeri long givim taim bilong ol long kam long dispela woksap. Dispela i soim olsem ol i givim ol yet i go long ol wok bilong ol. Na tu i soim olsem ol i gat tingting na laik long stretim ol hevi we i wok long bagarapim ol meri insait long kantri.

"Nesenel gavman long mun Janueri, 1990 i bin wokim

wanpela "Papua Niugini Wimens Polisi." Dispela polisi i givim pawa long olgeta manmeri husat i mekim wok long developmen bilong dispela kantri long lukim olsem ol meri tu i mas mekim ol wok developmen," Posai i tok.

Em i tok ol seketeri, plena na asisten seketeri i mas kamap wantaim ol plen bilong ol progrem na projek we ol man na ol meri wantaim i mas kism helpim. Na tu em i askim ol long tingting na putim kamap wanem samtling ol i lainim insait long dispela woksap we bai i gutpela long ol provins bilong ol.

## Rot bilong stretim hevi bilong wara long Mosbi no klia

WARA i wanpela bikpela hevi long Mosbi na i save givim hat wok tru long ol lain husat i stap long Mosbi siti.

Sampela setelmen olsem Kaugere na 9-mail i no gat wara inap long samtling olsem 4-pela mun. Wok bilong

stretim na kism wara i wanpela bikpela hevi yet insait long Mosbi siti.

Nau yet Minista bilong Woks, Albert Karo i wok long lukluk long wok bilong salim na kism wara o wara saplai sistem long

Mosbi. Na em bai tokaut long husat bai lukautim wok bilong wara insait long Mosbi siti. Nau yet olgeta wok bilong wara i stap long lukaut bilong Nesenel Kapitel Distrik Komisen.

Karo i tok Mosbi siti i

mas i gat bikpela mani long stretim hevi bilong wara. Ol i laikim moa mani pastaim long ol i stretim hevi bilong wara.

Sapos ol i no gat inap mani, ol bai painim hat long stretim dispela

hevi. Nau yet moa long 300,000 man na meri i stap long Mosbi siti i wok long bungim hevi bilong wara.

Hevi bilong wara bai pinis sapos i gat inap mani na gutpela ol lain i lukautim wok.

## Moa pipel wet long kism mani

i kam long pes 3

taim ol i kam long sekap long aplikesen bilong ol. Na dispela i nogut tru. Bikos planti bilong ol i save kam long ol longwe ples, na save lusim bikpela mani long baim PMV i kam na go bek nating," opisa ya i tok.

"I luk olsem namel long las yia na dispela yia, planti pipel i i go i kam long mipela planti taim tru. Ating ol i abrusim 30 taim pinis," em i tok.



• Ol mama na pikinini long Bomana i mekim wankain samtling long helpim ol yet long wara. Dispela ol mama na pikinini antap long het bilong wara save bikhet olsem na i no gat wara long Mosbi siti. Foto: David Rom



• Ol mama na yangpela long Kaugere i helpim ol yet long wanpela bruk palp wara. Dispela i kamap long olgeta hap bilong Mosbi siti bikos i no gat wara. Na planti man i belhat na brukim palp nabaut long rot. Dispela em wanpela bilong ol dispela palp ol man brukim long en.

# Meri Sio karim pikinini pukpuk



BIPO tru long ples Nambariwa long Sio, Morobe provins i nogat wanpela pukpuk i stap. I gat ol man tasol.

Na bihain wanpela man i maritim susa bilong em yet na tupela i kamapim wanpela pikinini pukpuk. Olsem na nau ol pukpuk i pulap long Nambariwa.

Meri i kam long wanpela famili ol i kolim Sialambu. Na man i kam long narapela famili ol i kolim Bunowa. Long dispela eria i tambu long ol brata na susa i maritim long ol yet. Tasol tupela i brukim dispela tambu na maritim.

Tupela i stap i go na meri i gat bel. Man bilong em i amamas olsem tupela bai i gat wanpela pikinini. Tasol tupela wet i go na meri i karim wanpela pikinini pukpuk.

Meri i no lukim na slip i stap. Tasol bihain ai bilong em i op na em i lukim pikinini pukpuk i slip i stap aninit long lek bilong em. Meri i no gat toktok. Bikos em i karim pikinini pukpuk. Olsem na em i kolim

man bilong em i kam insait long haus na tokim em.

Tupela i no laik long soim ol man olsem meri i karim pinis pikinini pukpuk. Long dispela as na tupela i haitim pikinini i stap insait long haus. Bikos tupela i no laik long olgeta man i save olsem meri i karim pikinini pukpuk.

Olgeta taim tupela bai kukim kaikai na kisim i go insait long haus long givim pikinini pukpuk. Wanpela taim ol man i lukim olsem meri i no gat bel na askim man bilong em olsem meri i karim pikinini pinis o nogat.

Tasol man i sem na giamanim ol olsem meri bilong em i lusim blut tasol na i no karim pikinini. Olgeta man i harim olsem na bilip long em.

Tupela i lukautim dispela pikinini pukpuk i go na em i bikpela. Ol i no save kisim em na raun long ples. Oltaim tupela bai pasim em, na em bai slip i go inap olgeta man i go long gaden, na em bai kam daun painim kaikai bilong em yet long graun. Sapos em i no kaikai em bai wetim mama na papa bilong em.

Dispela pukpuk i mekim olsem na i kilim olgeta pik na kakaruk bilong ol man long ples.

Planti taim ol manmeri i save painim pik na kakaruk bilong ol i lus. Tasol i nogat man i save olsem tupela



manmeri i haitim pukpuk i stap insait long haus na pinisim olgeta pik na kakaruk bilong ol.

Wanpela taim wanpela lapunmeri i tingting long painimaut long wanem samting stret i save kaikai pik na kakaruk bilong ol. Olsem na em i giaman i go long gaden na i kam bek hait long haus na putim was i stap.

Lapunmeri hait i stap na lukim wanpela bikpela pukpuk i kalap i kam daun long haus bilong tupela manmeri na kilim ol pik na kakaruk i stap. Bihain em i lukim san i go daun na ol man i kam long haus. Na em i sisti i go insait long haus bilong papamama bilong em na slip i

tupela na toksave long em i mas ranawe i go na stap long wara. Bikos ol wantok bilong tupela bai kilim em long kilim na kaikai pik na kakaruk bilong ol.

Moning taim tru olgeta manmeri i slip yet na tupela kisim pikinini pukpuk bilong tupela na i go long wara. Tupela tok gutbai long em na lusim pikinini bilong tupela i go insait long wara.

Nau yet dispela pukpuk i stap long wara na solwara long Sio eria. Na em i save raun na kaikai olgeta pik na kakaruk long Sio eria.

Jerry Nonnie Sio - Morobe provins.

mi slip wantaim meri olgeta wiken tasol em no bel

Dia Laiplain, Mi gat tupela hevi. Namba wan em mi bin maritim inap long wanpela yia nau. Na long olgeta wiken, mi save slip wantaim meri bilong mi. Tasol em i no gat bel yet. Na mi no amamas long em. Olsem na long sampela taim, mi no save slip wantaim em.

Namba tu hevi em long olgeta wik, mi save spak na kam long haus. Na mi save yusim moa long K50 long dring bia. Olsem na mi save wari olgeta taim. Bai mi stretim dispela tupela hevi olsem wanem? Plis helpim mi. Dia Pren,



Wanpela taim ol meri Mussau pulim kanu i go long wanpela bikpela wara na waswas i stap. Na wanpela man Arowe wantaim wantaim man bilong Mussau yet i kam na askim wanpela meri long kisim ol long kanu i go long wanpela ailan.

Tupela kalap long kanu na wanpela meri Mussau kisim tupela i go long ailan. Ol i kamap klostu long ailan na win i apim purpur bilong meri Mussau, na Arowe sindaun long baksait i lukim as bilong meri. ya Arowe i pasim ai na singaut long narapela man Mussau long fran.

"Atus roket, yumi pulim ailan i kam klostu tasol meri Mussau i bringim tudak i kam baksait." Taim Mussau harim olsem, em i askim, "Atus roket, tudak i kam long we?"

Yambo Ngatu MOSBI

Kanage wantaim ol lain bilong em ran i kam kamap long ples Japs long Wewak Maprik rot na bensin i pinis. Long dispela ples, wanpela man nem bilong em Matthew i save salim bensin. Olsem na ol i stapim ka na Kanage askim, "Matthew i stap a?"

Yangpela meri i bekim long stall bilong tokples bilong em yet. "Nohapmo, man bilong givim long bensin la moju lhom pinis long taung ol!" Taim Kanage i harim olsem, em i dai stret long lap na wetim Matthew long kam bek long taun.

Meri lukim Kanage lap i go na em i bel kaskas stret long paitem Kanage.

Joe Balwara VANIMO

Kanage draivim wanpela teksi na i go long Boroko. Bagaros i lukim wanpela yangpela meri sanap long bas stap. Olsem na em i stapim teksi na singautim yangpela meri i kam kalap.

Kanage kisim meri ya na tupela raun i go inap tudak olgeta. Meri i tokim Kanage, "plis yu kisim mi i go long haus bilong mi long Loreto Hostel." Draiva harim olsem na senisim gia na draivim teksi i go isi isi long Loreto.

Taim Kanage senisim gia, han i save abrus na i go tasim lek bilong meri. Em mekim olsem i go na tupela i go kamap long Loreto. Kanage stapim teksi na yangpela meri kalap i go ausait na tok tenkyu long em. Bihain em i tanim, lap nogut tru na tokim Kanage olsem, "Yu go opim Baibel bilong yu long Matthew Sapt 7, na ritim lain 7." Kanage i go long haus, opim Baibel bilong em na ritim: "Askim na bai yu kisim."

Peter Sunamist MOSBI



Amamasim bung...Ol mama bilong Slassi long Morobe provins i singsing na pulim ol deleget bilong wan wan 13 distrik bilong Luteran Sios long PNG. Olgeta i bung nau long namba tri kibung bilong ol long Mosbi. Foto: Francis Uliau.

Salim ol hevi na wari bilong yu i kam long LAIPLAIN, P.O.Box 6047, Boroko. Yu ken ringim mipela tu long telepon namba 26 0011. Mipela i no inap autim trupela nem bilong yu long hia.

**WANTOK**

NIUSPEPA BILONG OL PAPUA NIUGINI STRET

**PABLIK NOTIS**

Sapos yu laik advertais, telepon 25 2500 na askim long

PH Min Aiori Ext 203  
John Iagata Ext 215  
Kosinto Fosagu Ext 216  
Bonner Hui Ext 202

## Nesenel Providen Fan bilong Papua Niugini

HELPIM PIPEL BILONG PAPUANIUGINI LONG KAMAPIM GUTPELA SINDAUN LONG BIHAIN.

### NOTIS

Gavman i bin kirapim Nesenel Providen Fan long 1981 long lukautim mani bilong ol wokman i wok wantaim ol praivet kampani insait long PNG. As bilong katim mani i kam long NPF, em bilong helpim ol memba na ol famili bilong ol long sindaun gut long taim bihain taim ol i pinis long wok, dai, kisim bagarap na i no inap long wok moa o nogat rot bilong kisim mani.

Aninit long NPF Lo, Seksen 3 (1) long kantri, olgeta kampani o bisnis husat i gat moa long 25 wokman mas rejista wantaim NPF na putim sampela sevingis mani bilong ol wokman bilong ol long hap.

Long we bilong painimaut sapos wanpela kampani i gat moa long 25 wokman, NPF i save bungim nem bilong olgeta wokman bilong dispela kampani insait long wanpela provins o long ol provins long kantri na kaunim ol olsem wanpela. Dispela lo tu i karamapim ol menesmen we i save bosim ol planti liklik kampani. NPF bai kaunim ol tu olsem wanpela kampani tasol. Dispela lo i karamapim olgeta wokman bilong ol kampani.

Planti ol kampani i rejista pinis wantaim NPF na ol i save givim mani i go long ol olgeta taim. Tasol i gat planti moa kampani husat i no rejista yet. Ol dispela kampani mas rait i go long NPF na kisim ol rejistresen fom ol i kolim SF3.

NPF tu i salim pinis ol dispela SF3 fom i go long olgeta papa bilong ol kampani long pulimapim na salim i go bek. Ol lain husat i no bin kisim ol dispela fom yet mas rait i go na kisim ol fom ya.

NPF i mekim dispela bihainim tasol lo bilong NPF we i karamapim ol wokman bilong ol praivet kampani. Na bihainim NPF lo long kantri, ol inspekta bilong NPF bai sekim olgeta kampani insait long kantri long lukim sapos ol i bihainim dispela lo.

Long nau i go inap Oktoba 31, olgeta kampani husat i no bin rejista wantaim NPF yet mas rait o ringim ol na rejistaim kampani bilong ol. Sapos NPF i painim olsem sampela kampani i no rejista bihain long Oktoba 31, em bai bringim ol i go long kot.

Rait o ring i go long Nesenel Providen Fan o ol eria opis bilong ol long toktok wantaim ol inspekta o long kisim ol rejistresen fom long ol dispela adres na namba:

1. Compliance/Enforcement Division  
P.O.Box 5791  
BOROKO  
PH: 25 8641/25 8148  
FAX: 25 5503

2. Area Manager  
P.O.Box 2079  
RABAUL  
PH: 92 3044  
FAX: 92 3058

3. Area Manager  
NPF Hagen  
C/- Komkui Haus  
MT HAGEN  
PH: 52 3145/FAX: 52 3134

4. Area Manager  
NPF Lae  
P.O.Box 2541  
LAE  
PH: 42 4633  
FAX: 42 5791

5. Area Manager  
NPF Goroka  
P.O. Box 304  
GOROKA  
PH: 72 1294  
FAX: 72 2036

Oi Menesa bilong NPF i tok orait long dispela notis.

**WANTOK**

NIUSPEPA BILONG OL PAPA NIUGINI STRET

**PABLIK NOTIS**

Sapos yu laik advertais, telepon 25 2500 na askim long

PH: Miri Aiori - Ext. 203  
John Iagata - Ext. 215  
Kosinto Fosagu - Ext. 216  
Bonner Hui - Ext. 202

**PRESEN**

Wanpela kamera bilong wok em yet aninit long wara (lukim foto) bilong wok maining i bin lus long solwara bilong Galp bilong Papua. Las de bilong mipela long lukim dispela kamera i drip drip em long 20 Ogas, 1992. Husat man o meri i painim dispela kamera na i no bagarapim na bringim i kam bek long mipela bai kisim K30,000 olsem presen. Toktok long dispela wantaim:

Paul Owens,  
Robins MBS (PNG)  
P.O. Box 1466,  
PORT MORESBY  
Papua New Guinea.

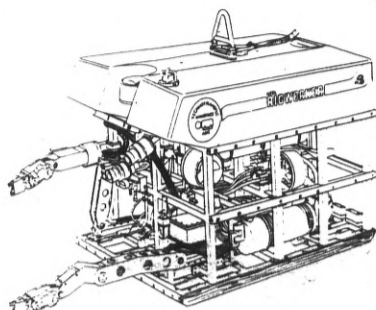

Telipon: (657) 21 7833  
Fax: (657) 21 7823

The Netherlands Insec Co. (Est 1845) Ltd,  
10 Collyer Quay  
#19-08/09  
Ocean Building  
Singapore 0104

Telipon: (65) 5323034 Fax: (65) 5333270

**DO YOU REALLY  
MEAN  
BUSINESS**

?

*Then don't keep it to yourself  
Tell Papua New Guinea through*



PNG  
**BUSINESS**



**AUSTRALIAN  
HIGH COMMISSION**

**PORT MORESBY**

Julie Callard our Overseas Students Officer will be visiting **Goroka** and will be available to answer questions regarding Australian educational opportunities for full fee paying students and student visa requirements.

**VENUE:** BIRD OF PARADISE HOTEL - HAUS KIBUNG CONFERENCE ROOM

**DATE:** TUESDAY, SEPTEMBER 29, 1992

**TIME:** 2 - 5 PM

For further information contact:

Julie Callard  
OVERSEAS STUDENTS OFFICE  
TEL: 25 9333 EXT: 255  
FAX: 25 3528



**AUSTRALIAN HIGH COMMISSION**  
PORT MORESBY

**FULL FEE STUDENTS INTENDING  
STUDY IN AUSTRALIA FOR THE  
FIRST TIME IN 1993.**

**"The school year is fast drawing to a close"**

Information packs outlining requirements for student visas are now available from the Overseas Student Office (OSO) at the Australian High Commission.

To avoid any delays in processing, parents wanting to send their children to Australia for schooling for the first time in 1993 should contact the OSO and obtain the information pack now!

Information material listing schools and education institutions in Australia that welcome overseas students are also available on request.

For further information contact:

Julie Callard  
OVERSEAS STUDENTS OFFICE  
TEL: 25 9333 EXT 255  
FAX: 25 3528





# BENSON & HEDGES SOFTBALL

Wantok

## Bomana sofbal resis go insait long mesa semi fainal

FRANCIS ULIAU | raltim

BIKPELA bagarap i bin kamap taim namba tu tim bilong ol meri long Bomana i wilwilim Prontos long Bomana Wimens A gret sofbal resis.

Bomana 2 i kirapim das long las minit na autim Prontos, 10-8

long Sarere. Olsem na Prontos i tok gutbai nau long 1992 sisen na driman gen long neks yia.

Bihainim dispela win, ol meri Bomana bai go antap long bungim McGregor long Sarere

apinun. Dispela gem bai makim bikpela pilai bilong A gret long dispela wiken.

McGregor bai bungim Bomana 2 bikos ol i bin lus long ol kas nogut bilong Games Village, 14-8. Olsem na Games Village i go stap wetim tasol gren fainal long neks wiken.

Long resis bilong ol meri B gret long maina semi fainal las wiken, ol tambu bilong Kaugere i strong tru na mekim save long Bomana 3, 21-12. Dispela kain skoa i soim tu olsem ol meri Kaugere i min long kamapim bikpela bagarap long B gret resis bilong dispela yia.

Na Games Village i no bin strong tumas na ol yangpela Rebels bilong McGregor i nekim ol, 10-5.

Olsem na long bikpela semi fainal bilong B gret long Sarere, Kaugere bai meknais wantaim



Ramu traim gen...Sampela memba bilong Ramu sofbal tim i kamap long Jack-sons ples balus long Mosbi. Ol i bin kam traim lak long nesanel sofbal sempionsip long Mosbi. Ol kandre bilong ol long Madang i autim taitel. Foto: Eddie Saunders.

### BOMANA WOMEN'S SOFTBALL ASSOCIATION

#### MAJOR SEMI FINAL DRAW: Bisini softball parade

TIME	GRADE	TEAM	GROUND
12.00noon	B	Kaugere vs G/Village	D1
2.00pm	A	Bomana 2 vs McGregor	D1

**Note:**

- All teams are reminded to be at the Bisini softball parade 30 minutes prior to their games.
- All matches will be played on a full seven innings count.
- Town umpires and scorers will officiate so all are asked to cooperate.

Gate Fees: 50toea ADULTS  
30toea STUDENTS

Games Village long belo stret. Dispela tu

bai i statim ol gem bilong dispela wiken.

Mausman bilong asosiesen, Andrew Moe i tok olgeta tim i mas kamap long fil bihainim taim i stap long dro.

"Bikos wan wan gem bai stap inap long olgeta 7-pela ining i pinis. Na tu bai i gat sampela ampaya na skora

bilong taun resis i lukautim ol pilai.

"Olsem na mi laikim olgeta pilaia na ol tim i givim han na mekim ol samting i ran gut," Moe i tok.

Long ol pilai bilong las wiken, presiden bilong Ampayas Asosiesen, Pae Mesak i bin givim bikpela han long lukautim ol gem. Em i lukau-

tim tripela gem na Moe i lukautim wanpela.

Olsem na Moe i laikim olgeta tim na pilaia i kamap long Bisini sofball graun 30 minit pas-taim long gem bilong ol i stat.

Mani bilong baim dua na go insait em 50 toea long ol bikpela man-meri na 30 toea long ol skul pikinini.

## Prontos tok gutbai long 1992 sisen

OL meri Prontos i wok long sindaun silip wantaim wari nau bihain long Bomana 2 i wilwilim ol, 10-8 long A gret eliminesen fainal bilong Bomana Wimens sofbal resis las wiken.

Na ol i no inap sutim tok long husat i asua na ol i lusim sans bilong go insait long gren fainal long dispela yia. Asua i stap long ol yet.

Ripot i tok wanpela as em Prontos i lus em ol meri bilong tim stret i no bin kamap long pilai graun. Bikos ol i gat ol narapela samting bilong mekim. Olsem na ol i kisim ol narapela pilaia na putim long fil.

Tasol bihain ol opisat i rausim gen wanpela meri bikos ol i tok Prontos i brukim lo bilong pilai na

asosiesen long kisim em. Dispela meri i save lukautim bebi bilong wanpela plismeri na i save pilai long Prontos. Tasol ol meri Bomana i toktok planti na rausim em long fil. Olsem na Prontos i pilai wantaim 8-pela meri tasol long fil.

Wanpela ripot i tok, "I no olgeta pilaia bilong Prontos i kamap. I bin gat 6-pela tasol na narapela tripela em ol nupela meri. Ol i kisim bilong pulimapim spes na pilai insait long eliminesen fainal."

Narapela ripot i tok dispela gem i bin isi tru na inap long Prontos i win. Tasol ol i no gat ol ful pilaia bilong ol. Olsem na Bomana 2 i winim gem.



Sampela kain stall bilong ol meri long bikpela nesanel sofbal sempionsip long Mosbi. I luk olsem susa long ralthan i kamap pinis long bes na ketsa bilong ol birua tim i no autim em.



KAVIENG



BUKA



GOROKA



LAE

**PORT MORESBY SOCCER LADDER**  
SEPTEMBER 22, 1992.

Progressive points ladder: Premier Division Week: 21

Teams	GP	Win	Draw	Loss	GF	GA	Pts
Uni	21	14	5	2	49	19	47
Guria	20	11	5	4	35	17	38
K/Andra	21	11	4	6	29	26	37
Rapatona	21	10	5	6	32	27	35
GFC	20	7	6	8	36	31	27
Westpac	21	7	6	7	33	41	26
Koupa	20	7	5	8	34	45	26
Amalpac M	21	6	7	8	23	32	25
Sobou	20	6	3	11	22	33	21
B/Kumuls	21	5	3	11	24	32	20
Golo	20	5	5	10	25	40	20
BFC	19	5	3	11	27	30	18

First Division Week: 21

Verave	23	18	2	3	58	18	56
Moukasi	23	14	6	3	47	27	48
PTC	23	11	9	3	45	20	44
Maset	23	12	3	8	42	35	39
Sunam	23	13	2	9	33	33	38
Bao-Mitas	23	10	8	4	40	22	37
Amazon Bay	23	9	5	9	27	33	32
Defence	23	8	6	9	37	35	31
Steamships	23	6	7	10	25	30	25
Wanzesi	21	5	8	7	20	30	23
Boroko Utd	22	6	3	13	21	34	21
Tarangau	23	5	5	13	23	36	20
Kula	22	4	6	13	20	31	18
PS Roots	23	4	7	17	16	59	10

Second Division Week: 24

Hoods	24	16	4	4	50	14	32
Waliya	23	15	5	3	52	18	50
Mt Obree	23	14	5	5	53	21	47
Kinhill Kramer	22	13	6	3	52	16	45
Fisika	21	12	6	3	52	16	45
Buresong	23	12	5	6	51	20	41
PMGH	24	10	8	6	28	37	38
Gala Utd	20	8	7	5	26	21	31
Cloudy Bay	21	5	12	4	30	28	27
Tubi	21	5	7	9	26	24	22
T Yellow Page	23	5	6	11	26	52	19
Bao-Mitas	22	3	5	14	16	34	14
Amazon Bay	21	3	4	14	16	56	13

U-19 Division Week: 24

Maset	24	15	7	2	51	21	52
Westpac	25	15	5	5	39	16	50
B/Kumuls	24	14	6	4	43	19	48
Golo	25	12	7	6	39	36	43
Guria	24	12	6	6	33	17	42
GFC	24	10	2	5	35	23	40
Amalpac M	24	11	7	8	35	27	40
Sobou	23	11	5	7	30	23	38
Uni	23	8	5	10	24	32	29
Mt Obree	25	8	4	13	23	32	28
Gala Utd	23	7	7	9	21	30	28
Rapatona	23	6	9	8	34	33	28
Koupa	24	8	3	13	26	34	27
Bao-Mitas	23	6	3	14	15	27	21
K/Andra	23	5	4	13	12	37	16
BFC	24	4	3	15	32	39	15

P/Reserve Division Week: 21

Guria	21	12	7	2	40	21	43
GFC	21	11	6	3	44	15	42
Golo	21	12	4	4	26	13	41
University	21	11	3	6	41	23	36
K/Andra	21	10	6	5	30	19	36
Amalpac MU	21	10	4	6	34	26	32
Westpac	21	7	4	9	25	31	28
BFC	19	8	3	7	27	28	27
Rapatona	21	8	3	11	28	27	27
Sobou	21	3	6	12	20	30	15
Koupa	20	4	4	12	12	40	13
B/Kumuls	20	4	-	15	13	34	12

Women "B" Division Week: 23

K/Andra	23	10	1	12	21	27	31
Sogeri	22	9	3	10	15	26	30
B/Kumuls	23	8	5	10	26	32	29
Tarangau	22	8	5	10	18	37	29
Kula	22	7	4	11	14	14	25
T Yellow Page	22	6	1	15	16	35	19
PMGH	21	5	2	14	10	34	17
BFC	23	4	3	14	9	32	15
Golo	23	2	2	19	5	30	8
Koupa	22	-	1	19	6	77	1

Women "A" Division Week: 23

Sunam	23	17	4	2	48	9	55
Wanzesi	21	17	3	2	63	7	53
PTC	23	16	2	5	56	12	50
Guria	22	14	5	3	52	2	47
GFC	23	14	4	5	59	18	46
University	22	13	5	4	48	15	44
Amalpac M. U	21	11	5	5	52	11	39
Waliya	21	11	4	5	38	14	37
Sobou	22	10	2	10	29	22	33

**PORT MORESBY SOCCER ASSOCIATION**  
**WEEKEND DRAW**

SATURDAY 26th SEPTEMBER:

week 11

TIME	DIV	GR	FIX
9.00	Res	Bisini 1	Golo vs Sobou
10.20	Women	Bisini 1	Wanzesi vs Uni
11.40	Women	Bisini 1	Waliya vs G.F.C
1.05	First	Bisini 1	Kula vs Tarangau
2.30	Premier	Bisini 1	Koupa vs B.F.C
4.10	Premier	Bisini 1	Golo vs Sobou
9.00	Second	Bisini 2	Buresong vs Hoods
10.20	Women	Bisini 2	Amalpac vs Guria
11.40	Women	Bisini 2	Sobou vs P.T.C
1.05	First	Bisini 2	Verave vs Defence
2.30	First	Bisini 2	Wanzesi vs P.S Roots
4.10	Premier	Bisini 2	K.Andra vs B.Kumuls
9.00	U/19	G.F.C	G.F.C vs B.F.C
10.30	U/19	G.F.C	B.Kumuls vs Amalpac.m.u
11.40	Women	G.F.C	K.Andra vs T.Yellow Page
1.15	Women	G.F.C	B.F.C vs Tarangau
2.45	Women	G.F.C	Sogeri vs Koupa
4.00	Women	G.F.C	Golo vs Kula
9.00	U/19	Defence	Golo vs Uni
10.30	U/19	Defence	Gala vs Maset
11.40	Res	Defence	G.F.C vs Amalpac.m.u
1.15	U/19	Defence	Mt.Obree vs Sobou
2.45	U/19	Defence	Guria vs K.Andra
4.00	U/19	Defence	Koupa vs Rapatona

SUNDAY 27th SEPTEMBER  
Week 11

TIME	DIV	GR	FIXTURE
9.00	Second	Bisini 1	Kinhill K vs Mt.Obree
10.30	First	Bisini 1	Sunam vs P.T.C
12.30	Reserve	Bisini 1	Guria vs Uni
1.45	Premier	Bisini 1	Amalpac vs G.F.C
3.30	Premier	Bisini 1	Rapatona vs B.F.C
9.00	Second	Bisini 2	C.Bay vs Gala Utd
10.30	First	Bisini 2	Boroko vs Amazon Bay
12.00	First	Bisini 2	P.T.C vs Maset
1.45	Premier	Bisini 2	Koupa vs Westpac
3.30	Premier	Bisini 2	Guria vs Uni
10.20	Second	G.F.C	Waliya vs P.M.G.H
11.40	Second	G.F.C	Fisika vs A.Bay
1.40	Women	G.F.C	Wanzesi vs G.F.C
1.05	Women	G.F.C	Uni vs Guria
4.10	Woman	G.F.C	Morobe vs Sunam
9.00	Women	Defence	T.Yellow P vs Tarangau
10.30	Women	Defence	Sogeri vs B.Kumuls
11.40	Women	Defence	B.F.C vs Kula
1.05	Women	Defence	P.M.G.H vs Golo
2.30	Women	Defence	Koupa vs K.Andra
4.10	Reserve	Defence	K.Andra vs B.Kumul

Bye 1st Moukasi  
Bye Women Sobou  
Bye U/19 Westpac  
Bye Second Tubi T.Yellow Page  
suspended First B.Mitas  
Second B.Mitas  
U/19 B.Mitas



## Lae em king bilong Momase rijn

LAE i soim olsem em i king bilong soka yet insait long Momase rijn taim em i autim Madang, 2-0 long inta-siti kik tupela wik i go pinis.

Dispela kik resis i bin kamap long Madang. Lae i win na kisim Coca Cola sil bilong Madang Festival em Coca Cola sofdring kampani i baim.

Ol oganaisa i makim olsem wanem tim i winim gem tupela taim bai winim dispela sil. Na Lae i kisim.

Long namba wan gem, Madang i bin autim Lae, 2-1. Tasol long namba tu gem, Lae i pait strong na winim Madang. Orait long las gem, Lae i wilwilim gen Madang.

Dispela em ol namba tu tim bilong tupela senta ya. Ol namba wan tim bilong ol i go kik long Manus long nesanel sempionsip bilong B&H Kap.

Kosa bilong Lae, John Peka i bin redim gut ol boi bilong em. Na kain stail bilong kik ol i kamapim long Madang i olsem ol sinia representativ pilai stret. Bikos ol i pilaim gutpela na hatpela futbol.

# Kokopo statim nau ol fainal

FRANCIS ULIAU i raitim

OL fainal kik bilong Kokopo Soka Asosiesen bai kamap long dispela wiken.

Na ol namba wan 5-pela top tim bai resis long primia, risev na wimens divisen.

Long resis bilong ol bikpela man long primia divisen, 5-pela tim husat i winim sia bilong kik long ol fainal em Sapakuru wantaim 22 poin, Is Arowe wantaim 21 poin, Gimi Drifters wantaim 19 poin, Sautkos wantaim 17 poin na Royals wantaim 13 poin.

Ol namba wan 4-pela tim i

bilong ol lain boi Wes Nu Briten. Wanpela ausait tim tasol bilong stap insait long ol fainal em Royals. Dispela em tim bilong ol plisman.

Long ol maina semi fainal primia divisen kik bilong dispela wiken, Royals bai brukim bun wantaim ol loket bilong Sautkos long eliminesen fainal. Husat bilong tupela i lus bai tok gutbai long 1992 sisen. Na wina bai go bungim lusa bilong Is Arowe na Gimi Drifters long narapela wik.

Orait wina bilong Drifters na Is Arowe bai go bungim Sapakuru long narapela wik. Long dispela wik ol boi

Sapakuru i malolo na wetim tasol nupela birua bilong ol.

Presiden bilong Kokopo Soka Asosiesen, Mathew Palah i tok dispela i min olsem bai i gat 4-pela wiken bilong ol fainal.

Long ol narapela samting, Kokopo i no bin salim wanpela tim i go long nesanel taitel kik long Manus. Bikos i bin gat ol paul toktok i kamap na Kokopo i no redi gut long go.

Olsem na long amamasim ol yet, presiden Palah i bin kisim wanpela tim i go kik long Kavieng long Independens De.

Ol i bin kik wantaim tripela tim long hap na bagarapim

tru ol boi Kavieng. Ol tripela tim bilong Kavieng husat i kik wantaim Kokopo em Sen Mathias, Royals na wanpela tim bilong Kavieng Development Skwat.

Long Fraide moning, ol boi Kokopo i kisim sip na go bek long Is Nu Briten provins. Maski ol i win, Kokopo bai tingim yet gutpela helpim na wokbung em Kavieng Soka Asosiesen i soim long ol taim ol i stap long hap.

Olsem na Mista Palah i tok, "Mi laik tok tenkyu i go long ol fain bilong presiden bilong Kavieng Soka Asosiesen, Thomas Warren long helpim na lukautim ol boi bilong mi taim mipela i stap long hap."

## Rabaul fainal wetim ol boi i stap long Manus

OL fainal bilong Rabaul Soka Asosiesen i no inap kamap yet inap ol boi husat i stap long Manus i go bek.

Na dispela bai subim ol samting i stap bek inap long wanpela mun nau. Ol sisen gem i pinis na Rabaul i wetim tasol ol kik bilong fainal resis long kamap.

Presiden bilong Rabaul Soka Asosiesen, Albert Jalmein i tok inap long tripela wik nau, no gat wanpela kik bilong asosiesen i kamap. Long wanem long namba wan wik bihain long sisen i pinis, nesanel kik resis bilong ol meri i bin kamap long Rabaul. Orait bihain tasol long dispela em nesanel taitel long Manus.

Em i tok, "Mipela bai wetim tasol ol dispela lain i stap long Manus long kam. Taim ol i kamap, mipela bai kibung bilong skelim ol rekot bilong ol wan wan klap wantaim bilong asosiesen na tokaut long wanem ol

tim bai stap insait long ol fainal bilong dispela yia."

Ol kik bilong fainal bai kamap long 5-pela divisen. Dispela em long primia, risev gret, anda 49, anda 16 na wimens divisen.

Em i tok tu olsem long dispela yia, ol lain long primia, risev gret na anda 19 i bin pinisim kik bilong ol hariap tru. Tasol ol lain long anda 16 na wimens divisen i bin stap longpela taim liklik bikos i gat planti tim.

Mista Jalmein i skruim toktok olsem ol kik bilong ol fainal inap stat long dispela wiken. Tasol i luk olsem ol pilai bilong Rabaul i stap long Manus i no inap kam bek hariap. Bikos sip i luslain long Rabaul bihain tru. Olsem na bai i no gat gem long dispela wiken.

"Tasol," Jalmein i tok, "Kik resis bilong ol fainal long olgeta divisen bai stat long neks wiken."



Tim tu bilong Lae husat i nekim Madang long winim Madang Festival kap. Dispela kap em Coca cola yet i givim long dispela resis. Foto: Ben Taumai

## Wewak bai salim tupela tim long nesanel klap sempionsip

MESERY GUBAG i ratim

W E W A K S o k a Asosiesen bai salim tupela tim i go pilai long Nesanel Klap sempionsip long Wabag neks mun.

Ol tim ya em Medics na Wewak United. Long poin lata bilong ol long resis bilong B&H Gol Lig resis long provins, tupela tim wantaim i stap long namba wan ples wantaim 18 poin. Na Sunam i stap namba tu ples. Long las yia, Wewak United i bin go pilai long dispela sempionsip.

Presiden bilong WSA, Lawrence Warangi i tok long dispela wiken, tupela tim ya bai go insait long fainal gem bilong dispela B&H Gol Lig resis. Olsem na ol gem bilong WSA bai i no inap kamap.

Ol opisal bilong tupela tim wantaim i stretim

pinis olgeta rot bilong ol long go long Wabag. Dispela em bikos Papua Niugini Futbol Asosiesen i tokim olgeta memba bilong en long painim rot bilong ol yet sapos ol i laik go long sempionsip ya. Na tupela tim wantaim bai lusim Wewak na go long Wabag long dispela wiken.

Dispela i bikos ol fainal gem bilong WSA bai kamap long Oktoba 17 na 18. Warangi i tok tu olsem de bilong olgeta tim husat i laik stap insait long resis bilong neks yia long baim afiliesen fi bilong ol em Oktoba 1.

Long wankain taim, Warangi i kros tu long ol opisal bilong PNGFA. Em i tok ol i bin tok tasol olsem bai i gat wanpela sempionsip. Tasol ol i no

bin toktok gut wantaim ol senta olsem Wewak long stretim tok long ol bai ken save gut long wanem samting bai kamap.

Em i tok dispela pasin i no gutpela bikos ol i go pas long stretim ol kain samting insait long kantri. Na ol i mas tok save gut long ol senta bai ol i ken klia long wanem samting i wok long kamap. Bikos ol i save stap tasol na larim ol senta-nabaut long hatwok na painimaut long wanem samting i kamap.

Warangi i tok PNGFA i bin mekim wankain pasin long ol long taim nesanel soka sempionsip i kamap long Manus. "Ol i bin stap tasol. Na i no tok save long mipela long wanem samting i wok long kamap. Ol i no bin traime long stretim ol toktok," em i tok.

"Mipela i baim olgeta

fi long nesanel bodi pinis. Tasol i luk olsem ol i wok long abrusim mipela. Ol i no laik tok save long mipela long ol progrem. Mipela i wokim samting long tingting bilong mipela yet," Warangi i tok.

Long dispela yia, 11-pela tim i bin stap insait long resis long WSA. Tasol long neks yia, ol i lukluk long kisim wanpela moa tim na bringim namba i go antap long 12-pela.



**BENSON & HEDGES SOCCER**

# Wewak sapota sutim tok long presiden

## GODFRIED NIAKA I raitim

WANPELA soka sapota bilong Is Sepik i tok em i no amamas long presiden bilong Wewak Soka Asosiesen, Dokta Lawrence Warangi.

Bikos presiden i surikim taim bilong maina semi fainal i kam long dispela wik. Dispela kik resis inap

kamap long las wiken namel long Wewak United na Medics. Tasol dispela i no bin kamap.

Em i tok olsem dispela nau i bagarapim olgeta plen bilong asosiesen long redi long bikpela kik bilong B&H Kap long Wabag neks mun. Na tingting

bilong surikim maina semi fainal kik i bilong presiden yet, i no bilong ol eksekutiv bilong Wewak Soka Asosiesen. Na asua bilong dispela i bilong presiden na i no bilong ol klap wantaim ol pilaia.

Ripot i kam long Wewak i tok long taim bilong maina semi fainal, presiden i bin

kisim umben bilong ol golmak na karim i go long Turubu. Long wanem ol lain pipel bilong em i laik yusim long Independens De na pilai long Bernard Narakobi sil.

Olsem na long las wik Sande, olgeta boi United i kam bung na laik brukim bun tasol Medics i no laik. Bikos i no gat umben bilong

banisim golmak.

Dispela Wewak sapota i kros bikos samting presiden i mekim nau inap skruim taim bilong ol arapela fainal i go moa yet. Na dispela i no inap givim inap taim bilong Wewak long redi long bikpela kik resis long Wabag.

Long bekim ol dispela toktok, Dokta

Warangi i tok dispela i no asua bilong em.

Em i tok pastaim long em i kisim umben bilong ol golmak i go long Turubu, ol lain long Turubu i bin salim wanpela opisal leta i kam long Wewak Soka Asosiesen na askim long yusim umben bilong ol golmak long Independens De. Na ol eksekutiv bilong

asosiesen i bin orait long dispela askim bilong ol.

Presiden i tok asosiesen i tok save tu long ol klap olsem ol fainal bai kamap long Oktoba 17 na 18. Na tu olgeta soka referi bilong asosiesen i bin go long is na Wes kos long lukautim ol soka resis long hap long Independens De.

## Tonamen helpim Manus long wokbung

OL spotman na meri i ken bungim ol pipel bilong kantri long wokbung olsem long las yia long namba 9 Saut Pasifik Gems long Mosbi na Lae.

Planti spotman na meri husat i pilai long SP Gems i bin bungim ol arapela pipel bilong kantri wantaim.

Tasol ol lida i no inap bungim olgeta pipel wantaim. Bikos wan wan lida i gat rot bilong em long ranim wok bilong ol pipel.

Provinsal minista bilong Edukesen na Spot long Manus, Michael Kuweh i bin mekim dispela toktok taim em i pasim 1992 Nesenel Skoa sempionsip long Manus las wiken. Dispela bikpela kik resis i bin stat long Trinde, 16 Septemba na pinis long Sande, 20 Septemba.

Mista Kuweh i tok sampela lida i save yusim spot long winim

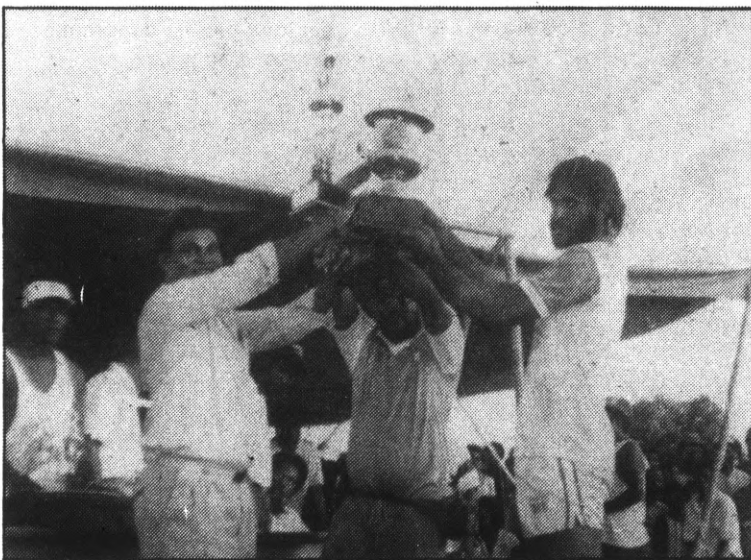

• Kepten bilong Lae Peter Paliwa long raithan wantaim wanpela opisal bilong Lae long namel na provinsal spot na edukesenn Michael Kuweh i soim PNGFA Kap na tropi Lae i winim.

Poto: Winis Map.

sapot bilong ol pipel. Na em i no laikim dispela kain pasin bikos em bai stapim wok bilong ol kain kain pilai long go het.

Sapos ol lida i sapotim spot, ol i mas lukluk tu

long givim helpim.

Dispela tonamen i helpim planti ol pipel bilong Manus-na ol lain husat i kam long ol arapela 11-pela senta olsem Buka, Ramu, Lae, Madang, Wabag,

Hagen, Goroka, Popendetta, Rabaul na Kavieng.

## Lapun Wewak pilaia lusim pilai graun nau

### BEN TAUMAI I raitim

OLPELA intanesenel basketbal pilaia bilong Wewak, Yaom Kesu i tok long lusim pilai nau na wok tasol olsem kosa.

Kesu i autim dispela tingting bilong em bihain long nesenel basketbal sempionsip resis long Madang tupela wik i go pinis.

Em i tok, "Mi painim hat tru long autim dispela tingting. Na tu i no gat wanpela samting i suvim mi long lusim pilai. Em i laik bilong mi tasol long malolo na ating wok olsem kosa."

Kesu i bilong ples Butibam insait long Morobe provins. Em i bin stat pilai basketbal taim em i liklik yet. Long Mosbi, Kesu i save lusim bikpela taim long basketbal na i save pilai long A risev gret bilong Kome Bucks. Tasol i no longtaim ol bos bilong tim i surikim em i go antap long A gret.

Long 1978, em i stap insait long skwat bilong ol meri long Mosbi na i

go pilai long Lae na ol i win. Long dispela taim i kam inap long 1986, em i save stap insait long basketbal tim bilong ol meri Mosbi. Na em i bin stap insait tu long nesenel tim bilong go pilai long Apia Gems na PNG i lus long Fiji long gren fainal na kisim silva medal.

Bihain long dispela em i go long Lae na karim nem bilong asples bilong em i go inap long taim em i go long Wewak na wok long Egrikalsa Beng. Long hap, em i save trenim planti pilaia helpim long kirapim basketbal long Wewak.

Nau Kesu i laik lusim basketbal na givim bikpela tok amamas bilong em na famili bilong em i go long bos bilong em long Egrikalsa Beng. Bikos oltaim em i save orait long Kesu i go na pilai long taim bilong wok.

Long wok bilong basketbal long kantri, Kesu i tok, "Mi amamas tru long lukim olsem ol hailans senta tu i wok long kam antap nau. Na dispela i soim olsem stendet bilong basketbal long kantri i wok long kam antap gut."

## Manus lukautim sempionsip wantaim bel isi

### WINIS MAP I raitim

I LUK olsem Manus i wanpela senta tasol i holim wanpela bikpela kik bilong nesenel taitel wantaim gutpela pasin bilong spot.

Stat long Trinde 16, Septemba i go inap long taim ol i holim gren fainal long Sande, i no gat wanpela pait o trabel i bin kamap. Olgeta pilaia na sapota i soim tru pasin bilong gutpela spot manmeri na olgeta kik i pinis gut.

Bikpela tok amamas i mas go long ol pipel bilong Manus na olgeta pilaia bilong ol 12-pela senta husat i resis long nesenel soka taitel sempionsip.

Ol pilaia i soim tru pasin em gutpela spotman i mas wokim. Olgeta pilaia i amamas tasol na ol i no kros long taim bilong kik.

Narapela samting em yumi mas amamas em, dispela i bin namba wan taim Manus i holim kain bikpela kik olsem. Tasol pasin ol Manus i soim long redim ol samting i winim tru ol arapela senta husat i holim kain kik long taun bilong ol pinis.

Man husat i go pas long redim pies bilong pilai

na ples bilong ol pilaia long slip, Lukas Kanath i mekim gutpela wok tru long wokim dispela bikpela kik i ran gut.

Ol i bin makim 11-pela ples long lukautim ol 11-pela senta husat i go kik long Manus. Ol pipel long ples yet i painim kaikai na givim long ol dispela lain pilaia wantaim opisal.

Dispela ol lain long ples i no lukautim ol long kaikai tasol, ol yet i yusim moto kanu na ka bilong ol long kisim ol pilaia i go i kam long ples bilong pilai. Bikpela tru em ol dispela lain yet i sapotim tim em ol i lukautim. Dispela i helpim olgeta senta long kisim wankain sapot long taim ol i kik.

Taim Wantok ripota i kisim tingting bilong sampela opisal na pilaia long pasin ol pipel long Manus i wokim, planti i tok, ol i no save kisim kain sapot na helpim bilong kaikai taim ol i go pilai long arapela senta o provins.

Planti i tok ol i no inap lus tingting long pasin ol lain long Manus i wokim. Na sampela i tok sapos ol arapela senta i ken wokim olsem, pasin bilong kik long kantri bai kamap gut na planti provins bai kamap pren na lus tingting long ol kain kain hevi ol i gat wantaim ol arapela lain na wokbung wantaim.



• Ol pilaia bilong Lae i amamas long kisim PNGFA Kap long han bilong Madang. Ol i winim Madang 3-0. Lukim moa tim poto bilong nesenel soka sempionsip long pes 24.

Olgeta poto: Winis Map

# MANUS I WIN TRU LONG SAPOTIM WOK SOKA

## PNGFA KAP FAINAL

NEM PNGFA i save kraik long yau bilong ol pipel bilong Manus. Dispela em i bikos planti gutpela soka pilaia i bilong Manus. Na tu planti ol edministreta bilong wok soka tu i bilong Manus. Olsem na dispela nem i save kamaut long maus bilong ol Manus pipel. Tasol long ailan Manus tru, PNGFA i no min wanpela samting long ol. Nogat.

Long Independens wiken stat long Septemba 16 i go inap long 20, ol i klia tru. PNGFA em i mama bodi we olgeta soka asosiesen long kantri i kam aninit long en. Orait, long wan wan taim olsem long dispela longpela Independens wiken, dispela mama bodi i bungim olgeta sinia tim long resis long ol bikpela pilai. Olsem na PNGFA Kap fainai i kamap long Manus. Na planti manmeri pikinini i luksave long dispela

nem na tu long stail bilong kik insait long planti senta bilong kantri. Mosbi, wanpela biknem soka senta i no go kamap long dispela bikpela kik resis.

## OLGETA TUPELA YIA

Dispela taitel i save kamap long olgeta tupela yia. Madang i bin holim taitel long las tu yia. Nau long bikpela kik long Manus, Lae i kisim dispela taitel long Madang na bai holim inap resis i kamap long narapela tupela yia.

Olsem na wanem senta o asosiesen i laik rausim dispela taitel long Lae i mas wet inap tupela yia long traim.

## PNGFA

Planti taim mi save tokaut long PNGFA em i husat tru. Ol politisen, ol spots manmeri na olgeta Manus pipel i soim tru dispela tok long dispela bikpela tonamen.

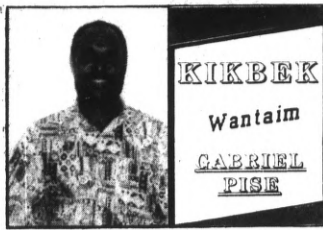

Longtim yet i kam inap long de bilong tonamen, ol politisen na ol wokman bilong Spots Opis na ol bikman bilong soka long Manus i tuhat tru long stretim olgeta rot bilong putim kamap dispela bikpela resis.

Ol senta i salim tim em i kam long Oro, Buka, Rabaul, Kavieng, Lae, Madang, Goroka, Hagen, Enga na Ramu. Wan wan ples insait long Manus i kisim ol dispela tim i go na lukautim ol long ples stret. Ol asples i givim haus slip, kaikai, na trenspot bilong i go i kam long pilai.

Pe bilong olgeta dispela samt-

ing em ol Manus i putim kamap i bikpela tru. Tasol, ol i no wari tumas. Dispela i soim tru olsem nem PNGFA em ol tu i karim. I no ol bikman tasol. Nogat. Bikpela samting tru, ol i laik soim tu olsem pilai soka long Manus i no inap pinis. Maski ol i no gat nem bilong winim wanem taitel, tasol soka i stap long tok-tok na tingting bilong olgeta Manus.

Sapos i gat narapela bikpela soka pilai i kamap gen long Manus, planti ol senta o ol manmeri i laik go lukim i mas. Bilkos dispela pasin ol Manus i soim long bikpela resis ya em i samting yu i no inap lukim long planti taim long laip bilong yu.

## TOK TENKYU

Olsem na long sanap makim olgeta soka manmeri long dispela kantri, dispela kolum i laik givim bikpela tok tenkyu tru i go long olgeta bikman, ol spots-

manmeri na olgeta asples Manus. Maski yu stap we, ol pipel i stap long ples i soim tru gutpasin bilong ol Manus. Tenkyu tru.

## BENSON & HEDGES NESENEL KLAP SEMPION

Narapela bikpela nesenel tonamen bai kamap klostu taim. Dispela em i tonamen we olgeta sempion klap bai kik resis wantaim sempion klap bilong las yia na traim lukim husat klap i gat namba long dispela kantri. Dispela bikpela tonamen i kam aninit long lukaut bilong Benson & Hedges sigaret kampani. Yumi olgeta i was givim bikpela tok tenkyu long bikpela sapot dispela kampani i save givim long nesenel soka.

Yumi olgeta i save olsem long kalenda, dispela tonamen bai kamap long Wabag. Tasol, nau em i stat bilong taim bilong ren long Wabag. Olsem na dispela tonamen bai kamap long Lae.



Dispela pilai bilong Togelu wantaim boal i kusai liklik long wanpela pilai bilong Golo. Dispela kik bilong ol merl long Mosbi soka em i bin kamap long las wiken. Foto: Ivan Bayagau.

# PMSA rausim Bao - Mitas long resis

## LEO WAFIWA i raitim

MOSBI Soka Asosiesen (PMSA) i saspensim o rausim pinis Bao - Mitas soka klap long tripela yia olgeta.

Tambu ya bai i pinis long 1996. Dispela i min olsem Bao - Mitas i ken joinim gen PMSA long 1996 sisen.

Tok orait ya i bin kamap bihain long ol pilai bilong klap i pre-tim wanpela referi na tupela lainsmen long wiken bilong Septemba 19 na 20.

Ripot i tok ol pilai na

sapota i bagarapim tu sampela samting bilong asosiesen insait long dispela trabel.

Bao - Mitas i gat wanpela tim long namba wan, namba tu na anda 19 divisen.

Seketeri bilong PMSA, William Vui i tok asosiesen i kibung na kamap long tok orait olsem Bao - Mitas soka klap i no inap pilai long resis bilong Mosbi soka long tripela yia.

Dispela tambu i karamapim tu ol pilai

bilong namba wan divisen tim husat em nem bilong ol i bin stap long lista bilong pilai taim trabel i kamap.

Tambu ya i no karamapim ol arapela rejista pilai bilong Namba wan divisen tim em nem bilong ol i no stap long lista bilong gem.

Tambu i no karamapim tu ol pilai bilong namba tu na Anda 19 tim.

Mista Vui i tok dispela i no namba wan taim bilong Bao - Mitas long mekim kain trabel olsem. Las yia ol i bin mekim trabel na asosiesen i givim sampela mekim save.

Na Bao - Mitas i promis olsem ol i no inap mekim wanpela trabel long 1992 sisen. Tasol ol i brukim dispela promis.

Olsem na PMSA i givim bikpela mekim save long ol.

Vui i skruim tok olsem PMSA bai tok save long mama bodi, Papua Niugini Futbol Asosiesen (PNGFA) long dispela tambu.

Dispela i min olsem ol pilai bilong namba wan divisen em tambu i karamapim i no inap pilai long resis bilong ol arapela asosiesen insait long kantri husat i memba long PNGFA.

# Wanzesi redim ol tim bilong go long Australia

WANZESI soka klap bilong Mosbi i redi nau long go pilai long Stratford 2000 soka tonamen long Kens, Australia.

Dispela tonamen bai stat long Sande, Oktoba 23 na pinis long narapela wik Sande. Resis bilong ol meri bai stat long Oktoba 23, na bilong ol man long Oktoba 24.

Ekting presiden na tresera bilong klap, David McGregor i tokim Wantok olsem ol bai salim tupela tim olgeta, wanpela bilong ol man na narapela bilong ol meri. Wan wan tim bai gat 15 pilai.

Mista McGregor i tok tu olsem klap i mekim wok bilong bungim mani nau bilong go long Australia. Tupela taim nau klap i holim danis long Airways Motel na kisim sampela mani pinis.

Na tu klap bai askim wan wan pilai long givim sampela mani. Ripot i kam long sampela pilai i tok wan wan pilai bai givim K289.

Mista McGregor i tok long nau yet em wantaim ol arapela eksekutiv memba bilong klap i wok long stretim ol samting. Dispela em long hamas mani wan wan pilai bai givim.

## Primia na risev gret kik laik pinis nau

PRIMIA na premia risev divisen bilong Mosbi soka resis bai pilaim las raun bilong tupela long dispela wiken.

Ol arapela divisen bai pilaim las raun bilong ol

long narapela wiken. Na long namba wan wiken bilong mun Oktoba (Oktoba 3 na 4) bai ol wosaut gem bilong olgeta divisen i stat. Bihain long olgeta

Dispela mani i bilong baim balus, haus slip na kaikai long Kens.

Mista McGregor i plenim olsem tupela tim bai lusim Mosbi long Fonde Oktoba 22 long nait, na kam bek long Mande, 26 Oktoba.

Wanzesi i bin stap insait long dispela resis long bipo yet. Dispela yia bai i namba 7 yia bilong en long go pilai gen.

Nau yet Mista McGregor i raitim wanpela leta i go pinis long PMSA seketeri, William Vui na askim long resis bilong ol meri. Long wanem ol meri Wanzesi i ron namba tu nau long resis, na i gat 100 pesen sans bilong go insait long gren fainal.

Mista McGregor i laik painimaut long wanem taim ol fainal bai kamap. Bikos nogut tim i go long Australia long taim fainal i kamap olsem long las yia.

PMSA i ripot olsem gren fainal bai i kamap long Oktoba 24 na 25.

Mista McGregor i tok sapos tonamen long Kens i kamap long taim gren fainal i kamap, em bai stretim wantaim PMSA long skruim gren fainal bilong ol meri. Dispela em sapos ol meri Wanzesi i go insait long gren fainal.

wosaut gem, gren fainal bai kamap long Oktoba 24 na 25.

Seketeri bilong Mosbi Soka Asosiesen, William Vui i tok em i bilip olgeta gem bai

bihainim plen, na pinis stret long stretpela taim.

Gem bilong ol meri i bin kam bihain liklik long plen. Olsem na long las wiken, ol i stat long pilaim tupela gem.





# BENSON & HEDGES SOKA

## Wantok

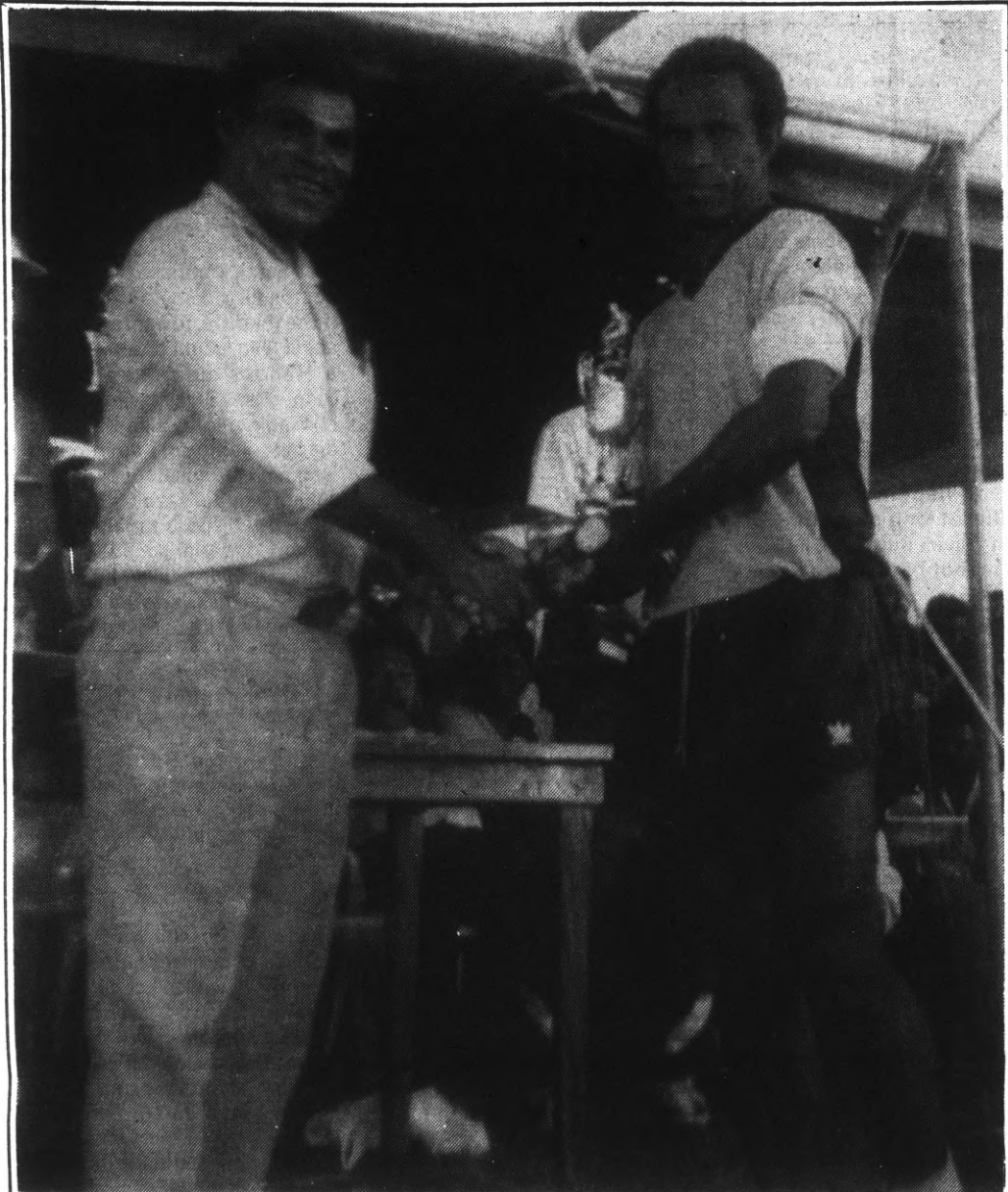

Laviong traim gen...Manus provinsal minista bilong Edukesen na Spot, Michael Kuweh long lephan i givim namba tu ples tropi i go long kepten bilong Madang, Dickson Laviong. Lae i wilwilim Madang, 3-0 na kisim PNGFA Kap. Foto: Winis Map.

### No gat Mosbi tim long Stratford 2,000

**LEO WAFIWA i raitim**

MOSBI Soka Asosiesen (PMSA) bai i no inap salim wanpela tim long Stratford 2,000 soka resis long Kens, Australia.

Dispela resis i save kamap long olgeta yia long mun Oktoba. PMSA i save salim tim i go long dispela ovasis tonamen. Tupela rejista memba klap bilong PMSA, GFC na Wanzesi i save go kik tu long dispela resis.

Las yia PMSA i bin salim sinia tim bilong ol man i go na winim dispela sempionsip long namba wan taim egens ol arapela tim bilong Australia. Tasol dispela yia em i no inap long salim tim.

Seketeri bilong Mosbi soka, William Vui i tok asosiesen i bin kibung na i no orait long salim tim. Bikos i no gat mani.

Kos bilong baim haus slip wantaim balus i stap namel long K7,000 na K8,000.

"Dispela kain mani em mipela i no save baset long en. Mipela i ken kisim long sampela hap olsem long sponsasip long salim tim," Mista Vui i tok.

Mista Vui i tokaut liklik olsem asosiesen i no baim sampela kos bilong las yia. Olsem na dispela i mekim hat liklik long salim gen tim long dispela yia.

Tim bilong las yia i gat planti nem pilaia bilong primia divisen aninit long lukaut bilong kosa Kolis Pom-buai. Tim bilong 1990 i gat planti namba wan divisen pilaia, na Mark Basausau i bin kosim dispela tim.

Mista Vui i tok em i gutpela long salim ol junia tim olsem bilong namba wan na tu divisen long ol kain ovasis tonamen. Bikos dispela bai helpim ol pilaia long lainim moa gutpela stail bilong pilai.

PMSA i bin laik makim ol pilaia bilong namba wan na tu divisen long go daun pilai long Kens long Oktoba. Mekim na planti yangpela pilaia i bin putim yau long harim olsem ol i stap insait long tim i nogat. Tasol i nogat nau.

Seketeri Vui i tok long neks yia, asosiesen bai salim wanpela tim.

Vui i skruim tok moa olsem dispela yia, asosiesen i no kisim bikpela mani. Na tu i no gat sponsasip. "Liklik mani i save kam long ol registresen na afiliesen fi tasol."

### INSAIT long WIK

• PMSA rausim Bao-Mitas...p27

• Kokopo redi nau long ol fainal...p25

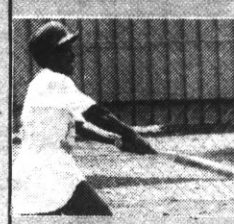

Bomana soibal fainal...p23

• Lae em king bilong Momase..p25

• KIKBEK i tingting...p27

• Wewak sapota sutim tok...p26

# Lae TKO long olupela sempion

**WINIS MAP i raitim**

LAE i bagarapim Madang na kamap nupela soka sempion gen long kantri. Ol boi Wopa i winim ol lain olupela sempion, Madang 3-0 long gren fainal bilong PNGFA Kap long Manus las wiken.

Lae i soim tru stail long Sande taim ol i sutim tripela gol na Madang i no gat. Papua Niugini Futbol Asosiesen i sponsaim bikpela prais bilong dispela resis.

Man husat i helpim Lae long rausim taitel long han bilong Madang na kisim Kap em Gidas Bayung. Bayung em i wanpela

intanesenel soka pilaia bilong PNG husat i sutim tripela gol wantaim.

Olgeta gol bilong em i kam long ol tripela penelti kik Lae i kisim.

Taim Wantok i kisim tingting bilong Bayung long ol dispela gol, em i tok, "Mi no bilip long ol gol mi sutim. Tasol mi amamas long lukim tripela bal mi kikim i brukim umben bilong Madang."

Long taim bilong tonamen stat long las wik Trinde i kam, Bayung i no bin sutim wanpela gol liklik. Tasol long gren fainal, em i kirapim pawa bilong em na sutim olgeta gol bilong Lae.

Lae i soim olsem ol i gat bikpela laik long winim gren fainal taim

ol i kamap wantaim 6-pela intanesenel pilaia bilong ol. Dispela ol man em Akanda Gidigia, Peter Palinae, Gidas Bayung, Raymond Nasa na Godfre Daruhi, wanpela intanesenel pilaia bilong Vanuatu.

Dispela ol lain i bin givim bikpela han tru long Lae na bagarapim sindaun bilong ol boi lait toktok bilong Madang. Gutpela sapot pilai long tim bilong Lae i bin kam long Manangi Simongi, Dennis Agebo, Tony Mirotohi, Alwin Nema na Joe "Chicken" Inchigia.

Madang i pait strong tru long bekim ol dispela gol, tasol lek bilong ol straika i no makim stret umben.

Kepten straika Dickson Laviong na Trimo Topio i traim sutim ol gol tasol Palinae i sambai oltaim long stapim tupela. Maski taim Fred Tonten i laik traim samsam liklik long midfil, stail bilong em tu i go wara nating. Bikos beklain bilong Palinae na ol boi bilong em i strong olgeta.

Tonten i strong i go na lusim fil. Bihain na Ondo Bart i go insait senisim em.

Lae inap sutim moa gol tasol oltaim dispela gras tantanim boi bilong Madang, Alfred Gabong i sambai na banisim ol.

Printed and published by Anna Bernadette Solomon, of Bitten Place, Gordons, at Allotment 2, Section 209, Hohola.





# RUGBY

Namba 67

Fonde, Septemba 24, 1992

LIG NIUS

## Las de

### PNGRFL laikim afiliesen fi bipo long Novemba 28

**SAM YAKAM I raitim**

LAS de bilong olgeta memba lig bilong PNGRFL long baim nominesen fi bilong 1993 sisen em Sarere Novemba 28.

PNGRFL i bin holim las bikpela kibung (AGM) bilong em na makim dispela de.

Las wik nupela Buka Ragbi Lig i baim K2 000 afiliesen fi bilong em i go long PNGRFL. Wok i stap nau long han bilong PNGRFL yet long skelim olgeta ripot bilong Buka lig, na putim em long wanpela lebel.

Edministrata bilong PNGRFL, Jack Metta i tokim Ragbi Lig Nius olsem i gat tupela lebel long olgeta senta i pilai long en. Dispela sistem bai stat long 1993 sisen.

Aninit long dispela sistem, olgeta lebel wan senta bai baim K3 000, na i no K2 000 olsem ripot bilong bipo i bin tok. OL lig i kam aninit long lebel wan bai kisim hap mani bek, na baim K1 000 tasol.

PNGRFL bai glasim ripot bilong wanwan lig, na bihain mekim tokorait long wanem lig bai i kam aninit long dispela tupela lebel.

Sapos wanpela lig i givim olgeta samting long PNGRFL olsem mani ripot, nem bilong ol nupela eksekutiv, namba bilong ol klap na ol pilaia, na ol arapela ripot we i bihainim mamalo bilong mama bodi, em bai kam aninit long lebel wan.

Dispela i min olsem lig ya i mas baim narapela K1,000 gen long bungim mak bilong nupela nominesen fi. Nau yet 9-pela senta olgeta i pinisim K2,000 nominesen fi bilong ol.

Tasol Kiunga wanpela i baim K1,500. Na promisim PNGRFL long baim narapela K500 bipo long AGM. Ol arapela senta husat i pinisim

K2,000 nominesen fi olsem ripot i tokaut long bipo em Mosbi, Lae, Hagen, Goroka, Rabaul, Minz, Buka na Tabubil. Dispela em 8-pela senta tasol.

Metta i tok planti senta i painim hat long baim nominesen fi hariap bikos ol i nogat mani. Olsem na ol bai wet i go inap neks yia. Olsem na ol i save wetim stat bilong nupela sisen, bai ol i ken kisim mani long klap afiliesen gi pastaim.

Metta i tok dispela hevi i kamap bikos sampela senta i no gat gutpela get long oval bilong kisim mani long ol manmeri i go insait long lukim pilai. Long dispela as na ol i nogat rot long bungim mani hariap long baim afiliesen fi.

Tasol Metta i tok strong yet olsem las de bilong baim nominesen fi em Novemba 28, 1992. Wanem lig i no baim fi bipo long dispela de bai i no inap memba wantaim PNGRFL.

Ol eksekutiv bilong PNGRFL bai kibung long Novemba na lukluk long olgeta ripot bilong wanwan lig. Wanem lig i salim nominesen fi na olgeta ripot bilong em long dispela kibung we PNGRFL i laikim, dispela lig bai kam aninit long lebel wan.

Sapos wanem lig i no lukim nem bilong em long lebel wan, em i min olsem em i no salim ful ripot bilong em. Na tu i no baim ful afiliesen fi bilong em.

Metta i tok planti taim hevi i save kamap long wanwan senta. Bikos ol i no gat gutpela ripot. Olsem na PNGRFL i mekim nupela lo bilong olgeta senta i mas wok bung long kirapim bikpela ragbi lig insait long Papua Niugini.

Em i tok olgeta samting ya i bihainim nupela mamalo bilong PNGRFL.

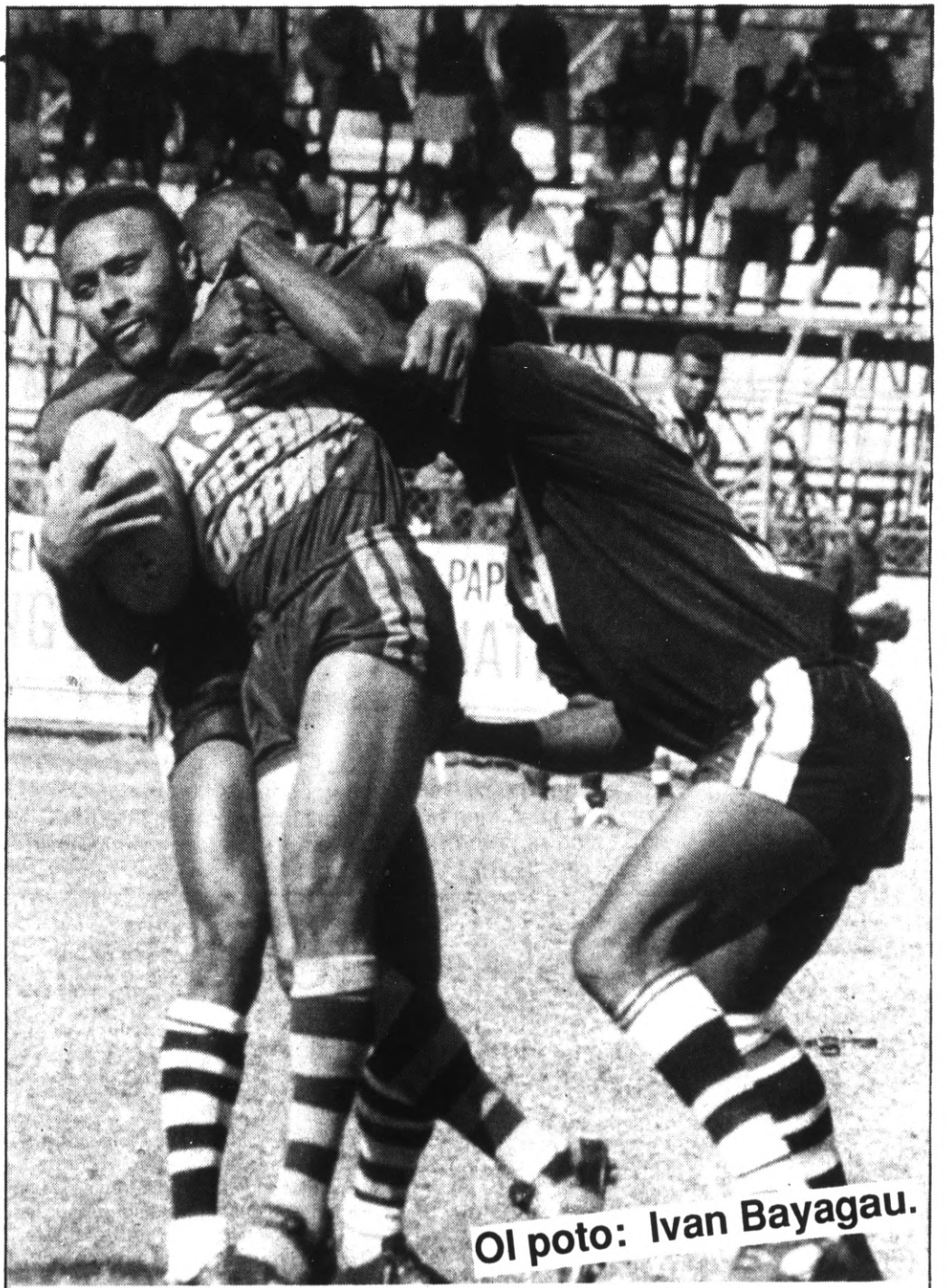

Ol poto: Ivan Bayagau.

*Krewanty soim stail* - Olpela Kumul winga Arnold Krewanty bilong Mosbi Difens i soim strong bilong em egens tupela Kerema Kouri pilaia long namba wan raun bilong 1992 Cambridge Kap resls long Lloyd Robson oval las Sande. Ol soldia bol i win 42-8. **LUKIM MOA RIPOT LONG PES 2 NA 3.**

# CAMBRIDGE CUP

## P.N.G. Big League

## Royals win long 2 poin

TABUBIL Royals i winim Kiunga Souths long namba wan resis bilong Cambridge Kap 14-12. Dispela gem i bin kamap long Kiunga long Sande Septemba 20, 1992.

Kiunga Souths i pilai gut long namba wan hap bilong pilai. Tasol dispela gutpela gem i senis i go nogut olgeta long hap taim. Bikos Tabubil Royals i senisim gem plen bilong em. Na pasim olgeta sans bilong Kiunga Souths long skoa bihain long hap taim.

Long namba wan hap, Souths i bin putim strongpela gem. Na dispela i pusim Royals long mekim planti paul pilai na rong insait long iii. Long dispela as na Souths i lukim tupela gutpela sans na skoarim tripela trai.

Namba wan trai em fulbek Somo no Maitona yet i mekim wanpela strongpela ran na brukim banis bilong Royals. Trai ya i kamap long 10-epa minit i go insait long namba wan hap.

Konvesen bilong dispela trai i no gutpela na skoa i stap 4-0. Bihain winga Busisi Dadimo i lukim narapela sans long sait na sisti long sait lain i go skoa. Konvesen bilong dispela trai i gutpela na bringim Souths i go pas long skoa 10-0.

Souths i pilai wankain stail i go na pusim Tabubil Royal long mekim sampela paul pilai insait long fil. Dispela i givim sans long Souths long kikim wanpela konvesen long bringim skoa i go antap 12-0.

Ol plisman i lukim olsem dispela mak bilong skoa i no gutpela. Olsem na ol i tromoi bol i go i kam na kamapim wanpela spes long beklain bilong Souths. Dispela i givim sans long winga Luke Angur long skoarim namba wan trai bilong Royals 7-pela minit bipo long hap taim.

Tupela trai bilong Souths i kamap long namba wan bihain long gutpela bal wok bilong ol yangpela fowat olsem Dalu Gaela, seken rowa Eric Kutika na Paul Merebe. Dispela tripela pilaia i bungim pilai gut na givim bikpela het pen long ol plisman.

Strongpela man bilong Royals, Tony Nasu wantaim seken rowa Roxon Undi na lok Izoizo i traim hat long bekim trai bilong i go moa long pes 3

## Ol Mosbi Difens pilaia autim stail



• Lok bilong Difens, Oscar Oksap i holim bal long tupela han na ran i go antap long brukim banis bilong Kerema Kouri long namba wan raun bilong 1992 Cambridge Kap tonamen las Sande.



• Smok balus winga bilong Mosbi Difens, James Miviri i bungim takel bilong wanpela Kerema Kouri pilaia. Ol boi Kerema i no strong na lus 42-8 long Lloyd Robson oval. *Ol poto Ivan Bayagau.*

## Mosbi Difens flai i go long Tabubil

IAN KAKARERE i raltim

MOSBI Difens bai flai antap long planti maunten i go long pilai egens Tabubil Royals long namba tu raun bilong Cambridge Kap resis. Dispela gem bai kamap long Tabubil Ragbi Oval long Sande Septemba 27.

Las wik Difens i nekim Kerema Kouri 42-8 long Mosbi. Na Tabubil Royals i bagarapim sindaun bilong Kiunga Souths 14-12. Olsem na ol plisman bilong Tabubil bai traim olgeta strong long daunim ol soldia boi bilong Mosbi.

Dispela wiken bai i namba wan taim bilong Difens long go pilai wanpela tim bilong ausait senta long 1992 Cambridge Kap tonamen.

Ripot i tok ol eksekutiv bilong Tabubil Ragbi Futbol Lig i bin askim olsem Mosbi Difens i mas go pilai long ples bilong ol. Na PNGRFL wantaim ol ogena isa bilong tonamen i yesa long dispela.

Nau yet Tabubil Royals i redi tasol long mekim olgeta samting ol i ken long daunim ol soldia boi husat i gat 100 pesen sans long go insait long gren fainal.

Kosa bilong Royals, Cornell Daipo

i tokim Ragbi Lig Nius olsem gem bilong las Sande egens Souths i olsem wanpela gutpela trening gem bilong ol. Olsem na dispela Sande oli redi gut tru long putim olgeta strong na stail long autim Mosbi Difens.

Daipo i tok ol boi bilong em bai bihainim gem plen bilong ol. Na ol bai i no inap pulap long wanpela hapbilong fil long takelim wanpela biknem pilaia bilong Mosbi Difens.

Em i tok pilai graun bilong Tabubil bai helpim ol boi bilong em tu long stapim tripela smok balus bilong Difens, Arnold Krewanty, Jack Uradok na James Miviri.

Royals bai lukluk long tupela prop bilong em, Tony Nasu, Ita Kuna na seken rowa Roxon Undi wantaim lok Nonme Izoizo. Sapos ol i lukautim pilai gut long fran lain, ol bai i gat sampela sans long win.

Long beklain em Ino Begofa yet bai lukautim long stiam pilai i go inap ful taim. Begofa i gat spit na strong long brukim banis na skoa sapos Difens i no lukautim o makim em gut.

Difens i gat bikpela sans long winim dispela gem. Bikos em i gat planti nem pilaia olsem Kumul kepten Kera Ngaffin, Kes Paglipari, na Jack Uradok.

## Klia long Hagen Hawks

HAGEN Hawks i smelim pinis 1992 Cambridge Kap taitel. Na i luk olsem em bai nekim Mendi Bulldogs long namba tu raun bilong resis long Sande Septemba 27.

Las Sande em i bungim sempion klap bilong Simbu, Kundiawa Tigers na i win 24-22. Dispela i bin wanpela strongpela gem. Olsem na Hagen Hawks i mas bihain wankain gem plen long winim ol boi Mendi.

Tasol em i no inap long win isi. Kepten bilong Hawks, John Pasingan mas i gat wankain gem plen, na tu stapim ol boi bilong em long mekim planti paul pilai insait long fil. Na tu em i mas lukluk long olgeta isi stail bilong ragbi lig long winim Bulldogs. Sapos Pasingan i stretim olgeta hevi ya, em bai win.

Las Sande Hawks i winim Kundiawa Tigers long beklain. Dispela i soim gutpela gem bilong Felix Naea na David Gomia. Olsem na dispela Sande fulbek Laik Tiam tu i mas pilai wankain stail na helpim Gomia wantaim Naea na faiv eit Moses Piandi. Sapos ol i bungim pilai gut, Hawks bai winim Mendi Bulldogs long liklik skoa.

Tasol Mendi Bulldogs i winim gren fainal long senta bilong em namba wan taim, taim em i memba wantaim Mendi Winfield Lig. Olsem na em bai i no inap givim dispela gem i go long han bilong Hagen Hawks isi.

Sapos Hawks i laik winim dispela gem, em i mas pilai hat na stapim olgeta paul pilai. Bikos ol yangpela pilaia bilong Bulldogs bai i no inap pilaia kaskas. Kepten Moses Holly

Kelly i gat bikpela bilip long ol boi bilong em. Na i luk olsem ol bai givim bikpela het pen long Hagen Hawks.

Kelly yet bai i go pas long fran lain. Na em bai kisim helpim long Nicklem Warea, John Manua, Peter Waka na prop Erick Joe.

Long win em Kumul pilaia Joe Rema bai lukautim. Na faiv eit posisen em Moxie Yore yet bai i go pas long en. Long hap bek posisen em Paul Max yet bai lukautim. Na sapos Max wantaim Yore i lukautim beklain gut, na stiam ol boi bilong tupela long fran, Bulldogs bai win.

Kelly i tokim *Ragbi Lig Nius* olsem em i gat bikpela bilip tu rispek long ol boi bilong Hagen. Tasol em i givim tok lukaut olsem. "Ol i mas pilai gut na bihainim gem plen bilong ol. Sapos ol i abrus liklik long olgeta gem plen na tu i no stiam gut pilai, mipela bai tanim tabol long ol."

"Mipela i gat tupela gutpela senta, Joe Warea na Moore Kelly long go pas long skoa. Tupela i gat nem long stapim ol pilaia insait long mak bilong ol. Na sapos tupela i bungim pilai gut, Hagen Hawks bai i nogat sans long ran i go insait long mak bilong Mendi Bulldogs," Kelly i tok.

Nau yet Bulldogs i gat planti ol nupela pilaia. Tasol i tuk olsem Mendi bai givim bikpela het pen long Hagen. Na wanem tim i pilai gut na i no mekim planti rong insait long ful 80 minit bai i win.

Sapos Hawks i laik win, em i mas bihainim gem plen bilong em long las wik.

# Madang Royals mas wokhat long daunim Lae spiders

**SAM YAKAM i raitim**

MADANG em i wanpela liklik senta insait long Papua Niugini. Tasol stat bilong 1980 i kam inap nau, em i gat nem long planti bikpela pilai. Wanpela bikpela gem we Madang i gat nem long en em ragbi lig.

Las yia i kam inap nau, Madang Winfield Lig i kamapim planti gutpela pilaia bilong Noten Son. Na tu long son trails, em i save pretim planti arapela senta bilong noten son. Dispela yia strongpela A gret tim bilong Royals i winim gren fainal bilong Madang Winfield Lig na resis long namba wan taim long Cambridge kap tonamen.

Long namba wan gem bilong las wiken, Royals i winim brata tim bilong Wewak, Wewak Royals 26-12. Olsem na dispela Sande long Septemba 27, em bai ran longpela rot long pilai namba tu gem egens Lae Spiders long Lae Siti.

Nau yet Spiders i gat planti ekspirians pilaia long ol bikpela

gem. Olsem na Royals i mas putim kamap strongpela gem long stapim Spiders i putim moa trai.

Kepten Rex Apuka i tok ol boi bilong em i rispektim ol pilaia bilong Spiders. Tasol em i gat bilip long ol boi bilong em. Apuka i tok wanem tim i pilai gutpela na strongpela gem insait long ful 80 minit bai i win. Apuka yet bai pilai long franlain wantaim tripela raithan pilaia bilong em olsem Eric Mamane, Nonondi Afuti na strongpela huka Ambrose Gitai. Sapos 4-pela i bungim pilai wantaim long fran lain, ol bai stapim Spiders long ran i go insait long mak bilong ol. Na sapos ol i pilai wanwan bilong ol yet, Spiders bai putim strongpela umben na winim Royals nogut tru.

Apuka i mas ritim gem bilong ol pilaia bilong em. Lukluk long ripot bilong Royals, Royals i gutpela long tromoi bal i go i kam. Na sapos Apuka i stiam bal gut em inap paulim ol pilaia bilong Spiders.

Long beklain em Martin Mamana, Otto Eksy Bani, Joe

Goie, na Hinson Kiala yet bai i go pas long lukautim. Dispela 4-pela pilai tu i gat nem long posisen bilong ol. Olsem na ol i mas ritim gem bilong ol yet na pilai strong long stapim Spiders.

Na sapos ol i no stretim lain ap na bihainim gem plen bilong ol, Spiders bai bagarapim sindaun bilong ol. I gat bilip olsem Spiders i gat gutpela lain ap long daunim Madang Royals.

Hia em lain ap bilong Spiders; Fulbek Krilix Joel, lep winga Jacob Danny, ausait senta Andrew Goime, insait senta Charlie Vee, rait winga Paul John, faiv eit Molet Nunu, hap bek Claudi Ario, prop Mathias Kin, huka John Bob, prop Lawrence Gendi, seken rowa Ignas Simbal, seken rowa David Miamel na lok Jack Namapo.

Vee bai i go pas long stiam bol long beklain. Na em bai lukluk long tupela winga, Jacob Danny na Paul John long skoarim moa trai. Olsem na Madang Royals i mas wokhat i go inap fultaim long stapim Spiders long winim dispela gem.

# Muruks kam bek wantaim olupela stail

RABAUL Muruks, olupela sempion bilong Cambridge Kap tonamen i statim olupela stail gen long nekim ol arapela senta wantaim bikpela skoa. Las wik em i nekim Talasia Norths bilong Kimbe 52-0. Dispela i soim olsem Muruks bai mekim wankain samting long ol arapela senta sapos ol i no banisim trai lain bilong ol gut.

Ripot i tok namba wan gem egens Talasia Norths i olsem wanpela wansait gem. Na tu i no luk olsem Cambridge Kap resis. Olsem na ol arapela bikpela senta i mas redi long stapim Muruks.

Long Sande Septemba 27, Goroka Royals bai bungim Muruks long Kwin Elizabeth Oval long Rabaul. Olsem na Royals i mas redi na stretim olgeta liklik hevi bipo em flai i go long Rabaul. Bikos Muruks bai i no inap pilai kaskas long ol bikpela na strongpela senta olsem Goroka.

Nau yet Muruks i putim ai pinis long bungim Difens husat i holim yet Cambridge Kap taitel. Las wik Difens i nekim Kerema Kouri 42-8. Na i luk olsem em tu i gat wankain tingting.

Strongpela na olupela memba bilong Muruk, Andrew Ilam i tokim *Ragbi Lig Nius* olsem ol arapela senta i mas lukaut long Muruks. "Dispela yia em i yia bilong mipela. Na nau mipela bai kilim skin long kisim Cambridge Kap i kam bek long Rabaul long narapela yia gen," Ilam i tok.

Nau yet Muruks so op olsem em i gat sampela nem Kumul pilaia olsem fulbek Normyle Eremas, Steven Kapan, Lipirin Palangat, James Kapia, na planti Ailan Son pilaia i stap bilong strongim tim. Olsem na Muruks bai win sapos sampela tim i

pilai kaskas long em.

Eremas bai lukautim fulbek posisen na traim long bringim bal i go long mak bilong birua tim ol taim. Na Bernard Bate bai i go pas long lukautim ol arapela boi long gem. Bate i gutpela long stiam. Olsem na em bai go pas long toktok na strongim ol boi long pilai gut. Sapos tupela i lukluk long wok bilong tupela, narapela tupela smok balus olsem James Kapia na Lipirin Palangat bai pinisim hatwok bilong tupela long skoarim moa trai.

Dispela Sande i luk olsem kosa David Tantu bai mekim sampela liklik senis long beklain. Bikos i gat sampela pilaia i no gutpela yet long sisen prop resis.

Tantu i tok Martin Balbal bai helpim Vincent Baul, husat i senisim Rudolf Wanwanu. Na Ezekiel bai ran long seken rowa posisen. Bikos tupela pilaia i bin bagarap.

Long pies bilong skram em ainman bilong PNG Kumul, Steven Kapan wantaim Martin Ingrin bai i go pas long lukautim. Tupela bai kisim helpim long Terry Kalang FM Longbut na Herman Patia long seken row posisen.

Ilam i tok em i gat bikpela bilip long dispela lain ap. Na sapos kepten Bate wantaim Eremas na tupela winga Palangat na Kapia i pilai gut long posisen bilong ol, Muruks bai winim namba tu gem long Sande.

Tasol ol i mas lukaut tu long ol boi Goroka. Goroka Royals i bin nekim Kainantu Hawks 34-4. Dispela i soim olsem Goroka i gat laik tu long winim Cambridge Kap taitel. Olsem na em bai yusim olgeta strong na ol liklik stail bilong winim Muruks.

## Ol soldia boi mas senisim stail

PRIMIA tim bilong Mosbi, Difens i gat bikpela laik long winim gren fainal bilong Cambridge Kap resis. Long dispela as na em i nekim Kerema Kouri 42-8 las Sande long resis bilong namba wan raun.

Dispela Sande ol soldia boi bai bungim Tabubil Royals long Tabubil. Na i luk olsem Difens bai mekim wankain samting. Tasol Difens i mas senisim stail na gem plen bilong em. Ol boi husat i pilai long las wik i no soim gutpela gem. Olsem na ol i mas senisim stail bilong ol bipo ol i bungim Tabubil Royals.

Las Sande 16 klap olgeta i bin resis. Tasol 8-pela i lus long namba wan raun. Na dispela wik 8-pela tim tasol bai i go insait long namba tu raun.

Difens i gat bikpela laik longwinim gen Kap. Nau yet ol pilaia i no pilai gut. I luk olsem ol pilaia i mas stretim ol yet hariap bipo long Sande. Sapos ol i pilai wankain raitis gem olsem long

## Sapos ol i laik holim pasim yet klap

las wik, Tabubil Royals bai tanim tebol long ol.

Las wik sampela pilaia i malolo. Tasol ol boi husat i stap long fil i pilai gut na winim dispela gem long bikpela skoa. Olpela Kumul winga, Arnold Krewanty i pilai tu. Em pilai gut na sapatim narapela winga James Miviri, fulbek Joe Uvilime, prop Kera Ngafin, seken rowa na kepten Kes Paglipari na huka Ronald Vue.

Dispela em i wanpela stail bilong Difens tasol, ol boi i mekim planti rong insait long fil. Difence i mas senisim kain stail sapos em i laik win. Nelson John, Simon Patimos, John Mukale, Lahui Ako na Billy Seove i no kamap long fil. Tasol dispela Sande kosa Gaius Kula i mas tingting gut long lain ap bilong em.

Lukluk bilong *Ragbi Lig Nius (RLN)* long

pilai bilong Difens las wik, i luk olsem stended bilong gem i stap aninit long 60 pesen long kain nesanel gem olsem Cambridge Kap. Sapos Difens i gat bikpela laik longwinim gren fainal, stended bilong gem i mas stap long 75 na 100 pesen.

Difens i mas winim liklik senta olsem Kerema na Tabubil long bikpela skoa. Dispela bai givim gutpela piksa long ol arapela senta olsem ol soldia boi long siti i gat bikpela tingting long holim pasim Cambridge Kap i stap long Mosbi long namba tu taim.

Nau yet kepten Paglipari i gat bikpela bilip olsem Difens bai winim yet Tabubil Royals. Na bungim narapela strongpela tim long semi fainal long painimaut husat bai i go insait long gren fainal long Sande Oktoba 10.



**Kas bilong Vue** • Huka bilong Mosbi Difens, Ronald Vue sisti i go antap long eria bilong Kerema Kouri wantaim bal. Kouri pilaia long baksait i painim hat long takellm em.

## Tabubil Royals lus long tupela poin tasol egensim Kiunga South

i kam long pes 2 Souths. Tasol Souths i no givim liklik sans long ol. Skoa i stap i stap olsem 12-4 i go inap haptaim.

Bihain long hap taim, kosa bilong Royals Cornell Daipo i skulim ol boi bilong em gen

long senisim gem plen. Na tu long sanapim strongpela difens. Long dispela as ol plisman i stapim olgeta liklik sans bilong Souths long putim trai long seken hap. Faipela minit i lusim

stat bilong seken hap na kepten bilong Royals Poling Miti ran abrusim tupela pilaia long putim fes trai bihain long hap taim. Prop Ita Kuna i kikim konvesen na bringim skoa i go antap 10-12. Dispela i bringim olgeta

tingting bilong ol plisman long pilai strong na winim Souths.

Olsem na Royals i putim strongpela gem long stapim ol pilai bilong Souths i go insait long mak bilong em.

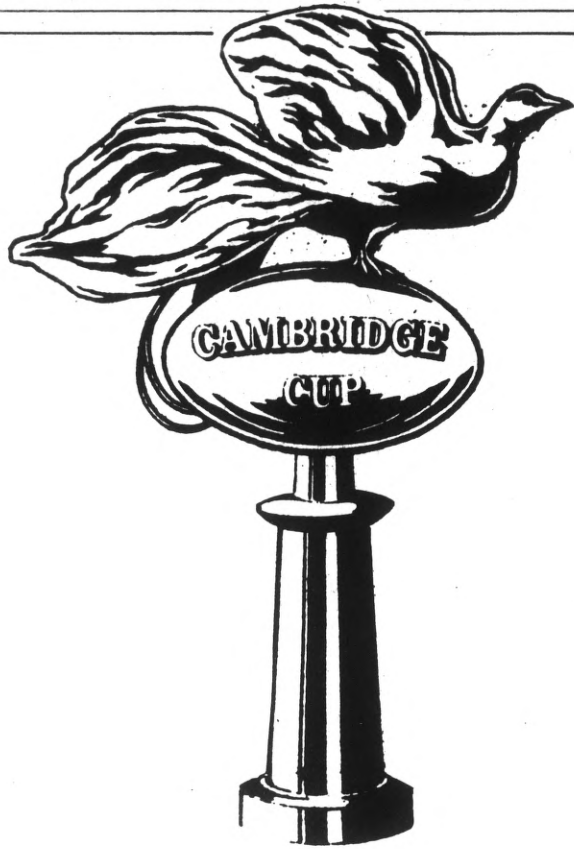

• Arnold Krewanty bilong Mosbi Difens i holim pasim stret nek bilong Kerema Kouri pilala las Sande long Lloyd Robson oval, Mosbi. Senta Jack Uradok long lephan sambai tasol long helpim Krewanty. Difens i win 42-8.

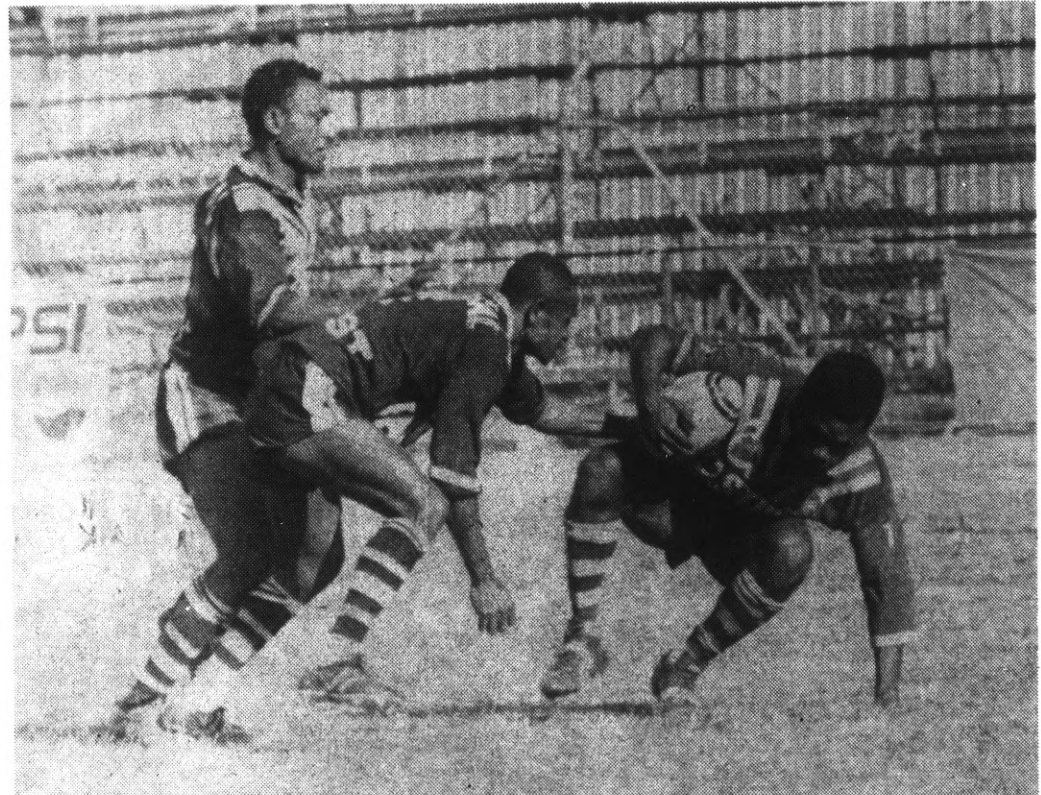

• Clement Mirisa bilong Difens i pundaun hariap wantaim bal egens tupela Kerema Kouri pilala.

**1992 CAMBRIDGE KAP TONAMEN**

**Skoa bilong Raun 1:**

Mosbi Difens	def	Kerema Kouri	42-8
Madang Royals	def	Wewak Royals	26-12
Goroka Royals	def	Kainantu Hawks	34-4
Rabaul Muruks	def	Kimbe Norths	52-0
Lae Spiders	def	Wau/Bulolo Brothers	24-14
Hagen Hawks	def	Kundiawa Tigers	24-22
Kiunga Souths	def	Kiunga Souths	14-12
Mendi Bulldogs	def	Wabeg Tarangau	10-8

**Raun 2 Dro:**

**SANDE 27 SEPTEMBER**

	Pilai	Senta
Lae Spiders	vs	Madang Royals (Lae)
Rabaul Muruks	vs	Goroka Royals (Rabaul)
Mendi Bulldogs	vs	Hagen Hawks (Mendi)
Tabubil Royals	vs	Mosbi Difens (Tabubil)

**1992 CAMBRIDGE KAP TONAMEN**

16 tim bilong pilai:

1. Mosbi Difens
2. Kerema Kouri
3. Tabubil Royals
4. Kiunga Souths
5. Lae Spiders
6. Wau/Bulolo Brothers
7. Madang Royals
8. Wewak Royals
9. Rabaul Muruks
10. Kimbe Norths
11. Goroka Royals
12. Kainantu Hawks
13. Hagen Hawks
14. Kundiawa Tigers
15. Mendi Bulldogs
16. Wabeg Tarangau



• Tabubil Royals.



• (ANTAP) - Kerema Kouri pilala lusim bal long strongpela takel bilong Jack Uradok bilong Mosbi Difens. Tupela tim ya i bin bung long namba wan raun bilong Cambridge Kap resis las Sande long Mosbi, na Difens i win 42-8. Poto Ian Kakarere.

• (LEPHAN) - Oi bagaros bilong Kiunga Souths i sambai bipo oi i go daun long Tabubil Royals 14-12 long namba wan raun bilong 1992 Cambridge Kap tonamen las Sande long Kiunga.



# THE BIG ONE



**CAMBRIDGE CUP**  
**P.N.G. Big League**

**LAE GREN FAINEL POTO:**



• Pilaia bilong Spiders bungim strongpela takel bilong wanpela Tarangau pilaia.



• Tupela Spiders pilaia i mekim dai stret long wanpela Tarangau pilaia long graun long Lae Ragbi Oval. Ating long kain strongpela takel olsem na ol i win.



• Spiders pilaia i pilim pen liklik long het na haitim long han.



• Fowat pilaia bilong Tarangau i pasim al na ran wantaim olgeta strong. Tasol em wantaim ol wan pilaia bilong em i no pilai strong moa na i lus 16-6.



• Ol Spiders pilaia i stap long olgeta hap na banisim dispela Tarangau pilaia long autim bal.



• Tupela Wes pilaia i holim pasim wanpela Tarangau pilaia long graun.

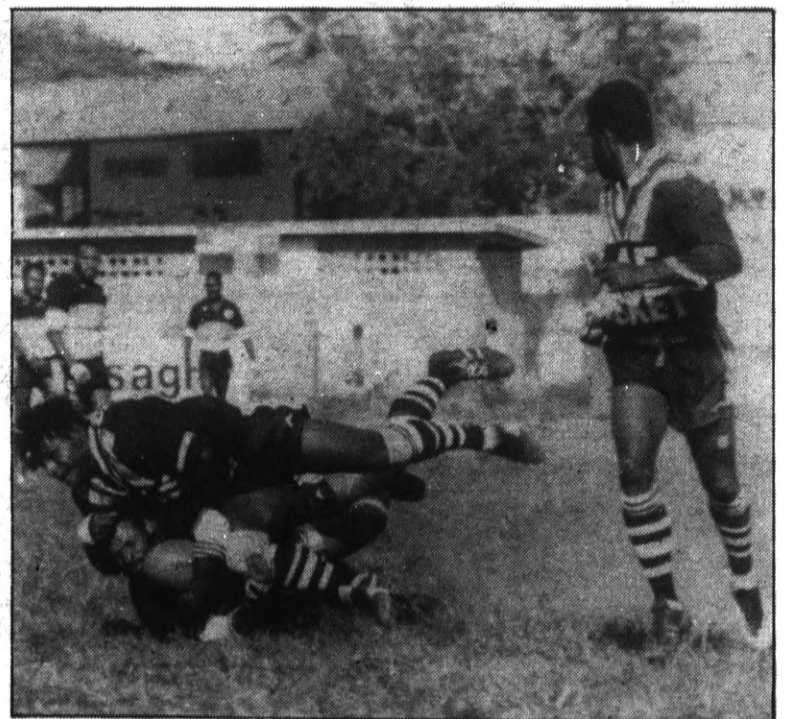

• (ANTAP) - Spiders pilaia i antapim stret wanpela trangu pilaia bilong Tarangau. Narapela Spiders pilaia long raithan i lukim olsem wan pilaia i winim pinis takel. Olsem na em i lukiuk tasol na ran i go bek long banisim trai lain.

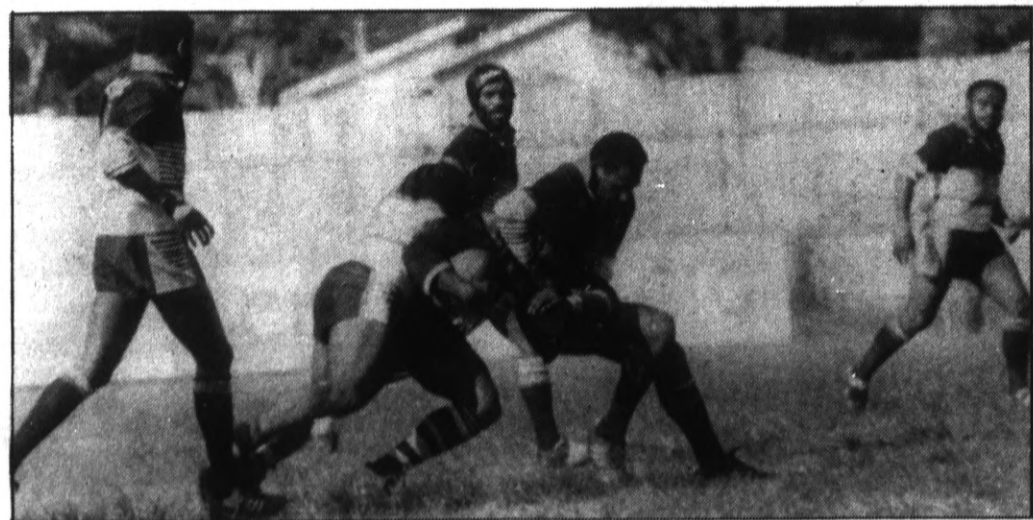

• (LEPHAN) - Pilaia bilong Tarangau i laik brukim stret nek bilong Spiders pilaia. Tasol kain strongpela salens i no stapim Spiders long pala moa. Olsem na ol i winim 1992 Lae Winfield Kap wantaim stall. Kas bilong ol yet. *Ol poto Sape Metta.*

**Wewak lig  
painim yet  
mani bilong  
mema long  
PNGRFL**

# Kas bilong ol boi Is Taraka

WEWAK lig i painim yet mani bilong mema gen long mama bodi long 1993 sisen.

Fi bilong mema em K3,000.

Seketeri Aga Vele i tok lig i painim yet mani bilong mema gen long Papua Niugini Ragbi Futbal Lig (PNGRFL).

Wewak taun i no olsem ol arapela bikpela senta bai i gat planti praiwet kampani, we lig na 4-pela mema klap bilong en i kisim helpim long sponsasip.

Ol mema klap bilong lig em Royals, Country, Tarangau na Tigers. Ol i gat wanwan tim long 4-pela divisen. Dispela em long Anda 17, Anda 19, A Risev na A gret.

Mista Vele i tok hevi bilong bungim inap mani em i wanpela bikpela hevi bilong Wewak lig.

Vele i askim tu sampela bikman bilong Wewak long givim sampela helpim.

I gat sampela gutpela helpim long mema long mama bodi. Bikos ol ol pilaia i ken pilai long ol nesanel resis olsem son trails na Cambridge Kap tonamen.

Las Sande primia tim Wewak Royals i go go daun long Madang Royals 26-12 long Ron Albert Oval.

Dispela sisen Wewak i salim wanpela tim long Noten Son trails. Na tupela pilaia bilong em, Julius Taliu na Nelson Nilkare i bin stap insait long Noten Son tim egens Gret Briten Lions.

Vele i tok sapos ol bikman i givim helpim, dispela bai i gutpela tru. Long wanem dispela bai apim tingting na laik bilong ol pilaia. Long wanem ol i save olsem ol i ken pilai nau long ol nesanel resis bilong PNGRFL, na soim stail bilong ol.

Seketeri vele i tok sampela taim long mun Oktoba, bikpela kibung (AGM) bai i kamap. Insait long dispela kibung bai ol i makim ol nupela eksekutiv bilong lig.

Presiden Joe Mande na eksekutiv bilong em i bin holim opis long 1991 na 1992 sisen.

Insait long AGM, ol bai vot long ol nupela eksekutiv bilong 1993 na 1994 sisen.

SPIDERS em sempion klap nau bilong Lae Winfield Lig.

Ol stail boi bilong Is Taraka winim dispela nem bihain long ol i daunim strongpela salens bilong Tarangau 16-6. Planti tausen manmeri i bin kamap long Lae Ragbi Oval na lukim dispela bikpela gem long Sande Septemba 13.

Ol boi Is Taraka i winim tu K1,400 prais mani wantaim Winfield Kap.

Bihain long namba wan hap bilong pilai, tupela tim i dro 6-6.

Long namba tu hap bilong pilai, Spiders i skoarim tupela trai we kik bilong tupela gol long wanpela trai karim kaikai. Spiders i banisim gut tu Tarangau long skoa long namba tu hap.

Long stat bilong pilai, tupela tim wantaim i sanap strong na banisim trai bilong tupela. Olsem na nogat wanpela trai i kamap long 10-pela minit i go insait long pilai.

Spiders i brukim kiau long 12 minit taim John Bob i kisim wanpela gutpela bal i kam long wan pialia, na skoa long kona. Jacob Danny i sanapim gut bal, na kikim tupela poin.

Dispela trai i pusim Spiders i go pas long skoa 6-0.

Tasol Tarangau i bekim long 17 minit faiv eit Pater Malagian i skoa aninit long tupela gol pos. Em yet i kikim kik bilong tupela poin, na tupela tim i pas long skoa 6-6.

Bihain long dispela, ol pilaia bilong tupela tim wantaim i traim olgeta trik bilong winim gem o skoa moa. Tasol banis bilong tupela i sanap strong wantaim ol gutpela takel. Olsem na tupela i bin pas long skoa 6-6 inap hap taim.

Long namba tu hap bilong pilai, ol Spiders pilaia i go insait long fil wantaim strongpela tingting stret long win. Tasol ol i no skoa liklik inap long 58 minit bilong pilai.

John Bob i skoa gen. Kik bilong tupela poin i karim kaikai na Spiders i go pas gen long skoa 12-6.

Tupela minit bipo long ful taim, Spiders i skoarim wanpela moa trai long kona tru bilong fil. Winga Andrew Gee i skoarim dispela trai.

Kik bilong tupela poin i no kamap. Bikos ol sapota ran i go insait hariap long fil long amamasim ol pilaia.

Long gem bilong ol arapela gret, Difens i winim Tarangau 24-18 long risev gret, na Spiders i wilwilim Royals 21-8 long gren fainal bilong Anda 19 divisen.

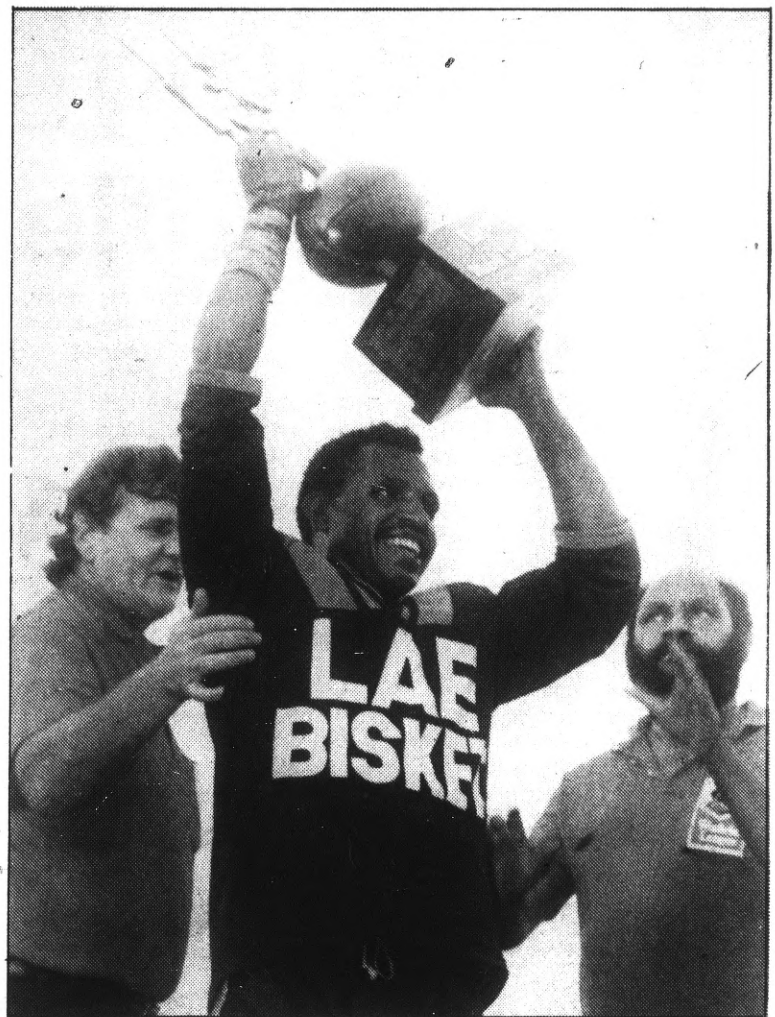

• Kepten bilong Spiders i apim Winfield Kap tropi bihan long ol i autim Tarangau 16-6 long gren fainal bilong Lae Winfield Lig. Poto Sape Metta.

## Kuri go pas long Hawks

### STORI BILONG PILAIA:

**Nem:** Kaneo Kuri  
**Krismas:** 17  
**Posisen:** Fulbek  
**Klap:** Hawks  
**Lig:** Morobe Kantri Lig  
**Provins:** Isten Hailans

**KURI i bin stap pilai ragbi lig wantaim**

**Hawks ragbi lig klap bilong Morobe Kantri lig long 1991 sisen.**

**Long sem yia yet ol i pilai i go insait long gren fainal egens Souths. Dispela i bin namba wan taim stret bilong yangpela boi**



• Kuri ... bungim namba tu gren fainal

Isten Hailans ya long pilai long gren fainal bilong wanpela bikpela spot em i save mangalim stret long laip bilong em, olsem ol arapela yangpela man.

Yangpela Kuri i go pas gut tru long tim bilong em na ol i daunim strongpela Souths tim 6-2, na autim primia taitel bilong Morobe Kantri lig.

Bihain long dispela gren fainal, Kuri i luk-save long wanem kain ol salens i save kamap long gren fainal. Na tu em i lainim sampela gutpela stail na rot bilong daunim ol stronpela salens em birua tim i givim oltaim long ful 80 minit.

Dispela sisen, Kuri wantaim ol wan pilaia i strongim stail bilong ol long win. Na kisim Hawks i go insait gen long gren fainal egens sem birua tim bilong las yia, Souths.

Gren fainal bai kamap long dispela wiken.

Dispela bai i namba tu gren fainal grem bilong boi Isten Hailans.

Kuri i gat bikpela bilip olsem em bai i go pas gen na helpim ol boi bilong em long daunim Souths long namba tu taim.

## Ol plisman long Wewak salim kaikai long Madang

BARBARA TOMI i raitim

WEWAK Royals na Madang Royals i bin pilai wanpela strongpela gem stret las Sande long Ron Abert Oval, Madang.

Ol pilaia bilong tupela tim wantaim i pilai gut tru. Na tu i sanapim strongpela banis long tra! lain. Mekim na nogat skoa i bin kamap inap long 35 minit.

Eric Mamane bilong Madang i setim namba wan trai bihain long em i givim wanpela gutpela bal long Keai Haive. Mekim na Madang Royals i go pas long skoa 4-0 inap hap taim.

Long namba tu hap bilong pilai, strong fowat bilong Madang, Konoba Poiye i skoarim wanpela trai em kik bilong tupela poin i no karim kaikai. Dispela i pusim Madang i go pas moa long skoa 8-0.

I no longtaim wanpela Wewak pilaia i pundaun bal. Willie Martia

bilong Madang kisim dispela bal na salim Otto Bani long beklain i go skoa.

Dispela trai pusim Madang i go pas moa long skoa 12-0.

Ol plisman bilong Wewak i lukim olsem ol i nogat inap taim nau. Onga Koke lukim olsem na skoarim wanpela trai.

Steven Aua kikim gut kik bilong tupela poin na Wewak i ran bihain 12-6.

I no longtaim Paul Gonopa i skoarim narapela trai gen. Wewak i ran klostu nau long Madang 16-10.

Tasol Anton Michael kikim wanpela fil gol bilong Madang, na ol i go pas moa 17-10.

John Goiye skoarim wanpela moa trai na Madang i win 21-10.

Ol pilaia i skoa em: Madang Royals - Kela Haive, Konoba Poiye, Otto Bani, Willie Marita (trai), Anton Michael (fil gol). Wewak Royals - Onga Koke, Paul Gonopa (trai), Steven Aua (konvesen kik).

## Balamus kliam ol paul toktok

i kam long pes 8

long tupela lig, na i no Air Niugini RLC i ogenaisim. "Taim i sot tasol na mipela i kisim dispela sans."

Planti klap opisal tu i gat tingting nau olsem Balamus i plenim long kisim dispela 6-pela pilaia long joinim Air Niugini long 1993 sisen. Olsem na em i laik amamasim ol long go long Taunsvil.

Tasol Balamus i bekim olsem dispela em ol rong tingting. "Wanem samting mi mekim em long bihainim tasol askim na kondisen bilong Taunsvil lig wantaim PNGRFL," em i tok.

Ful tim bilong go pilai em Larry Saea, Duffy Mase, David Mune,

Wardmen Bernard, Steven Manas, Johnson Tia, Rex Hapeo, Joe Giske, Mark Agi, Arua Ben Moide, Duffy Ben Moide, Aisame Mihare (Air Niugini), Michael Toivita, Tuksy Karu, Joshua Kouoru (wes), Peter Yuwi (Souths), Weka Lae (Royals) na Elias Paiyo (Tarangau).

Tim bai lusim Mosbi long Oktoba 2 aninit long nem, Air Niugini Presiden Invitesen XIII. Na bai yusim yunifom bilong Air Niugini.

Namba wan askim i bin kam long 25 pilaia tasol. Tasol klostu long taim bilong krismas na Air Niugini kampani givim 20 fri sia tasol bilong balus long i go na i kam.

# Lukaut long banisim Alfie

BOS bilong Brisbane Broncos John Ribot i salim tok i go long kosa bilong St George Brian Smith long ol birua bilong banisim gut Tes hap bek Allan Langer long gren fainal bilong Sande.

Langer i winim wanpela top awot bilong 1992 sisen ol i kolim Rothmans Medal.

Ribot em olpela Tes winga bilong Australia.

"Mi kalap nogut long harim ol klap i tok ol bai banisim gut tru olgeta kona bilong Alfie long gren fainal. Dispela bai i hat tru.

"Planti pipel i bin traim long mekim olgeta long 5-pela yia olgeta. Na wanem samting ol i mekim em givim spes long ol arapela pilaia, bikos olgeta i kam karakum long banisim wanpela pilaia tasol," em i tok.

Sief eksekutiv bilong St George Geoff Carr i mekim wankain toktok olsem.

"Mi no wanpela i ken senisim stail long banisim wantaim pilaia tasol olsem Langer long fil," Carr i tok.

"Dispela em gem bilong 13 pilaia

egens 13 pilaia. Gutpela samting long dispela em mipela i gat strongpela banisim tru. Dispela i kamap klia long tupela wik i go pinis."

Ribot i tok Brisbane i stat paia bihain long priliminari fainal egens Illawarra, na ol i win.

"Em i no olsem mipela i no traim hat long win o lukautim pilai long fil. Mipela i stap long fil tasol mipela i no bungim gut pilai.

"I gat sampela biknem ekspirien pilaia, na olsem wanpela tim, i gat sampela pilaia husat i no bin pilai long semi fainal bipo.

Ol semi fainal i narapela kain. Bikos salens yu bungim i bilong sotpela taim tasol. Mipela i kam long 22 wik nau. Na ol pilaia i save olsem em i mani wik bilong sisen," em i tok.

"Taim yu gat ol lain olsem Allan Langer, Glen Lazarus, Renouf na sampela moa, wanpela bilong ol bai helpim tim long ol trik bilong em.

"Mipela i save wetim dispela tasol long kamap, na bihain putim moa nil antap long bokis bilong daiman," Ribot i tok.

*Telegraph Mirror*

## Balamus klian ol paul toktok

PLANTI pilaia bilong Air Niugini RLC bilong Mosbi i no amamas long presiden Immanuel Balamus long kism 6-pela pilaia bilong ol arapela klap bilong Mosbi Winfield Lig long go pilai primia tim bilong Taunsvil.

Dispela em long Coca Cola Salens, long gem bikpela gem namel long St George bilong Sidni lig, na wanpela Not Kwinslen Invitesen sait.

Save i stap olsem Not Kwinslen bai kism tupela top pilaia bilong Papua Niugini, Kumul fulbek Philip Boge na winga Kini Tani.

Sampela sinia na junia pilaia i tok ol pilaia bilong Air Niugini tasol i mas go pilai long Taunsvil.

Ol pilaia Balamus yet i kism em Tuksy Karu, Joshua Kouoru, Michael Toivita (Wes), Peter Yuwi (Souths), Weka Lae (Royals), na Elias Paiyo (Tarangau).

Ol pilaia i tok sapos pilaia bilong ol arapela klap i stap insait long tim orait, Mosbi lig i mas putim sampela mani i kam insait long helpim Air Niugini RLC.

"Dispela em ol i daunim tru bilip bilong sampela Air Niugini pilaia husat i mas go long dispela trip (This is a slap on the face of some Air Niugini players who deserve to go on that trip)", em i tok.

Presiden Balamus i bekim olsem dispela em ol rong tingting olgeta.

Em i tok Taunsvil lig i bin salim wanpela askim i kam long Air Niugini RLC long salim wanpela tim, bikos em i bin go pas long resis na i gat bikpela sans long winim gren fainal. Tasol ol boi i no go insait long gren fainal. Olsem na klap i givim dispela askim i go long PNGRFL long painim arapela tim. Bikos Taunsvil lig i laikim primia tim long go daun pila egens primia tim bilong ol, Brothers husat i winim primia taitel long 4-pela sisen nau. Wina bai kism 4,000 Australian dola prais mani.

Orait PNGRFL i bin askim Mosbi Winfield Lig long salim Mosbi Vipers. Ol paitim toktok i go i kam na lukim olsem ol i nogat inap taim long mekim wok rere long salim Vipers.

Olsem na PNGRFL tromoi dispela askim i kam bek long Air Niugini.

Taunsvil lig i harim olsem na laikim 8-pela pilaia bilong ol arapela klap long stap insait tu long Air Niugini tim. "Mi tingting long ol boi bilong mi na givim ol sampela kondisen. Olsem na mi katim namba bilong ol pilaia long ausait i go daun long 6-pela," em i tok.

Presiden i tok em i traim long putim wantaim wanpela tim. Na i no laikim pasin bilong kism wanpela tim i go daun, na lus. Em i tok tu olsem dispela invitesen o askim i stap namel

*i go moa long pes 7*



# CAMBRIDGE CUP

## P.N.G. Big League



# SPAK MAIK



**EMS** EXPRESS MAIL SERVICE

**Reliable, Affordable, Speed**

..... and that's the success of our business

Contact Willie or Rose on 27 4449/ 27 4321



Post & Telecom

# REBO



NAU REBO PINISIM TOKTOK ...

**KIUNGA WIN! WIN! TASOL!**

TAIM BILONG FLAI NA OL I GO KALAP LONG BALUS NA TEK-OFF I GO LONG MOSBI ...

OL I KAM KAMAP LONG MOSBI ... REBO WUKLUK I GO AUT LONG KINIDUA NA TINGTING LONG TAIM BIPO EM I STAP HIA ...

HAA, MOSBI! LONG TAIM NO SI! NAU MI MAN KIUNGA ... MI KAM LONG SALENSIM YUPELA!

OL PUNDAUN LONG RAN-WE BILONG TALAIR, NAU OL I KISIM TEKSI NA SUT I GO LONG GRANVIL MOTEL ...

MIPELA OL LAIN BILONG KIUNGA RAGBI LIG ... NA MIPELA I KAM SEK-IN LONG 8-PELA RUM BILONG MIPELA ... 3-DE TASOL!

OH, YES! MIPELA WETIM YUPELA ... RUM BILONG YUPELA I RED!

KIUNGA

NEKS DE LONG TRAIPELA MONING REBO KIRADIM OL BOIS NA OL I RON I GO LONG JEKSON PLES BALUS NA KAM BEK ...

OKE, BOIS! LAS EKSASIS BILONG YUMI ... YUMI RON I GO LONG PLES BALUS NA KAM BEK NA BREKAS!

HEY? PLES BALUS WE ... MI NO SAVE YA!

ESH! YUMI BIHAINIM KOSA TASOL!

NAU LONG BIKPELA DE OL I BIN WET LONG EN ... OL I HARIM BAS BILONG GRANVIL MOTEL NA OL I GO LONG P.R.L. LONG PILAI ...

YUMI GO NA SAROTIM OL ...

HEY, OL KIUNGA TAIM IGO INSAIT NALI!

**Yu save tu olsem long olgeta wan wan wok em i kamap insait long Maining na Petroleum Industri i save gat narapela tupela wok i kamap long ol lain husat i givim ol sevis samting i go long ol dispela projek o no gat?**



Dispela tok save i kam long:  
**THE PNG CHAMBER OF MINES AND PETROLEUM**  
 P.O. Box 1032, Port Moresby, Phone: 21 2988 Fax: 21 7107

# Musik TELEVISION Komik

## Muvi mas bihainim stori bilong singsing

I NO gat bikpela senis tumas i kamap long ol ples bilong ol singsing long las wik.  
Wanpela tasol em long singsing bilong Vincent Pia, *Iwarwatut* we i pundaun long namba tri ples i go long namba 5. Tupela singsing bilong Junia Kopex ben, *Kulungi* na *Yu Tasol* i holim yet namba wan na tu ples. Bihain long ol em singsing bilong

Leonard, *Meri Nipsco*.  
Long dispela wik i gat wanpela singsing i luslain long PNG Top 20 na narapela i kam insait kisim ples bilong en. Singsing we i luslain nau em *Iso Tofo Be* bilong ol lain Voice In The Wind gospel grup bilong Popondetta long Oro provins. Na singsing husat i kam insait kisim ples bilong en nau em *Adisena* bilong David Kurni.

Kain musik na danis bilong *Adisena* i gutpela. Bikos em i kamap tu long televisen na planti sapota bilong musik i laikim. Tasol dispela ol lain i laikim bikos tok ples insait long dispela singsing i no klia long ol. Olsem wanem long ol lain husat i klia na save long tok ples?

Ol i kisim dispela singsing long tok ples Ewage bilong ol lain long nambis.

Long tok ples bilong ol dispela lain, singsing *Adisena* i min olsem "Mi Laik Wokim".

Sampela bilong ol i tok ol toktok insait long dispela singsing i no pinis gut. Pastaim long em i go long namba wan hap bilong singsing, i mas gat hap bilong tokaut long wanem samting tru bilong mekim.

Long tok ples Ewage, ol i save yusim dispela singsing long taim bilong marit. Wanpela man bai kirap na singsing na toktok long marit.

Wankain ripot tu i bin kamap long singsing *Tutu Areng* bilong Henry Kuskus. Ol ripot i tok dispela em i singsing bilong wari tasol long taim bilong wokim musik muvi bilong en, ol yangpela i hatim danis na brukim bun nabaut.

Narapela gen em singsing *Malamsa Wauma Sawauma* bilong Dark Ends long Busiga long Morobe provins. Na dispela em i wanpela singsing Sabic bilong ol tumbuna long bipo yet i kam inap nau.

THURSDAY - 24TH SEPTEMBER, 1992

6.27	STATION OPEN
6.30	ITN NEWS
7.00	TODAY SHOW (G)
8.58	EMTV TOKSAVE
9.00	STATION CLOSE
1.10	STATION RE-OPEN
1.12	EM-TV TOK SAVE
1.15	MIDDAY SHOW
	WITH RAY MARTIN (PGR)
2.30	SESAME STREET (G)
3.30	KIDS KONA
	FAT CAT (G)
4.00	QUICK DRAW McGRAW
4.30	THE JETSONS (G)
5.00	BEWITCHED
5.27	EMTV TOK SAVE
5.29	EMTV NEWS BREAK
5.30	HOME AND AWAY (G)
6.00	NATIONAL EMTV NEWS
6.30	A CURRENT AFFAIR
7.00	SALE OF THE CENTURY
7.25	CHIN H MEEN SUPER-SOUND NEW RELEASE
7.30	NEIGHBOURS (G)
8.00	THE COSBY SHOW:
8.27	RUGBY UNION ROUND UP
8.30	ALL TOGETHER NOW: "Your're So Vain"
9.00	THE GOLDEN GIRLS: MARRIED WITH (PGR)
9.30	CHILDREN: BURKE'S BACKYARD (G)
10.00	10.55 CHIN H MEEN SUPER-SOUND NEW RELEASE
11.00	HAWAII 5-0 (PGR)
00.00	NATIONAL EMTV NEWS
00.27	REPLAY: MEDITATION WITH PASTOR WALO ARNI
00.30	STATION CLOSE
	FRIDAY 25TH SEPTEMBER, 1992
6.27	STATION OPEN
6.30	ITN NEWS (G)
7.00	TODAY SHOW (G)
8.58	EMTV TOK SAVE
9.00	STATION CLOSE

## EMTV

1.04	STATION RE-OPEN
1.07	CHIN H MEEN SUPER-SOUND NEW RELEASE
	EMTV TOKSAVE
1.12	MIDDAY SHOW (PGR)
1.15	SESAME STREET (G)
3.30	KIDS KONA
	FAT CAT (G)
4.00	QUICK DRAW McGRAW
4.30	THE JETSONS (G)
5.00	BEWITCHED (G)
5.27	EMTV TOK SAVE
5.29	EMTV NEWS BREAK
5.30	HOME & AWAY (G)
6.00	NATIONAL EMTV NEWS
6.30	A CURRENT AFFAIR (G)
7.00	SALE OF THE CENTURY
7.25	CHIN H MEEN SUPER-SOUND NEW RELEASE
7.30	NEIGHBOURS (G)
7.55	NCDC NEWS
8.00	HEY DAD (G)
8.57	EMTV TOK SAVE
9.00	FRIDAY NIGHT (MAO)
	MOVIE: "The Deer Hunter"
11.00	BONANZA: "Dead Wrong" (G)
11.30	NATIONAL EMTV NEWS
	REPLAY
11.57	MEDITATION WITH PASTOR WALO ARNI
00.00	STATION CLOSE
	SATURDAY 26TH SEPTEMBER, 1992
10.27	STATION OPEN
10.30	SKY ROCK (G)
12.00	To be advised (G)
12.30	GILLETTE (G)
1.00	WIDE WORLD OF SPORTS (G)
2.00	AFL GRAND FINAL
4.55	CHINE H MEEN

## SUPERSOUND NEW RELEASE

5.00	BEYOND 2000 (PGR)
6.00	NATIONAL EMTV NEWS
6.30	HEY HEY IT'S (G)
8.30	AUSTRALIA'S FUNNIEST HOME VIDEO (G)
9.00	JAKE AND THE FATMAN: (PGR)
10.00	MTV MAO
00.00	NATIONAL EMTV NEWS
	Replay
00.27	MEDITATION WITH PASTOR WALO ARNI
00.30	STATION CLOSE
	SUNDAY 27TH SEPTEMBER, 1992
9.52	STATION OPEN
8.55	CHIN H MEEN SUPER-SOUND NEW RELEASE
9.00	HEINEKEN'S FACINATING ART (G)
10.00	WINFIELD LEAGUE
2.00	WINFIELD CUP - GRAND FINAL
5.00	WINFIELD LEAGUE
	Continues ..... (G)
6.00	NATIONAL EMTV NEWS
6.30	WONDERFUL WORLD OF DISNEY "Diamonds On Wheels" (Part III) (G)
7.30	60 MINUTES (G)
8.30	CHIT CHAT WITH SIR PAULIAS MATANE
8.35	SUNDAY NIGHT (PGR)
	MOVIE: "The Jazz Singer"
10.30	GUNSMOKE (G)
11.30	NATIONAL EMTV NEWS
	REPLAY
00.00	PORTUGESE FORMULA 1 GRAND PRIX
01.57	MEDITATION WITH PASTOR WALO ARNI
02.00	STATION CLOSE

## PNG TOP 20 AS AT 12/09/92

NO.	SONG	ARTIST
1 (1)	<i>Kulungi</i>	JR Kopex
2 (2)	<i>Yu Tasol</i>	JR Kopex
3 (4)	<i>Meri Nipsco</i>	Leonard
4 (5)	<i>Lonely Makuri</i>	Basil Greg
5 (3)	<i>Iwarwatut</i>	Vincent Pia
6 (6)	<i>Aiyo Aiyo</i>	Barike
7 (7)	<i>Sori Pisup</i>	Henry Kuskus
8 (9)	<i>You Are The King</i>	Voice In The Wind
9 (8)	<i>Milne Bay</i>	Hollie Maea
10 (12)	<i>Meri Samarai</i>	PS Duet
11 (11)	<i>Wan Kantri</i>	Barike
12 (13)	<i>Goi Vavine</i>	Helgas
13 (16)	<i>Lau Les</i>	Leonard
14 (0)	<i>Adisena</i>	David Kurni
15 (10)	<i>A Vutung</i>	Erex Suisui
16 (17)	<i>Harim Karai</i>	Navigators
17 (18)	<i>Pipia Man</i>	City Hikers
18 (19)	<i>Kerema</i>	PF Company
19 (20)	<i>Kake IB Car</i>	Simon Tazzi
20 (14)	<i>Nambis</i>	Henry Kuskus

• Ratings based on requests on Radio Kalang and not cassette sales.

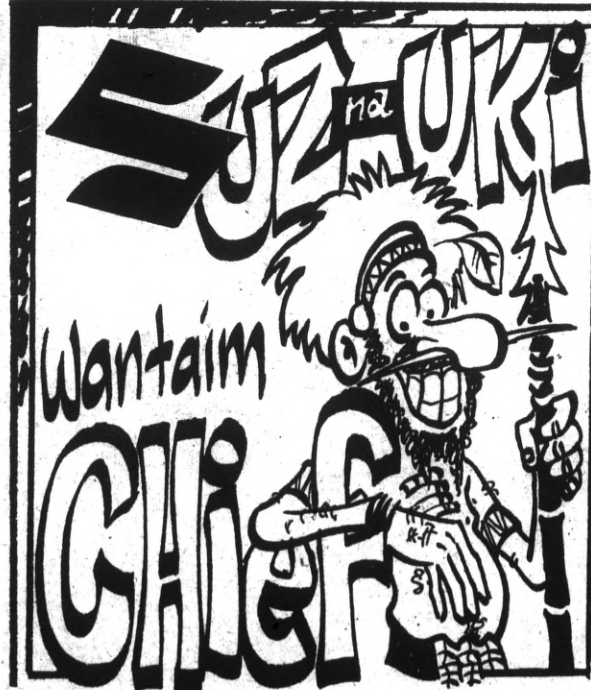

# WARNING!!

A man gets up in the morning washes himself with advertised soap, shaves with advertised foam & razor, brushes his teeth with advertised toothpaste, puts on his advertised designer label clothing, drives into work in his new advertised car, arrives and switches off his advertised burglar alarm, turns on his advertised till and waits for people to shop with him.

He receives a telephone call from a newspaper and gets them off the phone by saying he doesn't believe in advertising.



QUESTION: Why is it then when his business is close to crumbling he will advertise it for SALE?

ANSWER: **BE WISE AND ADVERTISE**

*Call our advertising department for details of how you can reach thousands of our readers with your MESSAGE.*

## Tel: 25 2500

**WANTOK**

PNG's Tok Pisin newspaper

**THE TIMES**

(11 11 11 11 11 11 11 11 11 11)

PNG's award winning newspaper

PNG  
**BUSINESS**

reporting on the business community

**SPORT**  
*Weekend*

for complete sport coverage



# Wantok

Digitized version made available by



**Copyright:** Under copyright

**Rights Holder:** Word Publishing Company Limited

**Use:** This digital version is made available from the UC San Diego Library under a license granted by the Word Publishing Company Limited. This digital copy of the work is intended to support research, teaching, and private study.

**Constraints:** This work may be protected by copyright law. Use of this work beyond that allowed by the applicable copyright statute requires the written permission of the copyright holder(s). Responsibility for obtaining permissions for any use and distribution of this work rests exclusively with the user and not the UC San Diego Library. Inquiries can be made to the UC San Diego Library program having custody of the work.

**Note on digitized version:** Some of the digital versions presented here reflects the quality and contents of the microfiche. Problems which have been identified include misfiled or out-of-order pages, illegible text; these problems have been rectified whenever possible.