

SSH
Current
Shelves
DU
740
A2
W3
v. 1801

Wantok (Boroko, Papua New
Guinea)
SSH Current Shelves
UC San Diego
Received on: 03-02-09

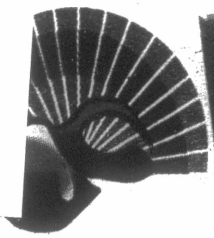

WAI

Gutpela Belo Kaikai



Namba 1801
Wan Wik, Februari 12 - 18, 2009

Niuspepa Bilong Yumi Ol PNG Stret!

K1 tasol
long olgeta hap

BALUS I RON ANTAP



Insait...
Lukim Turis sip Columbus
i kam raun long PNG...
Stori long Pes 21.

PLAI Francis Momo husat i gat 10-pela kras-
mas. Mak plai olsem dispela balus i stap bak-
sa long em. Mostu long bikpela epis bilong Air
Niugini long Mosbi. Dispela balus we i sindaun
antap long tropela pos em i wanpela mak bilong
ples balus long Mosbi na i save pulim ai bilong
plant manmeri.

Poto: Andrew Molen

NCDC tambu long buai

Andrew Molen i raitim

NAU em i tambu long salim buai
long ol pablik hap long Nesanel
Kapitel Distrik (NCD).

Dispela em nupela lo Gavana
bilong NCD, Powes Parkop, i
tokaut long en dispela wik Tunde
long opis bilong em long Mosbi.

Mista Parkop i tokaut long dis-
pela lo sampela wik i go pinis
tasol ol i tokaut stret gen long dis-
pela long Tunde na nau ol wok-
man bilong NCD Komisn (NCDC)
i wok long raun na strongim dis-
pela lo.

Ol i toksave tu long ol manmeri
tu long dispela na askim ol long
harim tok na bihainim.

Astingting bilong dispela lo em
long mekim ples i klin na luk gut-
pela moa long wanem planti ol
hap long Mosbi i pulap long pipia
na spet buai i pas nabaut long
olgeta hap.

Piksa bilong Mista Parkop tu
we i tokim ol manmeri long noken
spetim buai nabaut, em ol i
spetim.

I no olgeta lain i amamas long
dispela nupela lo.

Sampela i kemap long opis
bilong NCDC na toktok strong
olsem dispela lo bai bagarapim
laip bilong ol.

"Prais bilong olgeta samting i
go antap na mipela mas salim
buai na arapela samting long
kisim mani long kaikai," wanpela
meri i tok.

Em i tok, long maket, ol wok-
manmeri i save kisim bikpela
takis mani long ol.

Ol wokman bilong NCDC i rau-
nim Mosbi long Trinde dispela wik
na rausim olgeta manmeri husat i
sindaun na salim buai long ol
pablik hap.

Ol pablik hap em olsem ausait
long ol opis, stua, pablik ples
bilong malolo, bas stop na olsem.

Kain ples olsem Gordons bas
stop em nogat manmeri stret i
raun o sanap long ol ples we i
bipo i save pulap wantaim ol man-
meri i salim buai na kain kain ol
arapela samting.

Mani stap long graun

•Go bek long graun •Wok long graun •Rausim han long poket •Yusim han na kisim mani •Nogat wok, nogat kaikai

Paul Zuvani i raitim

OL manmeri husat i nogat wok
long taun i mas go bek long ples
na wok long graun. Ol manmeri
bilong ples husat i no wok long
graun i mas stat wok nau.

God i givim Papua Niugini (PNG)
planti gutpela samting. I nogat ol
tarangu long PNG. Ol tarangu em

ol manmeri husat i mekim ol yet
stap olsem.

Dispela em toktok bilong Pater
Joseph Sakite SVD, taim em i
givim toktok long ol kalabus man-
meri na wokmanmeri bilong kal-
abus na ol famili bilong ol long
Mosbi long Tunde. Ol i bin bung
long luksave long ol i winim 8-pela
de skul long gutpela sindaun.

"Oltaim mi save tok, nogat wok
nogat kaikai.

"Man i wok em i gat kaikai, man i
no wok em i nogat kaikai," Pater
Joseph i tok.

Pater Joseph i lainim ol kalabus
manmeri na ol wokmanmeri bilong
kalabus na ol famili bilong ol, long
ol rot bilong lukautim na kukim
kaikai.

Em i soim ol manmeri long
mekim pinat bata long pinat, drai
tapioka long tapioka, wel long gris
bilong pik, jinfa na sili paura long
jinfa (kawawar) na sili (lombo), sitor
long jinfa, tomato sos, mins mit
bihain long praim, drai pik mit long
pik mit, gari long drai tapioka na
plawa long drai tapioka.

Moa stori long Pes 3...



Promotim Seif na Strongpela Sosaiti bilong yumi olgeta!





Wantok Niuspepa, the only "Tok Pisin" Niuspepa in Papua New Guinea is seeking the services of a qualified person for the position of

Supplements Reporter

Potential Candidates for the Supplements Reporter Position must meet the following prerequisites:

Qualifications:

- A Diploma or Degree in Journalism;
- At least 5 years experience in reporting for and compiling supplements in the print media;
- A reasonable proficiency in writing news in Tok Pisin;
- Basic knowledge of taking photographs;
- Sound money management ability;
- Be prepared to travel;

Other preferences:

- Valid driver's license;
- Extensive contacts in Business, NGOs and Civil Society;
- Product knowledge of Wantok Niuspepa and its target readership would be an advantage but not compulsory

Responsibilities:

- Sourcing and compiling in-depth and commercially viable newspaper supplements in both English and Tok Pisin for publication in Wantok Niuspepa
- Developing and maintaining an annual calendar of supplements
- Taking charge of all translations both for commercial and ad copy

He/She will report to the Advertising and Marketing Manager and also be expected to compile articles for publication in Tok Pisin periodically as and when required by The Editor.

All applications including CV and relevant documents are to be sent to:

The Advertising Manager
Word Publishing Company Ltd,
PO Box 1982, Boroko, NCD.

OR hand deliver to Wantok Niuspepa
Office, Central Waigani, NCD.

Applications close on COB 13th February, 2009.

Ol polis i tok Yekum i nogat rong

Andrew Molen i raitim

POLIS bilong Banz long Westen Hailans provins i tok Paul Yekum i noken sutim tok long ol long wanem ol i painim olsem em i nogat asua.

Mista Yekum i sutim tok las wik insait long *Wantok Niuspepa* (Febuari 5, 2009) olsem oi Polis bilong Banz i bin sapotim sampela man husat i traim long kilim em.

Oi i bin painim bodi bilong Peter Buno, husat i brata bilong Mista Yekum long wara

Mombol na i tok Mista Yekum i mekim posin na kilim em long pasin sanguma.

Tasol Mista Yekum i bilip sampela man i kilim brata bilong em long wanem em yet i no posin man.

Wanpela polisman long Banz polis stesen husat i no laik tokaut long nem bilong em, i tok Mista Buno i go long wara Mombol o waswas o brukim i go long hapsait, na abrus na i go aninit, dring wara na i dai. Em i tok ol i painim olsem Mista Yekum i no asua long pasin sanguma na ol i lusim em i go.

"Ol i toktok tasol mipela i no painim wanpela posin o arapela samting we mipela i ken kotim em long en, em i kamap olsem saspek tasol," polisman i tok.

Polis i no holim tu dispela ol lain husat i laik kilim Mista Yekum long wankain as.

Mista Yekum i tok olsem dispela ol man i traim long kilim em tasol em i ronawe na ol i kirap na bagarapim meri na pikinini bilong em.

"Sampela lain i helpim meri pikinini bilong mi na ol i stap nau," Mista Yekum i tok.

Banz polis i tok tu olsem

Mista Yekum i go ripot long Maun Hagen polis olsem na ol i no save gut tumas long ol arapela samting i kamap bihain long em i mekim dispela.

Provinsel Polis Komanda bilong Westen Hailans provins, Sif Supaintenden Thomas Eluh, i tok olsem em i no save gut long dispela stori long wanem em i no kisim wanpela ripot long en yet.

Mista Yekum i bin tokim *Wantok Niuspepa* olsem dispela hevi i bin kamap long em long ol mun Janueji na Febuari, 2008.

Gavman i gat K70m dinau long Nu Ailan Provinsel Gavman

Paul Zuvani i raitim

NESENEL Gavman bihain long em i givim Nu Ailan Provinsel Gavman (NIPG) K19.88 milion i gat olsem K70.32 milion dinau mani yet i stap long peim.

Dispela mani em royalti bilong Lihir Gol Main em gavman i no baim long NIPG long sampela yia i kam.

Na maski bihain long 2007 Memorandum bilong Agrimen (MoA) gavman na NIPG i no mekim wanpela samting long wanem tupela i no bihainim ol tok i stap long dispela MoA.

"Planti oi samting i no kamap long laik em mipela i laikim long em bihainim dispela MoA na olsem mipela i mas sindaun na glasim gen dispela MoA long lukim wok i kamap," Praim Minista Gren Sif Se Michael Somare i tok long taim em i givim K19.88 milion bilong dispela K90.2 milion dinau mani em Gavman i gat long NIPG long long Kavieng long Mande.

"Narapela K20 milion bilong stretim Buluminski Haiwe em gavman i givim long 2008 Saplementari Mani Plen na olsem Nu Ailan Provinsel Gavman i ken yusim sampela mani long dispela," Se Michael i tok.

Em i tok dispela em i namba wan hap bilong pemen gavman bilong em i givim na em bai givim narapela K30.12 milion long taim bihain.



AMAMAS: Se Michael (raithan) i amamas taim em bungim Se Julius taim em i kamap long Kavieng ples balus. Foto: Dipatmen bilong Praim Minista

NIPG kamapim Kaunsil bilong ol Sif

KAMAP bilong Kaunsil bilong ol Sif long lukautim na strongim kastom i bikpela samting, Praim Minista Gren Sif Se Michael Somare i tok long taim em i opim namba wan Nu Ailan Kaunsil bilong ol Nu Ailan Provinsel Gavman.

Em i tok wantaim dispela kaunsil ol arapela manmeri i ken lain na kisim save long em.

"Maski long planti senis i kamap long dispela taim em i gutpela mipela i mas holim strong ol gutpela kastom bilong mipela.

"Em i no abrus taim gavana bilong yupela husat i helpim tu long developim kantri i traim bungim ol save bilong waitman na tumbuna long taim kantri i stat," Se Michael i tok.

Em i tok long taim kantri i kisim Independens na bihain tasol long Independens kantri i bin bungim ol bikpela salens tasol em i no pundaun.

Em i tok long tude i gat planti savemanmeri we ol i stap bilong helpim kantri tasol bipo long dispela kain sindaun i no bin stap na em i bin hat long gavman bilong Papua Niugini.

OXFORD, TOK PISIN INGLIS DIKSENERI

Katim, na pulimapim oda fom daunbilo na salim i kam long Wantok Niuspepa sapos yu laik baim dispela Oxford Papua Niugini Dikseneri (Dictionary) we Wantok na Oxford i wok bung wantaim long kamapim. Dispela buk i ken helpim yu tanim Tok Pisin i go long Inglis, o Inglis i go long Tok Pisin. Hariap na kisim wanpela bilong ol dispela gutpela buk we inap strongim Tok Pisin bilong yu.

WANTOK TOK PISIN ENGLISH DICTIONARY	9780192221129	K30.00
	TOTAL	K
	PLUS FREIGHT	K
	GRAND TOTAL	K

Recommended retail price is correct at the time of printing and is subject to change without notice.

Options for Payment
 Direct deposit into Bank Account (details below)
 Mail Cheque to Word Publishing Company Ltd, PO Box 1982, BOROKO, NCD.
 Call into the office: Office 02, Section 58 Allotment 03, Waigani Dr, NCD.

Account Name: Word Publishing Company Ltd
 Account Number: 100 000 5380
 Bank: Bank of South Pacific Ltd
 Branch: Commercial Centre
 Branch Code: 8951
 Swift Code: BOSPCCPM

FAX BACK TO: (675) 325 2579

Phone: (675) 325 2500
 Fax: (675) 325 2579
 Email: word@wantok.com.pg

Name (print): Phone:
 Address (print): Fax:
 Mail: Signature:

Mani stap long graun

I kam long pes 1

"YU KEN yusim dispela ol samting inap long sampela mun o wanpela yia olgeta.

"Yu noken go long stua long baim dispela ol samting," Pater Joseph i tok.

Em i tok olsem taim ol manmeri i mekim olsem ol i ken i gat kaikai oltaim na ol i ken salim dispela kaikai tu long kisim mani.

"Wanem mani yu i gat, yu ken putim long sait long ol arapela wok olsem baim skul fi, taim bilong sik na dai, baim meri o long amamasim nupela bebi," em i tok.

Pepsi Marum, wanpela man husat i kisim dispela skul, i tok, "Planti taim mipela i save yusim pen na pepa long lainim.

"Long dispela skul, mipela i mekim wok stret long han bilong mipela na samting i pas long het bilong mipela.

"Mipela i no inap long lus tingting," Mista Marum i tok.

Em i tok skul ol i kisim i givim ol tingting olsem taim ol i pinis ol i go bek long ples na wok long graun.

Matthew Bine, sip supaintenden bilong Bomana Haus Kalabus i tok dispela i namba wan taim kain skul i kamap long dispela haus kalabus.

Em i tok em bai tokim ol kalabus manmeri na ol wokmanmeri bilong em long planim moa tapioka na lukautim ol arapela samting bilong gaden na abus bilong ol i ken kukim cistem na i no yusim mani long baim ol samting bilong stua.

Lo na Jastis Sekta Sekretariat (program aninit long ol gavman bilong PNG na Australia) i askim Pater Joseph long givim dispela skul.

Pater Joseph i bilong kantri Gana (Ghana), Afrika (Africa), tasol i wok misinari long Migende peris, Simbu provins long planti yia nau.

Nawaec kisim K4 milion

Bustin Anzu i raitim

NAWAEC ilektoret long Morobe provins i kisim K4 milion bihain long memba bilong palamen (MP) bilong ol i putim gutpela ripot long mani em i yusim.

Pablik Akauns Komiti (Public Accounts Committee) Siaman na Nawaec Open MP, Timothy Bonga, i givim ripot o akwitol (acquittal) bilong distrik long K4 milion i go long opis bilong Rurel Developmen (ORD) las wik.

Em i bin go givim dispela mani wantaim administreta bilong Nawaec distrik na ol narapela wokman bilong distrik.

Mista Bonga i tok dispela mani bai ol i yusim long ol projek insait long distrik.

Em i tok Nesenel Gavman i putim samting olsem K10 milion long olgeta distrik long kisim na mekim wok bilong ol insait long distrik na tok tu olsem, dispela K4 milion em traipela mani long mekim wok long distrik.

Dispela helpim em i hap bilong

distrik sevis impruvmen program o DSIP Mi amamas tru olsem gavman i mekim dispela kain mani fri long distrik bilong mi. Mi wantaim ol opisa bilong mi i tok amamas long ORD long helpim mipela. Na mi gat bikpela bilip olsem ORD bai helpim mipela long kisim K6 milion long taim bihain, em i tok.

ORD i tok tru olsem Mista Bonga em namba tu MP long Momase i kam givim akwitol bilong em long kisim mani. Tasol planti bilong ol MP i no givim kam dispela ripot bilong ron bilong mani insait long ol

distrik bilong ol.

Dairekta bilong ORD Paul Sai'i i tok dispela ripot em bilong soim akauntabiliti o ol i wokim ripot long rot ol i yusim mani long em na komplaiens o mekim wok tru. Dispela kain ripot bai helpim ol MP long kisim narapela mani aninit long DSIP.

Em i tok tu olsem planti bilong ol MP ino save putim kam kain ripot olsem long wanem planti taim ol opisas bilong ol i no save putim kam ripot long wokabout long mani bilong ol long ol distrik.

Bus mani em i bilong divelopmen

Andrew Molen i raitim



OL PAPAGRAUN husat i save salim diwai bilong ol nau bai kisim moa divelopmen i go long ples bilong ol.

Ol bai kisim moa helpim aninit long nupela lo bilong was o gaidlain long ol takis bilong salim diwai i go ovasis (Log export development levy).

Minista bilong ol bus (Forests), Belden Namah i tokaut long dispela ol nupela gaidlain bilong givim mani go long helpim ol dispela ples.

Nau yet gavman i save kisim K8 long wanwan kubik (cubic) bilong ol diwai bipo long ol i salim i go ovasis tasol dispela nupela helpim em bilong divelopmen tru olsem rot, skul, haus na ol arapela samting i go long ol ples.

"Astingting bilong dispela em long helpim tru ol manmeri bilong yumi i stap long ol ples.

"Em bilong mekim ol samting olsem skul, rot na haus sik long wanem taim wok i pinis na ol kampani i go em nogat moa man i stap long lukautim ol dispela samting," Mista Namah i tok.

Dispela mani em ol i bungim i go na Tras Fand (Trust Fund) we i lukautim mani bilong dispela ol divelopmen wok i gat K39. 804 milion i stap pinis long statim wok.

Dispela ol gaidlain bai go long olgeta distrik bilong ol administresen bilong ol long yusim taim ol i brukim mani long mekim wanwan wok bilong ples bilong ol.

HELPIM OL MANMERI LONG PLES: Em bikpela tingting bilong Mista Namah.

Wantok Niuspepa Poto

100 Ton Test Bed

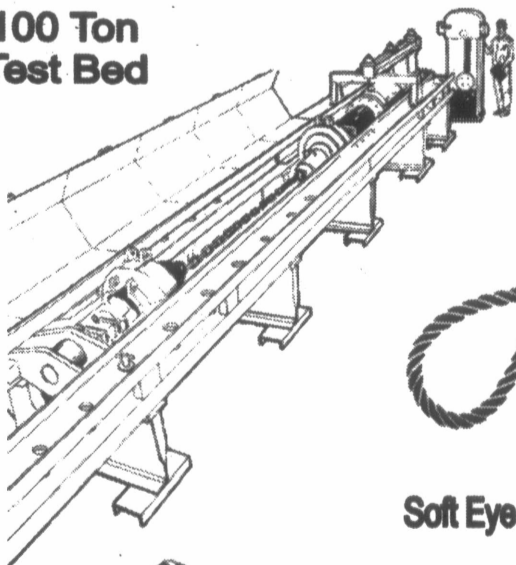

LIFTING EQUIPMENT

Wire Rope Now in Stock...



Soft Eye



Thimble Eye (Hard Eye)



Thimble & Hook



Thimble & Head Ring

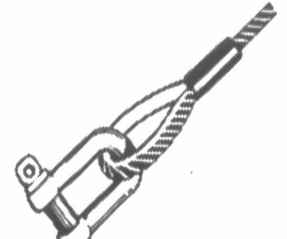

Thimble & Shackle



BISHOP BROTHERS
everything for industry...

Contact : Henry Lawson
Phone : (675) 325 1088
Fax : (675) 325 0083

Email : lifting@bishopbros.com.pg
Web : www.bishopbros.com.pg

- Engineering and Manufacture of Customised Lifting Equipment.
- Wire Rope Slings from 1.5mm to 42mm made to order.
- Mechanical Swaging & Testing of Wire Rope Slings.
- On - Site inspection of all Lifting Equipment.
- Training for Lifting and Rigging Staff

PNG givim Australia K3.9 milion

PAPUA Niugini (PNG) i givim klostu K4milion long helpim ol manmeri bilong tupela stet long Australia we tupela birua i bagarapim tru ol.

Wanpela em stet bilong Viktoria (Victoria) we klostu 200 manmeri i dai, planti tausen i kisim bagarap na lusim ol haus na olgeta samting bilong ol long ol paia i bin stat long las wiken. Narapela em stet klostu long yumi, Kwinslen (Queensland) we bikpela win na ren, raunwin Ellie i bin kamapim bikpela wara na biruaim tru planti tausen manmeri tu.

Ol paia i wok long ron yet long rurel Viktoria na i gat bilip olsem mak bilong ol manmeri i dai bai abrusim 200 mak.

Praim Minista Gren Sif Se Michael Somare i makim ol manmeri bilong PNG na salim bikpela tok sori long Praim Minista bilong Australia, Kevin Rudd long ol pen na hevi ol manmeri bilong tupela stet i bungim.

"Mi lukim dispela tupela birua long televisin na mi wari long planti manmeri long Kwinslen na Viktoria i dai, bagarap na hevi long tupela birua.

"Olsem wanpela poro, PNG i tingim long planti taim we gavman na ol manmeri bilong Australia i save helpim mipela long ol taim bilong hevi na birua." Se Michael i tok taim em i givim K3.9 milion i go long Australia long helpim ol lain i bungim birua long

Kwinslen na Viktoria.

Se Michael i tok taim em i save olsem ol manmeri bilong Australia em ol strongpela lain long taim bilong ol birua na hevi, em i bilip olsem dispela mani sapot bai helpim long daunim ol pen na hevi we ol manmeri long tupela stet i bungim.

Em i tok moa tu olsem helpim i ken strongim wok pren i stap namel long tupela gavman na ol manmeri.

Long wankain taim tu, PNG i givim K100,000 i go long Solomon Ailans gavman long helpim wantaim bikpela ren na taitwara i kamapim hevi long hap.

Usino Bundi i gat K67m mani plen

Michael Novingu i raitim

MANI mak olsem K67.1 milion em mani plen bilong Usino Bundi ilektoret 5-pela yia developmen plen long karimaut wok long kisim sevis i go long ol manmeri bilong en.

Long 33 krismas i go pinis, Usino Bundi ilektoret i no kisim gavman sevis tasol nau, ol i ken amamas long wanem gavman sevis bai i kam long ol.

Askim i go long ol manmeri bilong Usino Bundi na ol publik seven o wok lain long gavman long holim han na wok bung wantaim long kisim sevis i go long ol komyniti.

Memba bilong Usino Bundi ilektoret, Samon Kuli i mekim dispela toktok long taim bilong opim 5-pela yia developmen plen bilong ilektoret bilong em we em i givim long praim minista Se Michael Somare las wik Fraide long Usino gavman stesin we moa long 2000 manmeri i kam bung long lukim.

Mista Kuli i givim mani mak long kirapim wok developmen i sanap olsem; Rot na Bris K35m, Edukesen K12m, Helt K7.5m, Wok Didiman K6.5m, Lo na oda K2m, Wok Wara saplai K1.5 m na putim ilektrisiti (lait) K250, 000.

Long wankain taim em i givim ol kar i go long ol distirk bilong em long karimaut wok long kisim sevis i go long ol manmeri bilong ol.

Ramu Suga helt senta, Begesin na Usino helt senta i kisim wan wan ambalens long karimaut wok bilong ol. Ten sita kar i go long edukesen na banana bot wantaim moto i go long Gama Lokel Levul Gavman.

Mista Kuli i tok Usino Bundi i wanpela las distrik we long 20 yia i go pinis i nogat gavman sevis i kam long en. Olsem ol pipel i mas amamas long sevis bai i kam long ol.

"Distrik bilong mipela i gat planti risos olsem Ramu Nikel projek, Yandra Gol Main, Ramu Welpam projek, bai kirapim developmen long Madang na apim ikonomi bilong Madang na PNG," Mista Kuli i tok.

Em i askim ol divelopa i stap wok long distrik bilong em long helpim em long givim sevis i go long ol manmeri bilong em long kirapim gutpela sindaun bilong ol.

Polye tokaut long K1.bilion bilong transpot sekta

James Kila i raitim

MINISTA bilong Woks, Trenspot na Sivil Aviesin, Don Polye i tokaut olsem insait long K6 bilion baset o mani plen bilong 2009, transpot sekta i kisim K1.02 bilion.

Dispela em i gutpela sain tru we i ken lukim developmen i go insait long Papua Niugini (PNG).

Mista Polye i bin tokaut long dispela long pas wik long Lahame insait long Unggai-Bena distrik taim em i go wantaim Envairomen na Konvesesen Minista, Benny Allan long autim 5-pela yia distrik plen na tu mekim graun bruk seremoni long tupela rot projek we mani mak em moa long K48 milien.

Mista Polye i tokaut olsem Somare-Temu gavman i givim gutpela luksave long infrastraksa sekta, we transpot em wanpela na dispela em i gutpela plen tru bilong gavman.

"Taim yumi lukim infrastraksa i gro, sosio-ikonmik developmen bilong kantri bilong yumi bai kamap gut," Mista Polye i tok.

Em i tokaut tu olsem insait long planti ol stadi dispela ol kantri we i gro hariap tru-em dispela ol kantri we i givim

moa sapot na mani long infrastraksa developmen.

Mista Polye i tok amamas long Dipatmen bilong Woks, Transpot, Nesenel Plening na Fainens ria Treseri long helpim ministri bilong em long redim ol bikpela projek bilong kantri.

- Sampela ol bikpela projek em i tokaut long en em: Wol Benk program we bai i lukim moa long K400-milion bai mekim wok insait long Midium Tem;

- AusAID TSSP program we moa long K700-milion mak bilong ol rot projek bai wok i kamap long en insait long 4-yia medium tem;

- Esian Developmen Benk (ADB) we moa long K2.7 bilion mak bilong Trenspot sekta wok bai i kamap insait long narapela 10-pela yia.

Mista Polye i tok tu olsem ol i mas i gat moa mani yet long sampela ol wok we i stap yet na ol nupela projek proposal o wok ol i laik mekim na pepa wok i stap pinis.

Em i tok olsem bikpela salens nau em long infrastraksa sekta na Trenspot long go insait long ol Pablik, praiwet patnsasip (PPP) wok plen long yusim gut ol risos long mekim wok i kamap.

PABLIK NOTIS



BANK OF PAPUA NEW GUINEA

LASPELA SANS

Benk bilong Papua Niugini (BPNG o Sentrel Benk) i bin luksave olsem planti manmeri long PNG i stap long ol ausait hap tru bilong kantri na i no inap kisim o kisim hariap ol toksave we i kamap long midia olsem long niuspepa, redio na televisin. Olsem na taim Benk bilong Papua Niugini i bin putim toksave long midia olsem ol manmeri i mas kisim ol pelpa K1 koin i go long ol benk long senisim na kisim hupela K1 koin, dispela toksave i stap tripela yia olgeta long ol niuspepa, redio na televisin, long Novemba 2005 inap Disemba 2008, long givim ol manmeri inap taim long kisim toksave na bi-hainim

Anint long lo, stat long Disemba 31, 2008, ol manmeri i no inap yusim ol pelpa K1 koin moa. Em i no moni moa. I gutpela long lukim olsem ol manmeri i wokbung wantaim ol benk long rausim ol pelpa K1 koin. Ol benk i kisim bek planti ol pelpa K1 koin pinis. Tasol ol manmeri i holim yet sampela ol pelpa K1 koin. Long givim sans long ol dispela manmeri husat: holim yet sampela ol pelpa K1 koin, Benk bilong Papua Niugini i bai 'baim bek' ol pelpa K1 koin inap Jun 30, 2009.

Putim ol pelpa K1 koin long ol liklik pasol - K50 insait long wanwan pasol - putim nem na adres bilong yu long pasol, na salim i kam long Benk bilong Papua Niugini namel long nau na Jun 30, 2009. Benk bilong Papua Niugini bai peim yu K1 bilong olgeta ol pelpa K1 koin em i kisim long yu. Toksave olsem ol bai baim bek ol pelpa bikpela K1 koin tasol. Ol i no inap baim bek ol koin moni bilong ol narapela kantri o ol narapela kain kain samting. Sapos ol i kisim kain ol samting olsem, ol bai rausim na tromoi. Toksave tu olsem ol i no inap peim freit o pe bilong salim ol dispela koin long pos opis i kam long ol.

Sapos yu stap long Nesenel Kapitol Distrik na ol hap klostu, yu ken toktok long telepon wantaim Menesa bilong Benking Dipatmen long redim taim bilong senisim moni bilong yu. Ol telepon namba bilong Menesa bilong Benking Dipatmen em 3227200 na 3227279.

Yu ken salim ol koin i kam long:-

The Manager
Banking Department
Bank of Papua New Guinea
P.O. Box 121
Port Moresby
National Capital District

.....
L. Wilson Kamit, CBE
GAVANA

Yumi laikim senis o nogat?

Se Michael askim ol manmeri bilong Usino Bundi

Michael Novingu i raitim

Askim i go long ol woklain long gavman long Madang long wok hat na kisim sevis i go long manmeri long ples.

"Usino Bundi distrik i stap long tudak. Mi kam raun lukluk long kisim sevis i kam long ol manmeri.

"Taim wok developmen i kirap long kisim sevis i go long ol manmeri, ol manmeri i noken askim long kompensesen long graun gavman save bai stretim ol bagarap i kamap long graun bilong yupela."

Gren Sif Prait Minista Se Michael Somare i mekim dispela toktok long autim bilong Usino Bundi ilektoret faiv (5) yia developmen plen long Usino gavman stesin las wik Fraide.

Se Michael i tok ol woklain bilong pablik sevis i mas wok hat na wokbung wantaim ol manmeri long ples long kisim sevis i go long ol.

"Yumi laikim senis o nogat?" Se Michael i askim.

Em i tok olsem sapos ol manmeri i laikim senis, mobeta ol i wokbung wantaim long

trupela na stretpela rot long kirapim gutpela sindaun long ol komyuniti bilong mipela.

Se Michael i tok olsem ol manmeri i mas putim mani i go stret long wok ol i kirapim. Noken putim long arapela samting.

Taim yupela i givim kontrak long karimaut long ol projek, glasim gut givim wok long ol kampani bai karimaut wok long trupela na stretpela pasin, em i tok.

Na tu i gat ol samting na save long karimaut wok, Se Michael i tok.

Noken wokim haus long Lae

Bustin Anzu i raitim

OL LIDA long Bulolo long Morobe provins i no laikim ol maining kampani i wokim ol haus long biktaun Lae. Ol i laikim ol i mas wokim haus klostu long ples we maining i stap long en.

Dispela kampani, Morobe Maining Join Vensa (Morobe Mining Joint Venture), i bin makim ples na ol i bin mekim graun i redi long ol i wokim ol haus, tasol dispela hap ples nau bus i karamapim na stap nating.

Kampani i kirap kisim lis (lease) wantaim wanpela bikpela kampani we save wokim ol haus, na wokim haus bilong ol woklain bilong em long 9 Mail long Lae.

Memba bilong Bulolo, Sam Basil, Wau/Bulolo Eben Lokel Levol Gavman (LLG) Lod Meya, Jack Nawei na Wau Rurel LLG Presiden, John Yawa, i bin tokim wanpela bikpela lain grup long Santu Peter Praimeri Skul long Bulolo long dispela las wik.

Ol i tok dispela plen bilong kampani long wokim haus long Lae i no gutpela long tingting bilong ol long kirapim ples.

"Mi laik toksave long dispela kampani olsem wokim haus bilong ol wokmanmeri bilong en long Lae i no gutpela pasin. Lae i no Wau. Mipela i bin makim ples na

mekim redi long ol i wokim haus, tasol ol i no kam wokim.

"Kampani mas bihainim dispela agrimen ol i bin wokim pastaim," Mista Basil i tok.

Ol lida i bin tok ol bai pait strong long ol kain sevis i mas stap bek long Bulolo na i noken kisim stail bilong 1930 i go bek gen long taim bilong 'Bulolo gol ras.'

Tasol kampani i bekim long wanpela pas na tok klia olsem ol i no wok long Hidden Veli long Wau tasol ol i gat wok bikpela wok komitmen long mekim aninit long Hidden Veli agrimen we bai ol i ken sapotim komyuniti wok bilong Wau na wokbung wantaim olgeta levol long gavman na tu kamapim sampela sevis olsem ol rot na ol narapela sevis bilong gavman.

Kampani i tok ol haus ol i wokim long 9 Mail em long sapotim ol wokmanmeri husat bai wok long administresen na lojistik. Em i tok astingting bilong en em long ol konstraksen na komisining bilong Hidden Veli gol main, we taim em i operet, bai kamapim bikpela mani we em i mas i gat long sapotim wok bisnis long provins na ol gavman sevis olsem ol haus long Wau. Kampani i tok ol i mekim wok painim aut long gutpela rot ol i ken bihainim long go hetim dispela program bilong haus i ken kamap long Wau.

Planti hap bilong Simbu rot i surik na bruk

James Kila i raitim

OL hevi bilong graun bruk na bagarapim rot insait long ol hap bilong Okuk Haiwe long Simbu provins bai go het yet long wanem planti ol hap bilong maunten graun long dispela provins i no stap stret. Ol i save surik surik taim i gat bikpela wara i stap long en.

Dispela em bikpela toktok wanpela rot enjinia wantaim Dipatmen bilong Woks i bin mekim i no longtaim i go pinis long Goroka, lsten Hailans provins.

Enjinia i tok olsem planti ples insait long Simbu i stap long maunten na tu rot i katim long sait bilong ol maunten na bai i gat hevi yet long wanem graun i save surik surik taim i gat wara i stap insait long en.

Toktok i tru long wanem planti ol hap bilong rot long Simbu bihain long yu lusim Kundiawa na go olsem long Kerowagi i wok long bagarap hariap tru, maski olsem ol wokman bilong rot i stretim pinis.

Gavman bai i lusim planti bikpela mani long stretim ol hap rot long Simbu provins long wanem taim wok i pinis, hevi bai i kamap yet.

Sampela ol hap bilong rot we i wok long bungim hevi yet long graun i bruk na bagarapim ol rot em long Mindima we i stap 8 kilomita lusim Kundiawa taun i go olsem long Hagen rot, hap bilong rot long Ouna na tu sampela ol hap moa bihain. Wantok Niuspepa i bin lukluk raun i go olsem long Simbu long las wiken na i skelim olsem toktok bilong dispela enjinia em i tru.

Niu Yia Seil wantaim Crazy Sam!!

OLGETA MERCEDEZ EM 50% OFF!

NUPELA STOK I KAM PINIS!!

STOCK	YIA	WANEM KA	BIPO	NAU		
1 TGH4143H	2000	MITSUBISHI LANCER	32,800.00	29,520.00	3 TO CHOOSE FROM	10%
2 TGH4348H	2002	MERCEDEZ E240 EXECUTIVE SEDAN	85,000.00	55,250.00	3 TO CHOOSE FROM	35%
3 TGH4313H	2000	NISSAN SKYLINE LATE MODEL	75,000.00	48,750.00	1 LEFT	35%
4 TGH4412H	2002	MITSUBISHI PAJERO	85,000.00	63,750.00	1 LEFT	25%
5 TGH4433H	2000	HONDA CITY FAMILY CAR	37,000.00	31,875.00	2 TO CHOOSE FROM	15%
6 TGH4431H	000	TOYOTA LANDCRUISER STATION WAGON	155,000.00	100,750.00	1 LEFT	35%
7 TGH4444H	2001	MAZDA SEDAN 323 GREAT FAMILY CAR	29,900.00	22,425.00	4 TO CHOOSE FROM	15%
8 TGH1212F	2000	LEXUS ALTEZZA SPORTS SEDAN	58,900.00	44,175.00	1 LEFT	25%
9 TGH1264F	LATE MODEL	TOYOTA CORROLLA LATEST MODEL	55,900.00	41,925.00	LAST ONE	15%
10 TGH1282F	LATE MODEL	SUBARU FORRESTER - GREAT FOR FAMILY	55,900.00	41,925.00	3 TO CHOOSE FROM	15%
11 TGH1280F	LATE MODEL	TOYOTA PRIEMIO CORROLLA	54,500.00	40,875.00	LAST ONE LEFT	25%
12 TGH1285F	LATE MODEL	NISSAN SUNNY N16 MODEL	35,500.00	30,175.00	4 TO CHOOSE FROM	20%
13 TGH1287F	LATE MODEL	HYUNDAI MATRIX SEDAN	29,000.00	23,200.00	3 TO CHOOSE FROM	20%
14 TGH9045A	1998 MODEL	HONDA CRV STATION WAGON	35,500.00	31,950.00	6 TO CHOOSE FROM	10%

RINGIM MIPELA NAU LONG FON: 323 1733

Freeway Motors
YUMI YET

Email: carsales@freewaymotors.com.pg

Driven by Innovation!

Hariap! Nogut yu nogat sans yah!!!

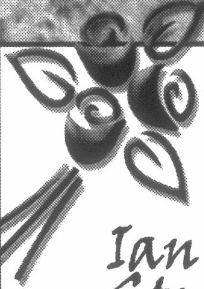

Tok Sori

Ian Stuart Snell

Bonde: 17/12/1936
Dai: 1/2/2009

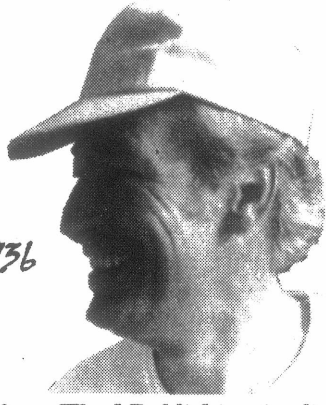

Ol wokmanmeri bilong Word Publishing i salim bikpela Tok Sori long Femili bilong Ian Stuart Snell husat i dai long ples bilong em long Sydney Australia. Ian em i wanpela Voluntia na Bod Memba inap long yia 2007.

Mipela tu i stap wantaim yupela long dispela taim bilong sore na Papa God i ken givim yupela bel isi long dispela taim.

Malolo Gut!



Simbu laikim ol savemanmeri

Michael Novingu
i raitim

“Long Simbu mipela i save lukluk long sapotim na kisim mani long ol savemanmeri.”

Em toktok bilong Gavana bilong Simbu provins, Pater John Garia.

Mista Garia i tok olsem long dispela yia ol i wok long lukim olsem planti ol pikinini i gat save long skruim save na i go long bikskul em ol pikinini bilong ol manmeri husat i nogat planti mani.

Mista Garia i tok gavman bilong em bai helpim ol dispela papamama long baim ol skul, stat long elementari prep na i go sekondari skul na teknikal wantaim FODE or fleksibel distens edukesen.

Em i tok orait long mani mak we ol papamama i baim olsem: Elementri prep i go elementri 2 - K10.00; gret 3 i go long gret 5, K20.00; gret 6 i go gret 8, K100.00; gret 9 i go gret 10; K540.00 long de sumatin na K810.00 long slip insait long skul; gret 11 i go gret 12 - K720.00 long de

sumatin na K1080.00 long slip insait long skul na ol teknikel skul - K540.00 long de na K810.00 long slip insait long kolis na long FODE em K60.00.

Long wankain taim, Ekting Administreta bilong Simbu, Joe Kunda, i tok planti skul i gat planti mani tasol i no save yusim gut long wok bilong ronim skul i go inap long pinis bilong yia.

Mista Kunda i tok strong long dispela long taim bilong lonsim skul fi long Kundiawa na i tok planti ol het tisa na ol bod memba i save

wok long pinisim mani long namel taim bilong yia na i nogat mani bilong pinisim skul na long statim skul.

Em i tok ol het tisa bilong ol skul insait long Simbu i mas i yusim gut skul mani long mekim wok stret.

Prinsipel Advaisa bilong Simbu Edukesen, Walkaima Essy i tok tenkyu long Mista Garia na administresen bilong em olsem, Simbu em i save gro na sanap long save bilong ol.

Mista Garia i tok Simbu i bilip long strongim ol savelain.

Ol Hailans save senisim ol lida olsem “andapens” bilong ol’

James Kila i raitim

OL BIKPELA wok we bikpela milion mani i save go long en i no save go het long wanem ol manmeri i save senisim ol lida klostu klostu.

Dispela em bikpela toktok Minista bilong Edukesen na Memba bilong Tari Pori, James Marape.

Em i mekim dispela toktok las wik Tunde long Lahame long Unggai Bena distrik.

Mista Marape wantaim Minista bilong Transpot, Woks na Sivil Aviesen, Don Polye i bin go wantaim Minista bilong Konvesin na Enviromen, Benny Allan long opim ol wok projek long Unggai Bena distrik.

Mista Marape i tokim ol manmeri olsem pasin bilong senisim ol lida olgeta taim i save mekim planti ol bikpela projek i no save go het.

Em i tokaut olsem wanem projek wanpela lida i putim wok plen long kamapim em taim narapela lida i go insait long palamen planti taim ino save mekim i go het na planti taim dispela ino save kamap.

“Planti taim yumi ol lain long Hailans i save senisim ol lida bilong yumi olsem yumi senisim ol andapens bilong yumi,” Mista Marape i tok.

Em i tokaut olsem planti taim ol pepa-wok em ol lida i mekim i save go insait long planti ol kain sistem bilong wok na i save kisim taim.

Mista Marape i tok ol provins long Niugini Ailans i wok long lukim ol bikpela developmen i go het moa yet long wanem ol lida bilong ol i save stap insait long palamen moa long 10 na 15 yia.

Em i tok provins olsem i no save senisim ol lida klostu klostu olsem ol lain long Hailans.

Tingim ol manmeri pastaim

Bustin Anzu i raitim

SIF Jas bilong Papua Niugini (PNG) i askim ol pablik sevis long kantri long tingim ol manmeri pastaim long wok bilong ol.

Se Salamo Injia i tok mama lo bilong kantri i tok husat ol wok long gavman i mas tingim ol manmeri pastaim long ol narapela samting.

“Gavman i no bisnis na nogat wanpela wokmanmeri bilong pablik sevis bai wokim bisnis long dispela.

“Mipela i mas lus tingting long hevi bilong mipela yet na tingim ol

manmeri pastaim,” em i mekim dispela toktok taim em i kam long Lae long opim Morobe Provinsel Gavman yia long las wik.

Sif Jas i bin tokim ol wokmanmeri bilong pablik sevis long dispela taim olsem dispela kain singaut em i no namba wan taim em i mekim.

Em i tok tu olsem ol wokmanmeri bilong pablik sevis em ol rot bilong kisim sevis long gavman na ol dispela rot i noken pas tasol em i mas stap klin olgeta taim.

“Taim mipela i mekim dispela rot i klin na fri, ol

narapela samting bai isi. Tasol sapos dispela rot i rong o blok, ol narapela samting bai hat long kam,” em i tok.

Em i tok em i amamas long lukim Morobe Provinsel Gavman i putim namba wan de bilong ol long wok long han bilong God.

Long wankain taim tu, Gavana bilong Morobe, Luther Wenge i tok 2009 em yia bilong tingim God, Morobe i kisim bikpela blesing las yia. Morobe i no bin kisim bagarap long las yia olsem hai wara i bagarapim Oro provins na ol narapela hap.”

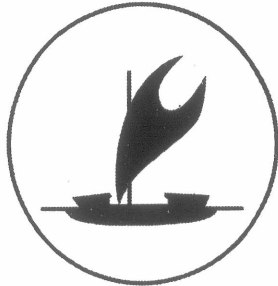

PUBLIC NOTICE

The National Capital District Commission Sport Desk will be organizing all suburbs within NCD to participate in the following sports to be played in your respective areas.

Volleyball, Soccer, Netball, Rugby Touch

The aim of the launching of this suburban games is to select best quality players to represent NCD in each sport for the forthcoming National Games to be played here in (NCD) in November, 2009.

Any interested persons and sports personnel are most welcome to participate and can contact Kila Dick, or Sports Coordinator Ms Daniel Paliau on telephone No: 325 0280 Ext: 236; Or on the following address:-

NATIONAL CAPITAL DISTRICT COMMISSION
DEPT OF COMMUNITY & SOCIAL SERVICES
1ST FLOOR LAGATOI HAUS
P.O BOX 7270
BOROKO
NCD

Authorized by:
Lesley Alu
City Manager



PAINIM PIS: Ol mangi long Madang i sanap long hap bilong ol sip i tromoi rop long anka klostu long Jant bris long basis bilong Madang. Ol dispela mangi i tromoi huk long painim pis.
Poto: Se Peter Barter



EM BAI KAM OLSEM: Ekting Dairekta bilong Nesenel Weda Sevis, Sam Maiha, i soim ol sampela niusmanmeri long rot we ren, win na bikpela solwara bai kamap long en. *Wantok Niuspepa Poto*



SKUL: Dijisel (Digicel) volantia, Magdalen Kedek, i skulim ol pikinini long nupela pri skul long 6 Mail setelmen long Mosbi ol i opim tasol. *Poto: Dijisel*



YAMAHA



KEROSENE

Outboard Motor

- ✓ 40hp
- ✓ 2 Stroke
- ✓ Kerosene Premix
- ✓ Pin Propeller

Beat the Price Rise!

Special Price!

K5,900

Price Includes SGT

- ✓ Low Fuel Consumption
- ✓ Reliability & Durability
- ✓ 100% After-market support



Your First Choice

LIMITED STOCKS LIMITED TIME!

For More Information or Sales enquiries Contact :

Phone : 3229400 · Fax : 3217268 · Port Moresby or Phone : 4781800 · Fax : 4722463 · Lae

www.elamotors.com.pg · Offer Expires : 28 / 02 / 2009.



Em wok bilong ol papamama tu long skulim ol pikinini

I kam long Zenit Nius

OL PAPAMAMA i mas bilip olsem ol inap givim gutpela Kristen skul long ol pikinini bilong ol, na tu, mekim wok long lukim olsem ol pikinini i mas i gat edukesen, wanpela saveman i tok insait long namba 6 Wol Kibung bilong ol Famili we i bin kamap long Meksiko (Mexico).

Profesa bilong Tioloji long Katolik Yunivesiti bilong Amerika (United States of America), Michael Waldstein, i tok dispela taim em i givim ripot, 'Famili: Kamapim ol Human na Kristen Velyu:

Glasim long Amerika na Kanada' (Canada).

Glasim tingting long piksa bilong gutpela Kristen famili we Pop Benedict 16 i bin tokaut long pas bilong em insait long wanpela famili bung long Valensia, Itali (Italy), Mista Waldstein i bin askim sapos dispela kain piksa long famili i stap long Amerika na Kanada.

Em i tok i gutpela olsem planti famili i save bihainim wok misin bilong ol, tasol planti tu i save sot long mekim dispela long wanem ol i lusim ol skul na ol bikskul i mekim ol dispela wok.

Tasol em i tok moa olsem planti ol skul nau i senis na ol i

no moa skulim tumas ol gutpela Kristen pasin.

Mista Waldstein i tok olsem ol pikinini i save stap planti awa long skul, i no long haus, na em i hat long ol long ol pikinini long poro gut wantaim ol papamama bilong ol. Olsem na taim ol skul i malolo tu na ol pikinini i stap longpela taim long haus, ol i no save stap klostu tumas wantaim ol papamama bilong ol. Nogat. Ol bai laik stap ol yet o pilai wantaim ol wan krismas bilong ol.

Mista Waldstein i tok tu olsem taim ol pikinini i wok long kamap ol yangpela manmeri, ol i hariap long wokim ol prenpasin, na pasin nau em long yusim wanpela narapela

tasol long amamasim ol yet.

Musik tu, Mista Waldstein i tok, em wanpela samting ol yangpela manmeri yusim long soim olsem ol i kros o amamas.

Mista Waldstein i luksave long wanem ol papamama tu i save pilim taim ol i lukim olsem ol narapela lain i pulim ol pikinini bilong ol i go longwe long ol. Tasol ol papamama i mas wok long poro gut wantaim ol pikinini bilong ol.

"Yumi mas tingim olsem em i wok bilong yumi olsem ol papamama long skulim ol pikinini bilong yumi.

"Yumi mas stap wantaim ol sampela taim na skulim ol gut," em i tok.

STORI TASOL
wantaim
Fr Paul Liwun



Husat bai tokim mi?

THERESA Wongos em i wanpela nes long wanpela haus sik. Mi laik tokim yupela wanpela stori em i tokim mi.

Wanpela famili i bin bringim wanpela lapun man i gat sik TB i go long haus sik. Wongos i bin stretim ol pepa samting na helpim ol dokta i sekim dispela lapun man.

Wongos i bin askim dispela lapun man planti askim, olsem;

- Wanem taim mama i karim yu?;
- Hamas krismas bilong yu?; na
- Hamas manmeri long famili bilong yu i gat sik TB?

Wongos i raitim bekim bilong olgeta dispela ol askim long pepa inap long las askim. Las askim, "Wanem lotu bilong yu?"

Dispela lapun man i kirap nogut long dispeal askim, tasol em i amamas tu. Em i apim pes bilong em na lukluk strong long ai bilong Wongos na i tok, "Pikinini,...taim mi yangpela i kam inap nau...mi laik lotu wantaim Katolik. Tasol nogat wanpela man o meri i askim mi. Yu namba wan man o meri long askim mi dispela."

Wongos i tokim mi, "Pater, taim mi harim bekim bilong dispela lapun man, mi pilim amamas long wanem mi wanpela Katolik nes.

"Tasol long wankain taim tu, mi pilim sem, long wanem bekim bilong dispela lapun man i sutim bel bilong mi. Dispela em long wanem, mi wanpela Katolik nes, tasol sampela taim mi save sem long soim bilip bilong mi long wok ples o long ples mi stap long en."

Taim mi harim stori bilong Wongos, mi amamas tru, long wanem dispela em i wanpela trupela stori. Long wanem na planti bilong yumi i save sem long soim bilip bilong lotu bilong yumi long narapela?

Planti bilong yumi i gat lotu na yumi save kolim yumi yet ol Kristen manmeri. Olsem ol Kristen manmeri yumi bilip olsem Buk Baibel em i Gutnius. Long wanem yumi no laik autim dispela Gutnius wantaim ol narapela?

I gat planti rot bilong autim Gutnius o bilip bilong yumi, i no long maus o toktok tasol.

Namba wan rot bilong autim bilip bilong yumi, em i bilong mekim tok bilong God i kamap laip long laip bilong yumi.

Sapos yumi mekim gutpela wok long laip bilong yumi olgeta taim, dispela we yumi mekim Tok bilong God i kamap laip. Olgeta gutpela wok yumi mekim inap long helpim ol narapela manmeri i luksave long God.

I gat planti manmeri i stap longwe long lotu, i kamap lus Kristen. Pasin na wokabaut bilong ol i no soim olsem ol i bilip moa long God. Olgeta Kristen manmeri i mas mekim Gutnius i kamap laip, helpim narapela long luksave long God na kam bek long lotu wantaim yumi gen.

LUKSAVE LONG SANTU ANTHONY

PASIN: Wanpela man i ron long hos bilong i go insait long wanpela bikpela paia long San Bartolome de Pinares long kantri Spen (Spain), long Fraide, Janueri 16. Planti narapela man tu i bin mekim olsem long luksave long Santu Anthony, santu bilong ol animol.

Poto: AAP/AP/Victor R. Caivano



Noken salim bia long kain kain hap long Hela, ol sios na komyuniti lida i tok

Timon Henry i raitim

OL SIOS na komyuniti lida long Hela rijen i askim Sauten Hailans Provinsel Lika Laisens Bod na Komiti long putim tambu long salim na baim bia long Hela rijen, bihain long planti manmeri i bin kisim bagarap na dai long wanem long hevi bilong bia long yia i go pinis.

Ol dispela lida i tokim *Wantok Niuspepa* olsem ol manmeri i no pilim sef long raun long taun, long wanem, i gat planti bia klab

long olgeta hap insait long Hela.

Wanpela ripot i bin kamap long taim bilong Krismas na Nu Yia em wanpela mama bilong ples Hogombe long Hulia lokel levul gavman husat i bin kam long Tari haus sik i bin karim pikinini arere long rot long wanem planti spakman i pasim rot bilong em long i go long haus sik.

Olgeta lida i askim Sauten Hailans Provinsel Lika Laisens Bod na Komiti long pasim bia long olgeta hap bilong distrik na

ol rausim bia laisens. Ol hap long dring tasol i mas long Ambua Los o long Gibur Los, ol lida i tok.

Ol Provinsel Lika Laisens Bod na Komiti i save tok orait o nogat long husat i laik kisim laisens bilong salim bia.

Long dispela taim tu, ol lida i tok olsem memba bilong palamen bilong dispela provins i redi na wok hat long bikpela wok olsem PNG Likwifait Naturel Ges (PNG LNG), na pasin bilong dring bia na kamapim hevi bai bagarapim ol kain wok olsem.

Yabim Lutheran Sios Distrik kisim mani long helpim wok

Paulus Tali i raitim

YABIM Lutheran Sios Distrik dispela yia i gat wok long lukautim namba 27 sinot o kibung bilong Evangelikel Lutheran Sios bilong Papua Niugini.

Em i bikpela wok, na bikpela wok ministri bai kamap long dispela taim. I mas i gat mani long mekim gut ol dis-

pela wok. Gavana bilong Morobe, Luther Wenge, i luksave long dispela na givim K50,000 long helpim wok ministri bilong ol Lutheran pasto long Yabim.

Presiden bilong ELC/PNG long Yabim distrik, Pasto Gedion Okaimasa, i tok tenkyu long helpim bilong Mista Wenge.

Pasto Okaimasa i tok ol sios memba i mas

kliia olsem dispela mani i kam long fan skim bilong Mista Wenge long helpim ol peris na evanjelis. Ol bai kolim skim aninit long pastaim bisop bilong Yabim, "Yana Apo" we bai sapotim ol sios wokman bilong Yabim.

Mista Wenge i askim ol 31 Lutheran memba bilong palamen long givim sapot bilong ol i go long ol wok bilong ol sios ministri.

Givim gutpela sevis

SANS SKUL

LAINIM: Ol pikinini bilong 8 Mail ausait long Mosbi i gat sans nau long skul na tok tenkyu i go long bikpela mobail telepon kampani, Dijisel (Digicel), long helpim givim ol skul buk na ol samting olsem long ol pikinini long Enei Monou Pri Skul na Literesi Senta las wik Fonde. Dijisel i bin sanapim na opim nupela skul long Oktoba las yia.

Poto: Dijisel

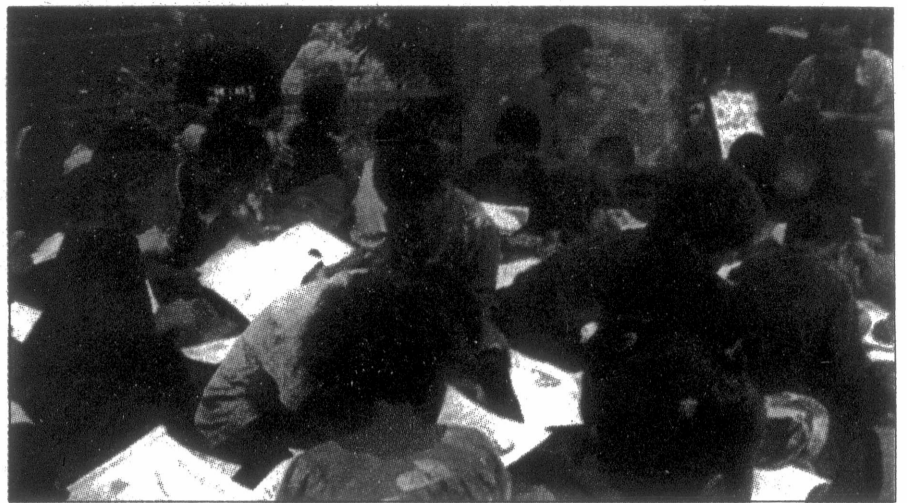

Bustin Anzu i raitim

PRESIDEN bilong Waria Lokol Levot Gavman (LLG) i mekim strongpela toktok olsem ol advaisa bilong helt na edukesen ong Morobe Provinsel Gavman i no givim sevis olsem ol i bin promis.

Kaunsil Presiden, Morokoi Gaiwata, i tok tingting long putim ol asples man long wok long helt na edukesen i no wok long Garaina na Waria olsem ol bin tok promis long en.

Mista Gaiwata i no amamas long ol helt na edukesen advaisa bilong Morobe Provinsel Gavman long wanem, ol i no tingim promis bilong ol olsem ol i mas givim skolasip i go long ol gret 12 sumatin bilong Waria LLG aninit long Gerson-Solulu skolasip skim (Scheme).

Dispela tingting em olsem taim ol sumatin i pinis long skul bilong helt na edukesen, ol bai

kam bek na wok long ples bilong ol.

Dispela tingting i bin kirap bihain long planti ol helt wokmanmeri na tisa i les long go wok long ol ples olsem Garaina na Waria.

Long narapela nius ol tisa long Morobe provins i mas kisim ol toksave long skul ol bai wok long en insait long provins na maski long poinim pinga i go i kam na i no go long ol skul.

Ekting Provinsel Administrata bilong Morobe, Patilas Gamato, i mekim dispela strongpela tok lukaut long ol tisa long provins.

"Tingim wok bilong yu na ol famili bilong yu. Wanem samting yu mekim na toktok bai bagarapim wok bilong yu yet," em i tok.

Dispela kain kros namel long ol tisa bai bagarapim stat bilong skul na ol i no inap tingting long skul, em i tok.

Nau yet, em i tok ol tisa i mas stap long ol skul na redi long skulim ol pikinini.

Hai skul i gat nupela trakta

Bustin Anzu i raitim

NAWAEC Luteran Hai Skul long Nawaec ilektoret, Morobe provins, i kisim helpim long Morobe Provinsel Gavman long baim nupela trakta.

Provinsel gavman i yusim mani bilong en insait long Provinsel Developmen Gran (Provincial Development Grant) long baim dispela trakta bilong dispela hai skul.

Dispela trakta em ol i baim long mani mak long K90, 000, we bai helpim skul long mekim wok agrikalsa o wok didiman na tu ol narapela samting olsem long bilasim skul.

Ekting Provinsel Administrata, Patilas Gamato, i tok provinsel gavman i mekim tok promis long kamapim gut wok bilong edukesen long provins.

"Edukesen em i wanpela bikpela samting we i mas gat strongpela sapot long helpim ol yangpela manmeri bilong nau long kamapim na strongim wok developmen long kantri.

"Morobe i laikim ol yangpela manmeri long kamap ol lida," em i tok.

Long wanpela taim we nesenel gavman i wok long lukluk strong long agrikalsa o wok didiman, em i gutpela long lukim ol skul na bikskul i lukluk long strongim ol kain wok olsem.

Em i gutpela long lukim ol provinsel gavman strong ol skul na bikskul long mekim ol dispela kain wok.

TELISAT

"What is it?"

TELISAT is Telikom's powerful new communication tool, the VSAT (Very Small Aperture Terminal) system offers a wide range of satellite solutions to deliver voice, internet, and other solutions to different array of users' nation wide. It is the perfect technology platform to deliver vital communications link within the reach of isolated PNG communities. TELISAT is smaller, less expensive, less power-dependent and is a simple modern technology creating communications revolution in Papua New Guinea. This system provides six telephony lines and an optional IP port. Through its carriage of voice and IP services, low cost Teli-Sat is opening up the world of telephony and Internet communications to previously isolated areas of Papua New Guinea.

Now available on Tabar Is

Call Tabar Island in New Ireland Province now from the following TELISAT Telephone numbers:

2759666, 2759667, 2759668, 2759669, 2759670, 2759671



TELIKOM PNG CUSTOMER ASSISTANCE NUMBERS

NATIONAL DIRECTORY ASSISTANCE	013	INTERNATIONAL OPERATOR ASSISTANCE	016
TELEPHONE FAULTS	014	PNG REVERSE CHARGE CALLS	011
DATA FAULTS	0175	INTERNATIONAL DIRECTORY ASST	0178
TELIKAD, RAIT PREPAID ASSISTANCE	323 4444	TELIKOM GENERAL ENQUIRY	300 5000



TELIKOM PNG LIMITED
Always there!



TAIM NOGUT...HEVI: Ol wokmanmeri long haus sik i helpim Ahmed Muhammad. Ahmed i gat 15 krismas na em i kisim bagarap long bodi bilong em taim wanpela bom i pairap long Bagdad (Baghdad), Irak (Iraq), long Sande, Febuari 8. Tupela arapela man i bin dai taim dispela bom i pairap, na 11-pela arapela manmeri kisim bagarap. *Foto: AP/AP/Karim Kadim*

Putim tambu long smuk

ASKIM i go long Minista bilong Helt, Sasa Zibe, long putim tambu long ol manmeri long smuk long ol pablik hap.

Dispela em ol ples olsem ol haus kaikai o ol pies bilong kaikai, long ol PMV bas, teksi na balus ol hap bilong dring o danis, na ol opis.

Presiden bilong Papua Niugini Medikel Sosaiti (PNGMS), Dokta Mathias Sapuri i bin mekim dispela askim bihain long ol ripot i soim olsem mak long sik olsem kensa bilong lang o bros i go antap na wanpela bikpela as long en em smuk.

PNGMS i wari long ol ripot we i soim olsem i no ol lain i smuk i kisim sik olsem kensa bilong bros na ol arapela sik moa, tasol ol lain i no save smuk tu i kisim dispela sik long wanem ol i save pulim win nogut i gat pison long ol lain i smuk klostu long ol.

Ol lain olsem Air Niugini i putim tambu pinis manmeri i smuk long ol ron bilong balus bilong en long kantri na ovasis.

Long las yia, Nesenel Geming Bod i bin putim tambu long ol manmeri i noken smuk long ol ples bilong pilai

poka masin long ol. Dispela lo em ol bai go hetim long neks mun:

PNGMS i tok wanpela bikpela wari em i gat tu em long PNG nau, moa yangpela manmeri i wok long smuk.

Dokta Sapuri i tok wanpela stadi o wok painimaut i soim olsem long PNG, moa long 35 pesen mak bilong ol yangpela manmeri i wok long smuk, na dispela em i nogut tru na bai kamapim birua long ol yangpela manmeri na kantri.

Ripot i tok planti manmeri i save smuk long wanem ol papamama i save salim ol long baim na tu, laitim smuk.

Dokta Sapuri i tok Tobako Ekti i stap pinis i givim pawa long Helt minista long putim tambu long ol manmeri long smuk long ol pablik hap.

Na em i tok bai gutpela moa sapos Helt minista i yusim dispela pawa na go hetim dispela tambu long wanem pasin bilong smuk em i namba wan as long kisim sik kensa, ol sik long lewa, blut i ron hariap, bagarapim ol sampela hap bilong bodi olsem kru, sik long skin na moa.

Dokta Sapuri i tok tru, nesenel na sampela provinsel Helt dipatmen i kari-maut ol awenes wok long tokim pablik long ol birua we smok i kamapim, pablik i no harim.

Buai kamapim kain kain hevi

PLANTI sik kensa long maus na dai i wok long kamap long Papua Niugini (PNG) long wanem long pasin bilong kaikai buai.

Na i mobeta long Dipatmen bilong Helt na ol atoriti i wokim lo long bosim pasin kaikai na salim buai long biktaun. Long wankain taim, i mobeta long salim ol kumu na ol gaden kaikai we bai helpim bodi bilong man na i no kamapim bagarap long em olsem buai na smuk.

Dispela em ol toktok bilong Presiden bilong PNG Medikel Sosaiti, Dokta

Mathias Sapuri.

Long wanpela ripot we PNG Medikel Sosaiti i gat long en, samting olsem 2000 manmeri long PNG i save bagarap long ol sik olsem kensa long naus, nek, bek i pen, sua long bel, haijin i no gutpela na moa long wanem long pasin bilong kaikai buai.

Dokta Sapuri i tok antap long ol sik we pasin bilong kaikai buai i save kamapim, em i save kamapim planti pipia long ol taun na biktaun olsem Mosbi. Na tu, apim sans long manmeri long kisim sik TB long dispela kantri.

OC i gat sik AIDS wokples polisi

PAIT agensim sik AIDS long dispela kantri i kamap pinis long bikpela opis i save putim was long ol lida bilong kantri, Ombudsman Komisn (OC).

Opim bilong AIDS Wokples Polisi em OC i bin holim long las wik Fraide. Aninit long dispela polisi, komisn bai

lukaitim menesmen na wok bilong banisim ol woklain bilong em agens long sik AIDS.

Sif Ombudsman, Chronox Manek, i tok komisn i bin mektok promis long Wol AIDS De las yia Disemba olsem komisn bai kamapim AIDS wokples polisi bilong lukaitim ol

wok manmeri bilong em.

Em i tok olsem dispela polisi bai givim kliapela stia long Komisn bilong stretim ol hevi we sik AIDS i kamapim long wokples, na stopim long kalap i go long ol wokmanmeri na ol famili bilong ol narapela manmeri.

Plis opim Tigi helt senta gen

SINGAUT i go long Luteran Sios long opim gen helt senta long Tigi insait long Dei distrik, long Westen Hailans provins.

Dispela helt senta i bin pas long las yia Disemba taim sampela man i het longlong long spakbrus i bin kilim dai

pikinini bilong wanpela helt senta wokman. Bihain long dispela ol woklain i bin lusim wok na helt senta inap nau.

Nau, samting olsem 10,000 manmeri long hap i painim hat long lukim dokta na kisim marasin na Maun Hagen em longwe tumas.



Meri Bogenvil helpim meri Fiji painim man Fiji

SHP gavman sapotim ol meri

Timon Henry i raitim

Veronica Hatutasi i raitim

KLOSTU 6-pela yia nau Maloni Namoli, wanpela pastaim soldia bilong Fiji, i stap long Bogenvil wantaim papa bilong kwik mani skim U-Vistrak, Noah Musingku.

Long olgeta dispela yia Mista Namoli i stap long ples Tonu long sautwes Bogenvil, famili bilong em long Fiji i wari. Ol i ting em i dai pinis.

Mista Namoli i bin wanpela bilong 8-pela pastaim soldia bilong Fiji, husat i bin go long Bogenvil long Septemba 2004 long kisim U-Vistrak mani bilong ol. Tasol taim tripela ol poroman bilong em i go

bek long Fiji long 2005 na narapela 4-pela i go bek long Fiji long 2007, em i no lusim Tonu, na Musingku na ol lain bilong Musingku. Fiji Hai Komisin long Mosbi i askim gavman long Buka long askim Mista Namoli long lusim Tonu na go bek long Fiji, tasol em i no harim tok.

Em i no harim tok, na famili bilong em long Fiji i no harim wanpela toksave long em...inap Rose Pihei, meri bilong lleksen Menesa bilong Otonomes Rijen bilong Bogenvil, Mathias Pihei, i go long wanpela kibung bilong ol manmeri bilong Pasifik rijen long Sidni (Sydney), Australia.

Long dispela kibung we i bin kamap bipo long Krismas las yia,

Misis Pihei i bungim wanpela tambu man bilong Mista Namoli.

Pastaim long dispela tambu man i bin kam long dispela kibung long Sidni, meri bilong Mista Namoli i bin askim em long traim askim long askim ol manmeri bilong Papua Niugini (PNG) husat i kam long dispela kibung na askim sapos man bilong em i stap laip yet o dai pinis?

Taim tambu man bilong Mista Namoli i bin bungim na askim Misis Pihei dispela askim, na Misis Pihei i bekim olsem, "Yes, Namoli i stap laip yet," tambu man bilong Mista Namoli i amamas tru.

Tasol amamas bilong em i no winim amamas bilong meri na

famili bilong Mista Namoli taim em i bin ring long telepon long ol na tokim ol dispela gutpela nius.

Namel long toktok na krai bilong tambu man bilong Mista Namoli long Australia na meri na famili bilong Mista Namoli long Fiji, em i givim telepon namba bilong U-Vistrak opis long Tonu. Kwiktaitim, meri na famili bilong Mista Namoli i ring long telepon i go long em long Tonu, na ol i pulim toktok, krai na lap bilong ol. Tasol taim ol i askim Mista Namoli long go bek long Fiji, em i tok, "Bai mi kam bihain."

Misis Pihei i tok olsem em i amamas long wanem em i go long stap long kibung tasol em i helpim wanpela meri painim man bilong em na ol na ol narapela famili i amamas.

I GAT bilip olsem Gavana bilong Sauten Hailans, Anderson Agiru, na ol memba bilong wanwan ilektoret long provins bai sapotim ol meri long kirapim wok bilong ol.

Presiden bilong ol Meri long Sauten Hailans provins, Dorothy Huku, i tok as bilong dispela wokbung em long painim aut wanem ol hevi i wok long kamap long laip bilong ol meri na tu long strongim wokbung long olgeta 8-pela distrik long bungim 2008 na 2012 rol aut program.

Ol meri presiden bilong 8-pela ilektoret i bin bung long Mendi long kamapim namba wan kibung bilong ol long dispela yia long dispela wik.

Misis Huku i askim olgeta meri long kibung long wokbung wantaim em long kamapim sampela senis long ol distrik.

Em i tokim ol meri long lus tingting long politik na wok wantaim.

STAIL BILONG INDIA

DANIS: Sampela meri na wanpela man husat i save danis wantaim Abhinava Danis Kampani i mekim wanpela danis ol i kolim 'Rasaleey' we i stori long God bilong ol Hindu, Lord Krishna. Ol i mekim dispela danis long biktaun Bangalo (Bangalore) we i stap long saut bilong kantri India long Januəri 27. Dispela danis em Nirupama na Rajendra i kamapim. -

Foto: AAPI/EPA/JA GADEESH NV



Senis i mas kamap long lewa

Save i Ken Helpim

Dispela wik, bai yumi lukluk long sampela samting yumi mekim o kaikai we i ken bagarapim kru bilong yumi. Yumi ken lukim na traim abrusim ol dispela samting.

1- I no kaikai long moning Mak bilong suga long blut bilong ol manmeri husat i no kaikai long moning bai i stap daun-bilo. Hevi bilong dispela em kru no inap kisim inap kaikai long mekim wok o wok gut. Dispela bai mekim hat long ol manmeri long tingting tu na wok. **Moa neks wik...**

Veronica Hatutasi i raitim

"SENIS i mas kamap insait long lewa bilong ol man. Dispela bai helpim daunim pasin bilong ol long paitim ol meri."

Em bilip bilong Susan Setae, meri husat i go pas long meri grup, Papua Hahine.

"Pasin tumbuna long planti hap-bilong Papua Niugini, i luksave olsem man i

bos. Dispela pasin em strong tru, na dispela pasin em wanpela as ol man i save pilim olsem em i orait long ol long paitim ol meri.

"Sampela senis i mas kamap long lewa na spirit bilong ol man sapos PNG i laikim dispela pasin long stop," Misis Setae i tok.

Grup o oganaisesen bilong Misis Setae i bin kirap long yia 2003. Astingting bilong dispela grup em long daunim hevi na birua we ol

meri na pikinini i save bungim - moa yet ol dispela we ol man i save mekim nogut long ol. Grup i save skulim ol manmeri olsem ol man na meri i gat ol wankain rait.

Long dispela taim, Papua Hahine i wok wantaim Famili Sapot Senta long helpim ol meri, mama, ol pikinini meri na ol arapela manmeri husat i bungim hevi na birua long pasin bilong paitim na mekim nogut long wanpela narapela in-

sait long famili.

Misis Setae i tok olsem tru planti wok awenes na sanapim ol lo, taim na wok i go insait long daunim pasin bilong paitim na mekim nogut ol meri na pikinini. Tasol dispela pasin i wok long kamap bikpela.

"Dispela em long wanem i nogat strongpela lo o karimaut bilong dispela lo na mekimsave long ol lain husat i brukim dispela lo. Olsem na mi tok, senis i

mas kamap long lewa na spirit bilong man, em bai yumi lukim senis," em i tok.

Insait long wanpela mun Famili Sapot Senta i save helpim 31 mama na pikinini i gat ol hevi long famili. Samting olsem 14 meri na mama i save kisim kaunsiling long wanpela wik. Wanpela mama o pikinini meri i save slip long senta long wanpela de. Na insait long 6-pela mun, senta i save helpim klostu long 200 meri, mama na pikinini.



OFFICE OF HIGHER EDUCATION ANNOUNCEMENT ENROLMENT AT PAPUA NEW GUINEA'S 39 DECLARED INSTITUTIONS OF HIGHER EDUCATION IN 2009

22nd January 2009

This announcement is intended for the general public about opportunities for college experience in the 39 declared institutions of higher education and academic and training programs on offer that are recognized by the government through the PNG Commission for Higher Education (PNGCHE). Twenty one of the institutions are also recognized by the Education Board and the Medical Board.

Declared institutions of higher education include universities and two year colleges that are either fully or partially funded by the national government through the Annual Budget Appropriations. Funding is through direct transfers to the six universities and statutory institutions, through the Office of Higher Education or through Education Department and the Health Department in case of the 21 two year colleges under the Education Board and the Medical Board.

The PNG higher education is governed by the Higher Education Act (1933 as amended 1998, 2004). The University of Papua New Guinea Act, the PNG University of Technology Act, the University of Goroka, University of Vudal, the Divine Word Institute Act, the Pacific Adventist University Act, the Maritime Training Institute Act, Legal Training Institute and the Institute for Business Studies are the statutory basis for individual higher education institutions. The Education Act defines Technical and Primary Teachers' Colleges as part of the National School Education System. It gives the Secretary of School Education authority to award certificates and diplomas. Acts defining academic prerequisites for registering technicians and professionals in the health sector include the Medical Registration Act for nurses and paramedics.

The PNG Commission for Higher Education (PNGCHE) is committed to the diversity of providers of higher education and access to opportunity. It hold in the highest regard policies and principles that guarantee open and tolerant scholarship, an exchange that is vigorously protected and defended through the national quality assurance system and academic autonomy of the faculty.

Academic freedom informs the entire academic community: the free exchange of ideas applies to students choosing a course of study, to faculty pursuing scholarly research and teaching, and to institutions admitting students, appointing faculty, and setting standards. A condition of mutual respect enables the existence of these many-faceted scholarly discourses.

The PNG higher education system, as true to its academic ideals, treats each institution as unique individuals worthy of respect, to be judged solely

by their actions, intellect, character and capacity to sustain its programs. An institution of higher education does not stereotype its members; it does not permit them to be put into categories based on suspicion, ignorance, deceit or prejudice; it does not deny to any of its members the full rights of academic freedom and engagement. The PNGCHE is vigilant and in 2008 strengthened the processes of institutional establishment, accreditation, and declarations of existing institutions as universities. In 2009 it will review all course offerings it supports through the TESAS and reclassify each into four development types. And therefore given the special dedication of the governors, administrators, staff, and students of the 39 Institutions of Higher Education, government has every confidence in the continued success of its declared tertiary institutions provided hereunder:

Table 1: Universities and Parallel Affiliated/Amalgamated Colleges

UNIVERSITY TYPES	PROGRAM FOCUS	NO	AUTHORITY
Pacific Adventist University	4 year programs undergraduate, liberal arts/comprehensive	1	Statutory Authority
Sonoma Adventist College*	2 years Business, Education, Secretarial & Agriculture	1	✓
Adventist Church School of Nursing*	3 years General nursing and paramedic	1	✓
Divine Word University	4 year undergraduate to graduate level liberal arts/comprehensive	1	Statutory Authority
Lutheran Nursing School **	3 years General nursing	1	Lutheran Church
Madang Allied Sciences **	3 years Extension and Environmental Health	1	Health Department
University of Vudal	4 year limited agriculture programs at undergraduate level	1	Statutory Authority
Popondetta Agricultural college *	2 Year Tropical Agriculture	1	✓
University of Goroka	4 year teacher training at undergraduate levels/graduate	1	Statutory Authority
PNG University of Technology	4 year technology/engineering programs at different levels/some graduate programs	1	Statutory Authority
Lae Timber College *	4-10 months, wood processing sawmill management, chain saw.	1	✓
Bulolo Forestry College *	3 year Forestry Program	1	✓
University of PNG	4-year all-purpose programs at different levels, including 4 regional distance university centres/some graduate	1	Statutory Authority
Medical Faculty *	6 years undergraduate medicine, post-graduate diplomas & 2 year Masters	1	✓
Institutional type	Program Emphasis	No	Authority
Port Moresby Technical college	1 year Pre-employment & higher technical training in engineering	1	Education Board
Lae Technical college	1 year Pre-employment & higher technical training in engineering	1	Education Board
Madang Technical college	1 year Pre-employment & higher technical training in engineering	1	Education Board
Hagen Technical college	1 year Pre-employment & higher technical training in engineering	1	Education Board
Port Moresby Business College	8 - 16 months Office and business management/accounting	1	Education Board
Goroka Business College	8 - 16 months Office and business management/accounting	1	Education Board
Kokopo Business College	8 - 16 months Office and business management/accounting	1	Education Board
Madang Primary Teachers College	3 years Teachers' Training	1	Education Board



LUKAUT: Wanpela Uruguayan gaucho o kauboi i pundaun kamdaun long hos em i wok long sindaun antap long rodio long Montevideo long Trinde, Mas 19, 2008. Foto: AAP/AP/Marcelo Hernandez

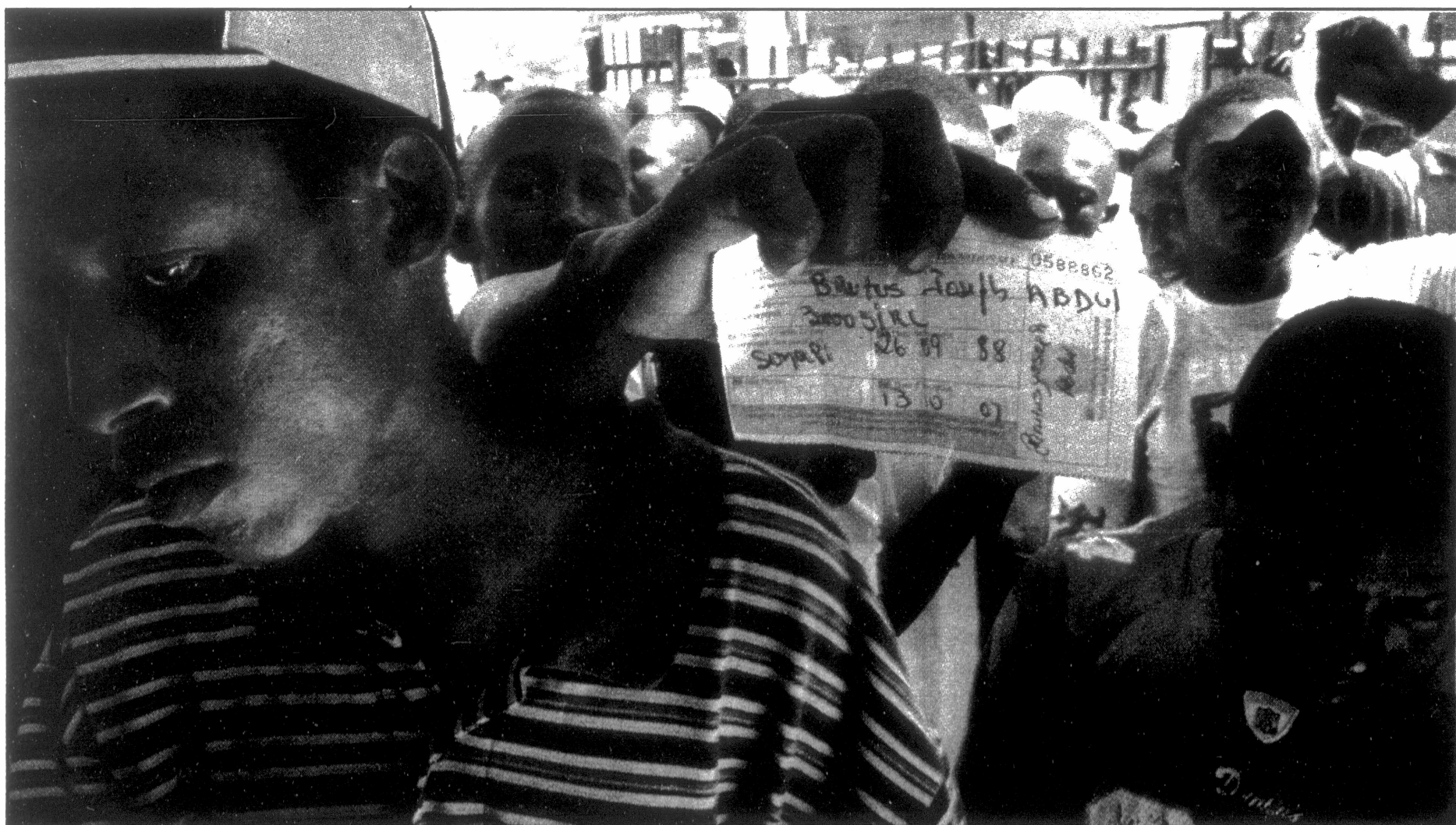

VOT: bdul Joseph Brutus i soim vota rejistresen risit bilong em long rejistresen senta bipo long ol senet ileksen ausait long Cite du Soleil long Port-au-Prince long Tunde, Febuari 10. Haiti bai holim ol senet ileksen bilong en long Epril 19. Foto: AAP/AP/Ramon Espinosa



TAIM DRAI: Wanpela fama i wokabout abrusim wit gaden bilong em we i drai pinis long ples Liuhe long Tongzhou distrik bilong Beijing, Saina (China), long Sande, Febuari 8. Taim drai i bungim planti ol hap long not bilong Saina we i save groim ol kain kaikai olsem wit. Namba tu minista bilong ol wara risos long Saipa i tok olsem ol wok bilong karim ol wara i go long ol dispela hap i kamap gut na bai i go het.

Poto: AAP/AP/Ramon Espinosa

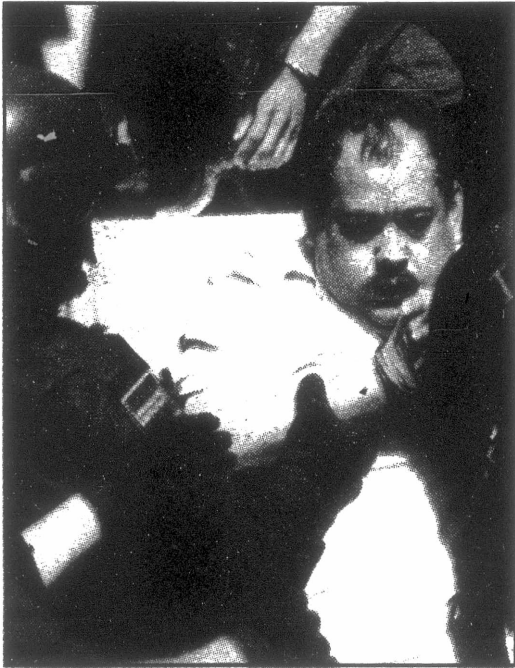

HOLIM PASIM: Polis i bilip dispela man ol i holim pasim, Alberto Martin Alamillo, i wanpela lida bilong ol raskol husat i save karimaut ol raskol pasin (stilim ol man na askim long mani, salim ol drag na olsem) bilong ol ausait tasol long biktaun Meksiko (Mexico). Dispela poto i soim polis i holim pasim Alamillo long karim em i go long wanpela bung long biktaun Meksiko yet long Tunde, Febuari 10.

Poto: AAP/AP/Dario Lopez-Mills



HELPIM: Ol manmeri i yusim ol bot na han bilong ol long traim long helpim ol dispela dolpin i go bek long solwara bihain long ol i swim i kam long hap we i klostu tumas long nambis long Manila Be long Orion, Bataan provins, 96 kilomita long wes bilong Manila, Filipins (Philippines). Dispela i bin kamap long Tunde, Febuari 10.

Poto: AAP/AP/Bullit Marquez

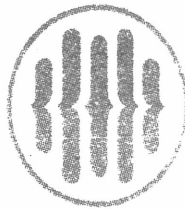

TELIKOM PNG LIMITED
Always there!

Unbeatable Offer Fixed Lines Rates Slashed!

"IT ONLY TAKES AS MUCH AS A PHONE CALL THIS VALENTINES..... IN FACT AS MUCH AS"

♥ **20t** Postpaid Untimed Local Calls

♥ **17t** Prepaid National Calls for first five minutes

♥ **33t** per min Prepaid Calls for Adjoining Zones

♥ **50t** per min Prepaid calls for non Adjoining Zones

♥ **49t** per min to BMobile

♥ **50%**

OFF STD & IDD Calls

Terms of Conditions
Changes apply to on-net Telikom PNG & BMobile calls only
This is a promotional offer valid to 14th Feb, 2009
Rates apply to both off-peak and peak times
Prepaid tariffs apply to Rait Prepaid and Telikod services only

I kam long Pes 8

Dauli Primary Teachers College	3 years Teachers' Training	1	Evangelical Alliance
St. Benedict Primary Teachers College	3 years Teachers' Training	1	Amalgamated with DWU
Balob Primary Teachers College	3 years Teachers' Training	1	Lutheran Church
Kabaleo Primary Teachers College	3 years Teachers' Training	1	Catholic Church, Diocese of Rabaul
Holy Trinity Primary Teachers College	3 years Teachers' Training	1	Catholic Church, Diocese of Hagen
PNG Education Institute	In-service College for Education staff & 3 years vocational teacher training	1	Education Board
Mendi School of Nursing	3 years General nursing	1	Medical Board
Goroka Highlands School of Nursing	3 years General nursing	1	Medical Board
Lae School of Nursing	3 years General nursing	1	(affiliated with PNG University of Technology)
St. Mary School of Nursing - Vunapope	3 years General nursing	1	(affiliated with DWU)
Nazarene School of Nursing - Kudjip	3 years General nursing	1	Nazarene Church
Fisheries college	1 - 10 months course in tropical Fisheries	1	National Fisheries Authority/University of Vudal
Maritime College	2-3 years Ship navigation and engineering officer	1	Statutory Authority
PNG Institute of Public Administration	4 months - 10 months development administration & extension	1	Statutory Authority
Legal Training Institute	1 year post LL.B. Internship	1	Statutory Authority
Institute for Business Studies	8 - 16 months Office and business management/accounting	1	Private/ Statutory Authority

Notes: * External Campus of University, ** Affiliated College, / governed by same authority.

TERTIARY EDUCATION SCHOLARSHIPS ASSISTANCE SCHEME (TESAS). The 2009 AWARDS

The TESAS policy is a financial assistance scheme to support Papua New Guinean citizens who satisfy the basic requirement of 1.6 to 4 on the National Grade Point academic Average on the grade 12 national examinations and the internal universities and two year colleges end of year assessments. It is a merit - excellence based programme.

TESAS is the policy instrument of the User Pays Policy of the state. TESAS supports student learning by subsidising accommodation, meals, utility (water/power) prescribed course materials and return travel from home of upbringing to the institution. It is not additional budget to the higher education operational and salaries budget appropriated by government on annual basis. The fund is managed by the Office of Higher Education for the TESAS scholars.

The TESAS budget and awards from 2000-2009 is shown in the following chart.

Awards

The Government Component for University students is:

1. K4,670 per student for the Academic Excellence Scheme
2. K 3,770 per student for the Higher Education Contribution Assistance Scheme
3. K525 per student for Loan for students on the HECAs who need to additional support.

Government Component for non university students is:

1. K 2.613 HECAS
2. K925 for Loan

Self Sponsoring Students can take loan of K2250 in any year.

The kina value of the TESAS Policy i.e., candidates who are satisfying the TESAS policy (1.6 - 4 GPA) is insufficient owing to rise in high GPA scores by continuing students increases and student from the fast expanding secondary school system.

To increase the benefits to as many students, the OHE did away with the AES for new intakes, non university institutions and some social sciences programmes. This allowed the increase in the number of high performing students.

The change in awards as informed by trends over the last five years shows increases in high GPA scores above the 1.6 threshold. The following chart shows this trend.

The student population for the grade 12 school examination is centred around the mean of 2.2957 or the numerical average GPA. The spread or variation of the GPA values around the mean, or the standard deviation is 0.34426, a narrow variation.

Comparatively, the standard normal distribution has a mean of zero and standard deviation of 1. This means that more data is tightly

packed (or students with GPA 2.3) around the mean value of 2.3. However, with a skewness of 0.059, more GPA scores lie above the mean!

What this means is that 80% of students for one particular year scored above a GPA of 2.0, and 98% of students scored above 1.6. Therefore the TESAS award favours high performing students.

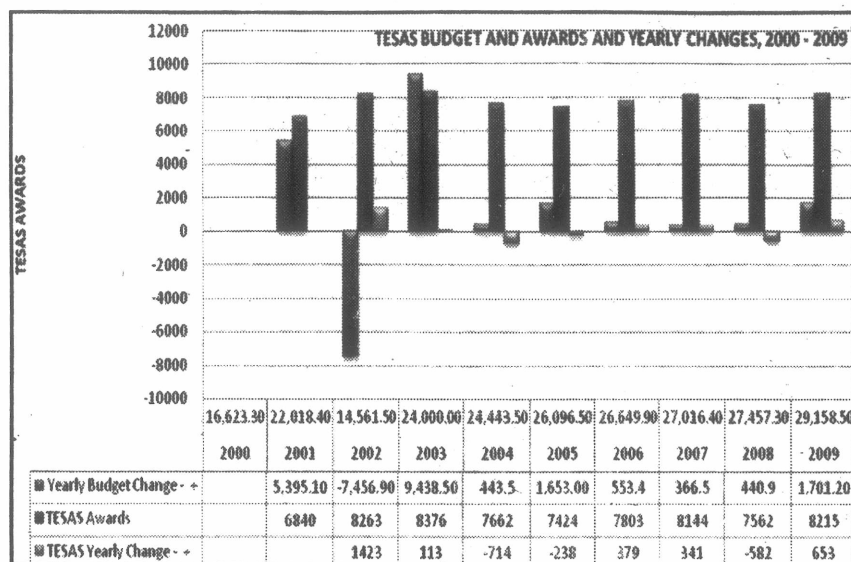

The TESAS Program has not changed for 2009. The admissions policy remains at 1.6 GPA. TESAS awards Institutions of higher education have adopted this as the minimum requirement for admission to universities and colleges. Some institutions and programs require higher GPAs. Institutions who have in the past considered GPA lower than 1.6 are reviewing their minimum entry requirements.

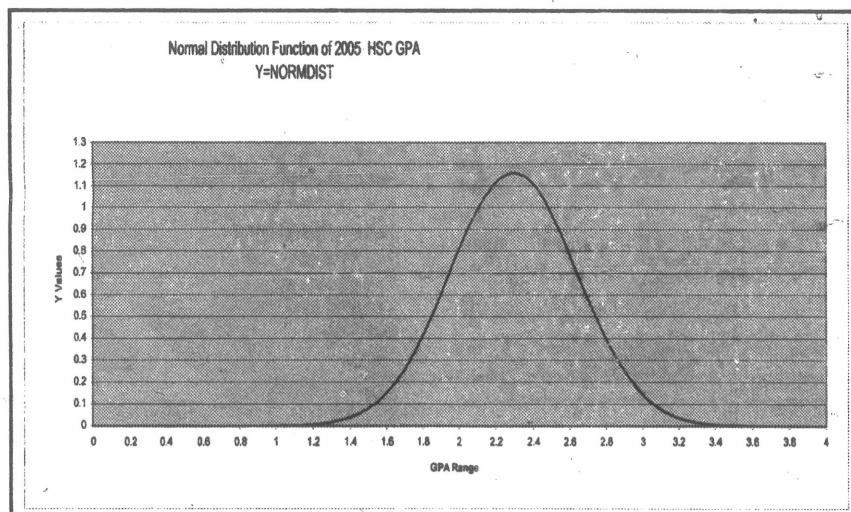

Some institutions have developed entry tests.

The OHE is working on a Standard Admissions Test (SAT) to bridge the gap between excellence and equity based on needs for populations from poor social economic and disadvantaged communities. SAT is expected to inform scholarship deficiencies and intellectual excellence in determining future scholarship considerations.

Authorized by:

Dr. William G Tagis, PhD
Director General - Office of Higher Education

2nd Floor
 Mutual Rumana Building
 Waigani Drive

P O Box 5117
 Boroko 111, N.C.D
 Papua New Guinea

Tel: (675) 301 2051
 Fax: (675) 325 8386
<http://www.ohe.gov.pg>



TOK PISIN NEWS
from Radio Australia

radioaustralia.net.au

Harim TOK PISIN long
Radio Australia
101.9FM
Port Moresby

Tok Pisin Service

6am - 7am 6080; 7240(KHZ)

7pm - 9pm 5995; 6020; 9710; 1280(KHZ)

Join UN Komonwelt tim i bung wantaim ol Fiji politisen

Wanpela join Yunaitet Nesens (UN) Komonwelt tim bai i go het long bung wantaim ol Fiji politisen long Tunde, long stat long redim program long ol politikel toktok i kamap long stretim rot long kantri long holim demokratik ileksen gen.

Pacific niusman Campbell Cooney i ripot olsem long Mande, dispela ol ripot, join UN, Komonwelt tim i bin bungim SDL politikel pati bilong Laisenia Qarase, husat i bin praim minista taim Komodo Frank Bainimara, i bin rausim em long 2006 ku.

Mista Qarase i tok na ol wan lain bilong em i bin toksave gut long dispela UN Komonwelt tim long as em i bikipela samting long rediim politikel toktok kwik-taim, tru ol i no makim de long ol toktok.

Dispela 5 memba tim bai i toktok wantaim olgeta manmeri i stap insait long Fiji politik pastaim long em bai i bung wantaem ol man bilong militari o ami em i sapatim intarim gavmam long pinis bilong wik.

Polis long India i holim pasim pinis bosman o Hizbul Muja-hedin

Polis long India i tok ol i holim pasim pinis bosman o "operational chief" bilong ol lain ol i holim Hizbul Mujahedin, em bikipela rebel fos long Kashmir.

Wanpela mausman blong polis i tok ol i bin holim kalabus Muzaffer Ahmed Dar long wanpela ples em i save hait long en long Indian Kashmir biktaun Srinagar.

Em i tok long dispela man, krismas blongem, tripela-ten-eit (38) olsem i wanpela long ol lida bilong pro-Pakistan grup em ol i laikim tru long painim na kalabusim, ol i bilip olsem em i bin go pas long ol kain teroris pait na wok.

Long em i kalabus nau, ol i lukim olsem em i nogut nau long Hizbul Mujahedin, em i save kamapim ol trabel long Kashmir - em Muslim-majoriti Himalayan stet i bruk namel long Pakistan na India - long 1989.

Ol Nu Silan paia paita i stap sambai

Ol Nu Silan New Zealand paia paita nau i stap sambai, wetim toktok long sapos bai ol i go long Viktoria (Victoria) long halivim stopim ol bus paia em i kilim pinis planti manmeri long Australia.

Niusmeri long Nu Silan, Kerri Ritchie i ripot olsem Praim Minista bilong Australia, Kevin Rudd i oraitim pinis ofa bilong Nu Silan long salim 100 paia paita.

Nu Silan rurel paia opisa Murray Dudfield em i wetim nau fomol askim em bai i kam long gavman bilong Viktoria, em bai i tokaut klia long wanem kain halivim ol i laikim.

Em i tok ol Nu Silan paia paita i gat gutpela save long paitim o stopim paia long ol bikipela paia long bus na ol i laik halivim.

Ol Nu Silan paia paita i bin halivim Australiatu long stopim paia bipo long 2007.

Wanpela-ten-wan long ol i bin kisim bagarap long bodi blong ol taim paia i bin raunim ol klostu long mansfield long Viktoria.



PAIRAP NA PAIA

BIRUA: Ol kar i paia long hap we wanpela bom ol man nogut i putim long wanpela kar i pairap long biktaun Madrid long kantri Spain, long Mande, Febuari 9. Polis i tok olsem nogat manmeri i kisim bagarap long dispela birua. *Poto: AAP/AP/Amaya B*

Papua Niugini bai save long dispela yia sapos agrimen i kamap orait

Gavman bilong Papua Niugini (PNG) i tok, em bai save, sampela taim long dispela yia, sapos em agrimen i kamap orait long dispela 12 bilion US dola liquefied natural gas projek.

National niuspepa i ripot olsem, ol opisa i makim sampela long bikipela eksport kredit ajensi long wol i stap pinis long PNG long painim aut sapos politik long i strong na sapos ol papagraun bai sapatim dispela projek.

PNG i tingting bilong makim ol maket long Esia olsem Siapan (Japan), Korea, Saina (China) na India, we i gat bikipela laik tru long enesi na we ol inap salim LNG long bikipela prais.

Deputi Praim Minista and Minista bilong Lens na Maining, Dokta Puka Temu, i tok, bai ol i paitim toktok long benefit sharing arrangements wantaim ol papagraun olsem hap bilong bilion dola projek.

Em i tok, ol join vensa patna raun long wol em ExxonMobil i bin go pas long en, bai holim toktok long maket na traim long mekim ol i stap insait long agrimen inap long 30 yia.

Namba bilong ol manmeri i dai long bus paia i go antap moa

Moa long foa-tausan ol paia paita i kam long olgeta stet na teritori long Australia i wok long traim long stopim paia long Viktoria (Victoria) long Australia.

Polis i bin kandim gen namba bilong ol manmeri i dai pinis long paia long stet na nau em i go antap long 171.

Long nau tripela ol komyuniti o taun long not is long Melbon Melbourne siti, paia i wok long kamap ron i go klostu long ol.

Kantri Paia Atoriti i tok namba bilong ol manmeri bai ol i painim ol i dai long paia bai i go antap moa yet.

Stet Duti Opisa, Tony Bearzatto i tok oli bin painim ken sampela moa ol dai-bodi long sampela ol hap em paia i bin kamap long en.

Nu Silan Foren minista i go lukluk raun long Samoa

Nu Silan (New Zealand) Foren minista, Murray McCully i tok, tupela de lukluk raun bilong em long Samoa i bilong strongim ol wokpren namel long ol lida bilong tupela kantri.

Mista McCully bai lusim Apia tete (trinde) na bai bungim Samoa praim minista, deputi praim minista na sampela ol narapela bisnis

na komyuniti lida long hap.

Em i tok, insait long ol toktok, ol bai paitim ol toktok long ol hevi insait long rijenel, ol spesel forum lida meeting long bihainim-taim bilong Fiji, bai wanpela long ol na na hevi ol wokmani bihainim ol hevi bilong ol wok mani raun long wol nau.

Mista McCully i tok, ol bai toktok long wanem we Nu Silan i ken helpim ol praivet bisnis long gro insait long Samoa.

Ol wol lida i salim bikipela bel sori

Australia Praim Minista i tok ol lida raun long wol i autim bikipela tok sori blong ol long ol viktim blong dispela bus paia long Viktoria.

Kevin Rudd i tok em i bin kisim ol telepon kol i kam long ol lida wantaim tu Jenerel Sekreteri bilong Yunaitet Nesens, Gret Briten, Yunaitet Stets bilong Amerika, Teki na Nu Silan.

Ol i pasim gen kwesten taim insait long tupela haus palamen bilong Australia na larim Mista Rudd long givim wanpela 'condolence speech' - bel sori toktok - insait long House of Representatives.

Em i tok US Presiden, Barak Obama i bin wanpela long ol i ringim tete moning.

Pacific BEAT

4, 5, 6am & 4pm, 5pm including sport

Listen to Radio Australia 101.9FM Port Moresby

Radio Australia current affairs programme which focuses on island nations, bringing you morning and evening coverage of Pacific current affairs including interviews with political leaders, newsmakers, and the people who make the Pacific beat.

YUMIFM Radio Program

Program bilong Wanwan De - Mande - Fraide

- 6am - 10am - Sankamap show - Host: KAS.T
6:15am - Komuniti Notis Bod
6:30am - Nius Hetlains / Bondei gritingis
Trukai Rais - GES FAIA KOMPETISEN
6:45am - Niuspepa Hetlains
7:00am - Major Nius Bulletin - YUMIFM Nius Senta
7:15am - Toktok sapotim LO na JASTIS Sekta
7:30am - Trukai Rais - GES FAIA KOMPETISEN
8:00am - Major Nius Bulletin - YUMIFM Nius Senta
8:15am - Stori b'long Skelim Tingting
8:30am - Trukai Rais - GES FAIA KOMPETISEN
9:00am - Nius Bulletin - YUMIFM Nius Senta

- 9:15am - Luksave long Komuniti (Radio Pilai)
9:30am - Trukai Rais - GES FAIA KOMPETISEN
9:45am - YUMI PAINIM WOK Segment
10:00am - Nius - YUMIFM Nius Senta
10am - 2pm - Monin Trek na Belo Pack - Host: VAVIESSIE
10:10am - Lukatim yu yet - Helt toktok - RH Hyper Mart
10:45am - YUMI PAINIM WOK Segment
11:00am - Nius - YUMIFM Nius Senta
11:10am - Con'd - Lukatim yu yet - Helt toktok
11:30am - Nius Hetlains b'long Belo Taim
12:00pm - Major Nius Bulletin - YUMIFM Nius Senta
12:10pm - BELO Taim - wantaim sapot b'long TELIKOM
12:15pm - Komuniti Notis Bod
12:20pm - BELO Taim - wantaim sapot b'long TELIKOM
1:00pm - Nius - YUMIFM Nius Senta
1:10pm - BELO Taim - wantaim sapot b'long TELIKOM
2:00pm - Major Nius Bulletin - YUMIFM Nius Senta
2pm - 6pm - Avinun Draiv Taim - Host: Enjo Dabix
2:00pm - 4:00pm (Tundei / Fondel) TOKAUT TOKSTRET

- 2:45pm - YUMI PAINIM WOK Segment
3:00pm - Nius - YUMIFM Nius Senta
3:10pm - Avinun cruz
4:00pm - Nius - YUMIFM Nius Senta
4:10pm - "FOAPELA KAM GUD LONG 4"
4:30pm - Nius Hetlains
4:45pm - YUMI PAINIM WOK Segment
5:00pm - MAJOR NIUS BULLETIN - YUMIFM Nius Senta
5:10pm - 6:00pm - FLAME KULCHA (1 hr) listeners request
6:00pm - MAJOR NIUS BULLETIN - YUMIFMNIUS Senta
6 - 7pm - Maggi noodles request aus
6pm - 00am - NAIT BEAT - Host: ANGRA KENNEDY
6:10pm - 7:00pm Mun kamap sho
6:45pm - Komuniti Notis Bod
7:00pm - 9:00pm - COCA COLA GARAMUT
9:00pm - 00am - Nait Beat - Iei Cruz long nait
00am - 6am - BRUKIM TULAIT SHOW - Host: Papa Raegs / Sally / Nenge
00:00 - Early Monin Taim Cruz (of lain brukim tulait shift)

- Musik / Request / Tok pilai
Kipim Kampani long oi nait shift
Weekend Shift - Saturday & Sunday
6:00am - 11:00am - Wilen Sarrais
6:30am - Komuniti Notis Bod - Bondei gritingis
7am - 9am - Wilen Spots
9am - 11am - Monin Raun
11am - 1pm - National Weekly Hit Parade (Host Kas.T)
2pm - 6pm - Sarere Avinun Draiv
6pm - 00am - Nait Beat (Host Angra Kennedy)
YUMIFM POROMAN TEAM:
Tuner (KAS.T) Arifae - Team Leader / Program Director
Angra KENNEDY - Senior Announcer
Sinimil (Vaviesie) Philipo - Promotions Co ordinator
Papa Raegs - Announcer Nenge Neings - Announcer
Enjo Dabix - Announcer Selestine Sally Sino - Announcer

Raun wantaim Wantok

1. PASIN TUMBUNA I NO DAI: Hia ol pikini long Komiufo long Goroka, Isten Hailans provins i bilas long tumbuna bilas na redi long danis long wanpela bikpela bung bilong ol. Pasin tumbuna i no dai long ples yet.

Poto: James Kila

2. OL DRAMA BOI: (poto daunbilu) Hja ol pikinini bilong 8 Mail i lainim we bilong pairapim dram. Ol Dijisel (Digicel) lain i bin go long 8 Mail na lainim ol pikinini long musik. Poto: Veronica Hatutasi



93.1FM YUMIFM NATIONAL WEEKLY HIT PARADE. SPONSOR: DIGICEL. Produced & Hosted by: KAS.T. STATISTICS. PAPA RAEKS & YUMIFM POROMAN CREW. Date Ending: Saturday: 31st January 2009. Table with columns: W/B, L/W, T/W, SONG, ARTIST.

RADIO AUSTRALIA TOK PISIN PROGRAM HARIM LONG: 101.3 FM. Radio Australia Tok Plain Program - MANDE. Moning - Nait. TUNDE. TRINDE. FONDE. FRAIDE. SARERE. SANDE.

EM TV TV GAID

FONDE FEBRUERI 12, 2009. 5.29AM STATION OPEN. 5.30AM G TODAY. 9.00AM EMTV PRIME TIME LINE UP. 2.59PM STATION OPEN. KIDS KONA. 3.00PM G G2G: GOT TO GO. 3.30PM G THE KINGDOM OF PARAMITHI. 4.00PM G SHARKY'S FRIENDS. 4.30PM G HOLLY'S HEROES. 4.57PM G EMTV TOK SAVE. 5.00PM G THE SHAK. 5.29PM G EMTV NEWS UPDATE. 5.30PM G HOT SOURCE. 6.00PM G NATIONAL EMTV NEWS. 6.30PM G A CURRENT AFFAIR. 6.59PM G NEWS UPDATE - TOK PISIN. 7.00PM G SPORTS SCENE. Award-winner host Steven Dawanincura and a panel of experts present sports news, views and interviews from PNG and abroad... plus all the pre-seasons NRL news! **ALL NEW** 7.30PM G ELITE MUSIC ZONE

EMTV's Severina Kaumu presents the latest music clips from overseas and PNG. **ALL NEW** 8.30PM PG AFTERBURN. 9.00PM M GREY'S ANATOMY. Award-winning drama - The doctors of Seattle Grace Hospital deal with life-and-death consequences on a daily basis - it's in one another that they find comfort, friendship and love. Together they're discovering that neither medicine nor relationships can be defined in black and white. Real life only comes in shades of grey. **SERIES PREMIERE** 10.00PM M ENCORE PRESENTATION: ARMY WIVES: "A Tribe Is Born". A new television drama series that follows the lives of four army wives, their families, and an "army husband" whose wife is in the army. 11.00PM G EMTV NEWS REPLAY. 11.30PM Australia Network. FRAIDE FEBRUERI 13, 2009. 5.00AM G JOYCE MEYER. 5.30AM G TODAY.

9.00AM EMTV PRIME TIME LINE UP. 1.00PM G ONE DAY SERIES (Live) AUSTRALIA vs. NEW ZEALAND. Venue: Gabba, Brisbane. 5.00PM G THE SHAK. 5.30PM G AUSTRALIA vs. NEW ZEALAND continues... 6.00PM G NATIONAL EMTV NEWS. 6.30PM G AUSTRALIA vs. NEW ZEALAND continues... 8.57PM G EMTV TOK SAVE. 9.00PM G SUPER 14: HIGHLANDERS V BRUMBIES. All the action of the Rugby Union Super 14 from Dunedin, New Zealand. 11.30PM Australia Network. SARERE FEBRUERI 14, 2009. 11.59AM STATION OPEN. 12NOON G THE SHAK. 12.30PM G BOARDING PASS. Surf, skate, snow and travel show. 1.00PM G AUSTRALIA'S GREATEST ATHLETES. Hosted by Andrew Voss and Michael Slater with guest host Ricky Ponting.

who put 8 of Australia's greatest athletes through 15 challenges over 8 weeks, from Sanctuary Cove, Queensland. 2.00PM G TOTAL RUGBY. News and reviews of the rugby competition around the world. 2.30PM G SUPER 14: CRUSADERS V CHIEFS. 4.30PM G FISHING NORTH AUSTRALIA. Alex Julius and his team are back on the water and into the fish across the world's best wild angling action. From chasing barra, sport fishing and reef favourites from the Arnhem Land coast to tidal waterways, tune in for top fishing action, great tips and adventure. 5.00PM G SPEED MACHINE. 5.30PM G MXTV. In Part 2, USA Reporter, Malcolm McCassy is set loose at the San Diego SX. He brings us all the action from the track and the pits before the race. He catches up with all-round freak, Travis Pastrana, SX veteran Kevin Windham, and much, much more... 6.00PM G NATIONAL EMTV NEWS. 6.30PM PG AUSTRALIA'S FUNNIEST HOME VIDEO SHOW. 7.27PM EMTV TOK SAVE.

8.00PM PG THE SIMPSONS. 8.00PM G SUPER 14: HURRICANES V WARATAHS. EMTV's Severina Kaumu presents the latest music clips from overseas and PNG. **ALL NEW** 10.30PM M THE MUSIC JUNGLE: The hottest music show on TV includes songs, videos, interviews, tour news, music gossip and the latest clips from up-and-coming independent bands. **ALL NEW** 11.30PM Australian Network. SANDE FEBRUERI 15, 2009. 8.59AM STATION OPEN. 9.00AM G HILLSONG. Join Brian Houston every Sunday as he teaches to change mindsets and empower people to lead and impact every sphere of life. **PREMIERE** 9.30AM G TODAY ON SUNDAY. 12.30PM AUSTRALIA NETWORK. 4.29PM EMTV STATION RE-OPEN. 4.30PM PG WWE AFTERBURN.

K A V I E N G I U O N A R E T E M
 O A K O N O G O G O A P R E A N S
 L I B R U A B I L E M R E D R S B
 R A S I P N O N O P A I R P O K A
 U S E L E T R O M E T L I K N A G
 T L O F A N E K H I A S T O L S A
 A S D R U L I P I S N M R I K U T
 P R I M A N O D A N A G O L O L E
 A N G R G S A N O K I L A I W A R
 L L E S P A S M E R D N W O L V E
 U A U N I P A W A L A G N A F A K
 M M E K I L O P E B I D S O N G M
 O B E R U P O N Y U A A S O P N U
 L U L K O B U M I N M K E S N A M
 A U S T R A M U F O M N E R I O L
 M A N G A I S U D O K L U E N R K
 T P A R U A I M U A M U R U K A L

PAINIM OL DISPELA PLES LONG NU AILAN:

- KAVIENG TASKUL METERAN UMBUKUL KABIEH MANGAI
- LAKURUMAU BAGATERE KONOS MALOM SILOM NAMATANAI
- SAMO DANFU REI TARON MALIOM METLIK
- KABAMAN KING ULAPUTUR KONOGOGO LAMBU LAEFU
- PARUAI NONOPAI FANGALAWA NGAVALUS

9		2				
	2		6	8	5	7
	7	4	8		1	
4	5			1	6	3
3	7	6			5	2
	2	1	5			7
	4		1	2	3	
7	1	5	3		2	
			5			1

Oi Ansa bilong las wik Isu...

6	7	5	8	3	2	4	9
9	5	2	4	6	1	3	7
4	3	8	7	9	2	6	5
1	7	6	2	5	4	9	8
8	4	3	1	7	9	5	2
5	2	9	8	3	6	4	1
7	6	1	9	4	5	8	3
3	8	5	6	2	7	1	9
2	9	4	3	1	8	7	6

L	T	O	R	O	K	I	N	A	I	P	O	I	R	O	K
A	P	U	T	O				S							M
M	K	A						U	I						O
A	B	U	I	N	R			K							A
N															T
K				A	B			N							A
U				N	A										P
A	B	U	K	A	U										E
W	A	K	U	N	A	I									N
T	O	I	M	O	N	A	P	U	O	A					I
A	E							R		P					O
W	T	O													S
A	A	T						V	I						N
R								I	K	A	T				U
A								V	R						M
K	U	N	A	P	O	P	O	I	A	P	I	S			A

TORO

TORO EM WASWAS GUT TRI LONG MANDE MONING...

EM PUTIM NEKTAI NA MISIS EM PAOL OLGETA...

NAU MISIS! ASKIM EM...

GO LOTU LONG MANDE MONING?! ASTE SANDE YU SPAK NA SILIP DAI YA??

BIABIA

BIABIA GO PILAI POKI LONG WANDELA KLAB... TASOL I GAT TAMBU LONG SIMUK INSAYT...

BIABIA PILAI NA SIMUK I KILIM EM INSAYT.. EM SUBIM MASIS STIK LONG BATEN BILONG TO BEK NA GO ANTSAYT NA SIMUK I STAP...

NAU EM HARIA OL MANMERE SINDAUT OLSEM WANPELA MASIN I PAIRAP LONG FUL HAUS... BIABIA OPIM DUA NA SEKIM OLSEM EM MASIN BILONG EM TASOL I PAIRAP...

BAGA RON I GO INSAYT WANITAIM SIMUK LONG MAUS YET LONG PASIM MASIN.. TASOL NOGAT OL SEKURTI HOLIM EM NA RAUSIM EM..

KANAGE

KANAGE KALAP LONG PAUV NA GO SINDAIN TASOL.. EM I NO PEIM BAS FE..

BOSS KRUI SINGAUT LONG KANAGE LONG PEIM BAS FE TASOL KANAGE PRITEN OLSEM EM I NO HARIM...

BOSS KRUI EM BELHAT NA BIKMAUS LONG KANAGE...

KANAGE PRITEN LONG KURAR NOGUT NA BEKIM...

BEKIM OL DISPELA ASKIM...

ASKIM 1: Dispela em fleg bilong wanem kantri long Pasifik?

ASKIM 2: Putim gut ol dispela leta na painim aut em wanem samting dispela man i save mekim?

ASKIM 1: Solomon Alians Fleg

ASKIM 2: Kapenta

Ol bekim bilong Askim:



Baffi brukim lewa
 Baffi em wanpela dok meri husat i stap long Renbo Viles. Taim bilong ol dok man long painim ol dok meri na olgeta dok man i go raun long haus bilong Baffi. Planti nois tumas long nait na papa bilong Baffi i les. Em singautim tambu man bilong em husat i stap long Waigani long kam na karim Baffi i go long hap. Long apin-un, taim tambu kam karim baffi i go, olgeta dok man husat i stap long kompaun i paul. Ol i kam raun long haus bilong Baffi na painim Baffi tasol meri i no stap. Bikpela

krai kamap long haus. Wari kilim olgeta. Sampela pundaun long graun na tanim tanim na krai. Papa bilong haus kamaut na bikmaus long olgeta na ol i lus wanwan.

Kaikai tit
 Blekaut klostu klostu i mekim ol manmeri i les pinis long PNG Pawa. Wanpela famili i wok long lukim DVD bilong "Passion of Christ" na ol i wok long kaikai tit i stap long hap we ol soldia i wok long paitim Jisas long wip i gat nil. Long dispela taim stret PNG Pawa i pasim lait. Olgeta tok nogut i kamap...plis belhat bilong yupela long ol soldia, noken rausim long PNG Pawa.

Tokwin Tasol...



TV GAID

<p>5.30PM G FISHING NORTH AUSTRALIA: "Broome"</p> <p>6.00PM G NATIONAL EMTV NEWS</p> <p>6.30PM G TWENTY20: AUSTRALIA vs. NEW ZEALAND Venue: Sydney Cricket Ground.</p> <p>9.35PM M SUNDAY NIGHT MOVIE: UNDERBELLY: "The Tale of Two Cities"</p> <p>New Australian Drama Series about the true story of the 10 year gangland war that shocked Australia. Charming gangster Alphonse Gangitano, also known as The Black Prince, gets away with murder but finds himself in a deadly feud with the ruthless Moran Brothers. Small time crim Carl Williams take the first steps towards building his own empire as the police renew their efforts in trying to crack the powerful "Carlton Crew" gang. Stars Vince Colosimo, Rodger Corser, Caroline Craig and Frankie J. Holden.</p> <p>**SPECIAL 2-HOUR SERIES PREMIERE**</p> <p>11.35PM G HILLSONG</p> <p>00.05AM G NATIONAL EMTV NEWS REPLAY</p> <p>00.35AM Australia Network</p> <p>MANDE FEBRUERI 16, 2009</p>	<p>5.29AM STATION OPEN</p> <p>5.30AM G TODAY</p> <p>9.00AM CLASSROOM BROADCAST</p> <p>Education learning through television broadcast for Primary Schools for Grades 7 Mathematics & Science, Grade 8 Maths, Science; Grade 6 Personal Development.</p> <p>9.30am Grade 7 - Mathematics</p> <p>10.20am Grade 7 - Science</p> <p>11.10am Grade 8 - Mathematics</p> <p>12noon Grade 8 - Science</p> <p>1.00pm Grade 6 - Personal Development</p> <p>1.50pm Grade 7 - Making A Living</p> <p>2.30pm Teacher Training & DEPI Program</p> <p>2.59PM STATION OPEN</p> <p>KIDS KONA</p> <p>3.00PM G NEW MACDONALD'S FARM</p> <p>3.30PM G THE KINGDOM OF PARAMITHI</p> <p>4.00PM G SHARKY'S FRIENDS</p> <p>4.30PM G LAB RATS CHALLENGE</p> <p>4.57PM G EMTV TOK SAVE</p> <p>5.00PM G THE SHAK</p> <p>5.29PM G EMTV NEWS UPDATE</p> <p>5.30PM G HOT SOURCE</p> <p>5.55PM G CRIME STOPPERS</p> <p>6:00PM G NATIONAL EMTV NEWS</p>	<p>6.30PM G A CURRENT AFFAIR</p> <p>7.00PM G TOK PIKSA...Best of 2008</p> <p>7.30PM PG SUPER NANNY USA</p> <p>8.30PM PG SUDDEN IMPACT (final)</p> <p>Witness how car crash victims triumph over adversity. Narrated by Gary Sweet.</p> <p>9.00PM G DO IT GREEN</p> <p>9.30PM PG THE GIFT</p> <p>10.00PM M 20 TO 1: "Greatest TV Moments"</p> <p>11.00PM G EMTV NEWS REPLAY</p> <p>11.30PM Australia Network</p> <p>TUNDE FEBRUERI 17, 2009</p> <p>4.59AM STATION OPEN</p> <p>5.00AM G JOYCE MEYER Religious programme</p> <p>5.30AM G TODAY</p> <p>9.00AM EMTV PRIME TIME LINE UP</p> <p>Education learning through television broadcast for Primary Schools for Grades 7 Mathematics & Science, Grade 8 Maths, Science; Grade 6 Personal Development.</p> <p>9.30am Grade 7 - Mathematics</p> <p>10.20am Grade 7 - Science</p> <p>11.10am Grade 8 - Mathematics</p> <p>12noon Grade 8 - Science</p> <p>1.00pm Grade 6 - Personal Development</p> <p>1.50pm Grade 7 - Making A Living</p>	<p>2.30pm Teacher Training & DEPI Program</p> <p>4.57PM G EMTV TOK SAVE</p> <p>5.00PM G THE SHAK</p> <p>5.29PM G EMTV NEWS UPDATE</p> <p>5.30PM G HOT SOURCE</p> <p>6:00PM G NATIONAL EMTV NEWS</p> <p>30PM G A CURRENT AFFAIR</p> <p>6.57PM NEWS UPDATE IN TOK PISIN</p> <p>7.00PM G HAUS & HOME</p> <p>PNG's weekly guide to cooking, finance, child-care, health and gardening - presented by Irene Romel and new co-host Tania Mai.</p> <p>7.57PM EMTV TOK SAVE</p> <p>8.00PM PG EMERGENCY</p> <p>Go behind the scenes at a busy hospital emergency department</p> <p>8.30PM PG THE WAITING ROOM</p> <p>9.00PM M ARMY WIVES: "The Art of Separation"</p> <p>10.00PM M CANAL ROAD</p> <p>11.30PM Australia Network</p> <p>TRINDE FEBRUERI 18, 2009</p> <p>4.29AM STATION OPEN</p> <p>4.30AM G JOYCE MEYER Religious programme</p> <p>G TODAY</p> <p>6.00AM EMTV PRIME TIME LINE UP</p> <p>9.00AM CLASSROOM BROADCAST</p> <p>2.59PM STATION OPEN</p>	<p>KIDS KONA</p> <p>3.00PM G G2G: GOT TO GO (series premiere)</p> <p>3.30PM G THE KINGDOM OF PARAMITHI</p> <p>4.00PM G SHARKY'S FRIENDS</p> <p>4.30PM G LAB RATS CHALLENGE</p> <p>5.55PM G CRIME STOPPERS</p> <p>6:00PM G NATIONAL EMTV NEWS</p> <p>6.30PM G A CURRENT AFFAIR</p> <p>6.59PM G NEWS UPDATE IN TOK PISIN</p> <p>7.00PM PG 10 TO 1: "Triumphs & Tragedies"</p> <p>7.00PM PG THE WORLD AROUND US:</p> <p>8.00PM PG WEDNESDAY NIGHT MOVIE: A BEAUTIFUL MIND - (2001) Mystery/Drama - After a brilliant but social mathematician accepts secret work in cryptography, his life takes a turn to the nightmarish Stars: Russel Crowe, Ed Harris, Jennifer Connelly, Christopher Plummer. (Winner of Four Academy Awards)</p> <p>10.00PM G KINGAL MINISTRIES: "God is producer, presenter, provider"</p> <p>11.00PM G EMTV NEWS REPLAY</p> <p>11.29PM G JACK OF ALL TRADES</p> <p>11.30PM Australia Network</p>
--	---	---	--	--

SABA wari long ol Kataret Ailan

Raitim singsing we i stori long hevi bilong ol manmeri long hap...

OL TULUN, ol manmeri bilong ol Kataret Ailan (Cartaret Islands) long Atonomes Rijen bilong Bogenvil i gat hevi. Solwara i wok long karamapim ol liklik ailan bilong ol. Dispela i kamap long wanem long hevi bilong globol woming. Globol woming em senis we i wok long kamap long wol long ron bilong ren, win na san.

Oi manmeri long Papua Niugini (PNG) na ol-narapela kantri tu, nau i ken harim stori bilong dispela hevi bilong ol Kataret Ailan long wanpela singsing. Nem bilong dispela singsing em, olsem ol nem bilong ol ailan tasol – Cartaret Islands.

Biknem ben bilong Solomon Ailans (Solomon Islands), SABA, na Rolly Bogese husat i save wok wantaim na raun wantaim dispela ben, i bin raitim na mekim musik bilong dispela singsing.

Taim SABA na Bogese i bin pilai raun long PNG long 2006, 2007 na las yia, ol i save harim ol manmeri i stori long hevi bilong ol Kataret Ailan.

"SABA i wari long ol manmeri bilong ol Kataret Ailan, na i raitim dispela singsing long mekim ol manmeri luksave long hevi bilong ol na helpim ol," Bogese i tok.

Em i tok olsem bihain long ol i autim dispela singsing bilong ol, ol i laik i go long ol Kataret Ailan long mekim vidio klip long soim stret hevi we i wok long kamap long hap. Em i askim ol manmeri na bisnis long helpim na sapotim wok bilong mekim dispela vidio klip.

"Sori, save i stap wantaim yu..." em we singsing Cartaret Islands i save stat. Namba wan ves bilong singsing bai mekim skin gras bilong yu kirap, moa yet sapos yu save gut long we ol hai wara i wok long bagarapim laip bilong ol manmeri long ol dispela ailan.

Kores bilong singsing tu bai mekim yu wari na askim long wanem na God, husat em i god bilong marimari, i larim kain birua olsem i kamap long ol dispela ailan we ol manmeri i save stap amamas na'bel isi. Kores i olsem;

"Solwara katim laip bilong yu Sori ol pikinini mi kra i wantaim yu

Sori long pipel blong Carteret Islands

Yumi lavim olgeta, wantaim prea blong yumi

Yumi reskuim olgeta long Carteret Islands

Sori ol pipel blong Carteret Islands..."

Long dispela singsing SABA i traim long askim ol askim we ol manmeri bilong ol Kataret Ailan i wok long askim...bai ol i go we? Bai ol i mekim wanem? Wanem samting bai kamap long ol?

Dispela singsing em i gat musik we ol manmeri inap danis long en long ol naitklap. Tasol planti ol manmeri bilong Bogenvil bai luksave long dispela singsing olsem wanpela singsing we i tokaut long

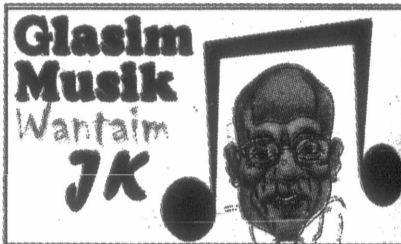

dispela hevi we i stap 10 i go long 15 yia nau. Hevi we ol gavman bilong Bogenvil na PNG i mas wokbung long stretim.

SABA i bin laik autim dispela singsing long Disemba las yia long namba 6 albam bilong SABA we ol i kolim Kandere Man. Tasol pikinini bilong Bogese, Young Davie, i bin laik autim albam bilong em long dispela taim tu. Olsem na nau SABA i bai autim dispela singsing Carteret Island em yet na long Mas o Epril bai ol i autim albam bilong ol.

Bogese i givim tok orait long mi long autim dispela singsing long PNG long kirapim awenes long hevi bilong ol Kataret Ailan. Bai yu ken harim dispela singsing nau long ol klab, hotel na redio stesin, na namba wan hap yu ken harim dispela wik em long ol redio stesin long kantri wantaim tu ol redio stesin long Bogenvil.

Tasol i gat ol ripot ol SABA tu bai kam long PNG long Epril long

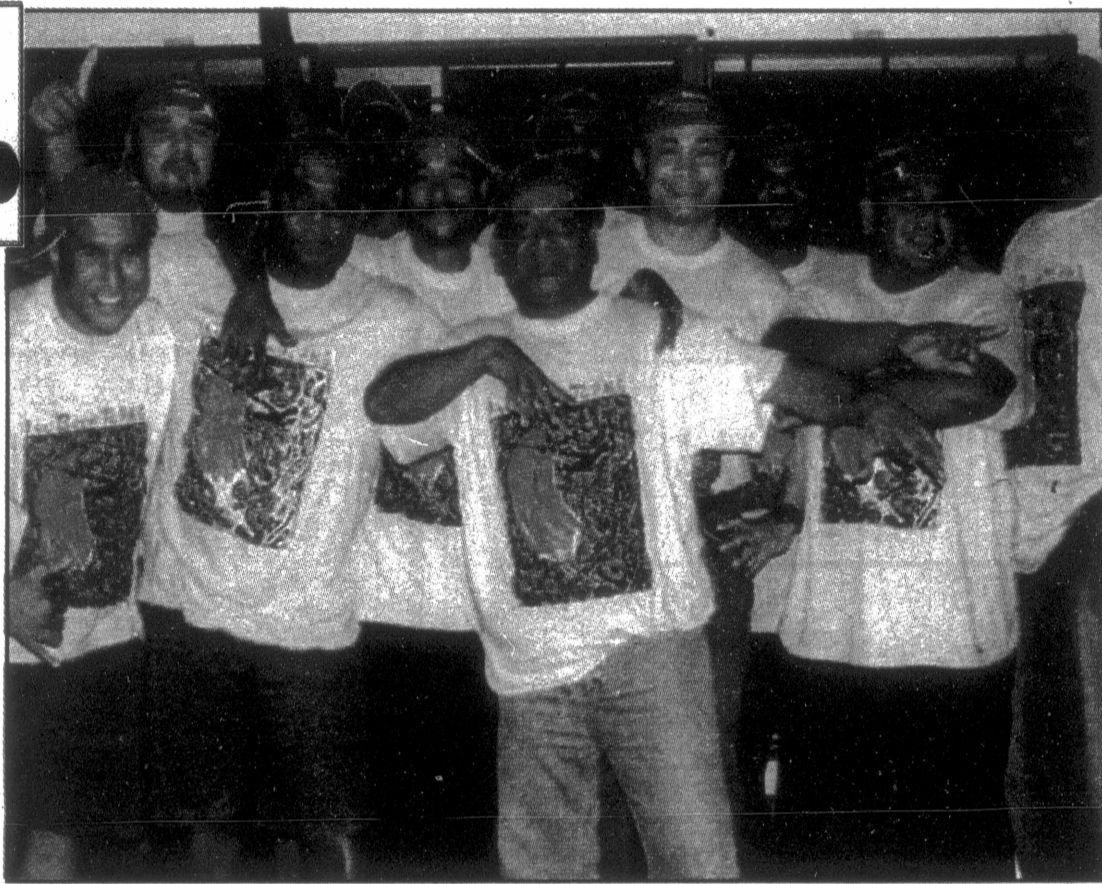

SABA: Man husat i go pas long raitim singsing long Kataret Ailan. Em sanap namel wantaim ben bilong em husat i mekim tua bilong em long promotim albam bilong em long 2007. *Poto: Nau FM*



Kataret Ailan i wok long go daun i stap long solwara. *Poto: Richard Lloyd Parry*

autim dispela singsing na albam bilong ol na long mekim vidio klip bilong ol long ol Kataret Ailan yet.

Nupela Presiden bilong Atonomes Rijen bilong Bogenvil, James Tanis, i mas sapotim dis-

pela wok bilong SABA long helpim ol manmeri bilong ol Kataret Ailan. Sapos Mista Tanis i laik toktok wantaim mi long dispela wok, em i ken ring long mi long telepon namba 323 4926 o emel gm.pvm.com.pg.

Ritim Glasim Musik olgeta Mande long *The National* niuspepa.

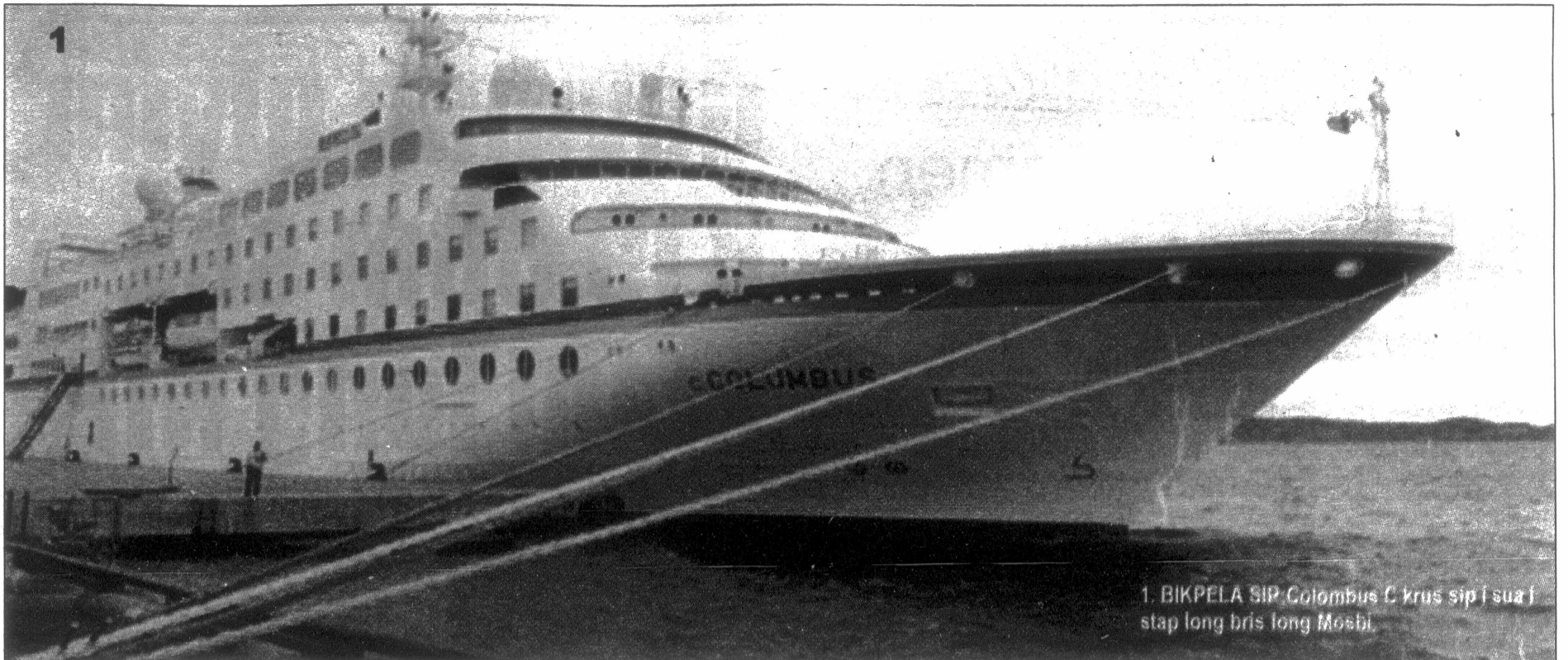

1. BIKPELA SIP Columbus C krus sip i sua i stap long bris long Mosbi.

Sip i kam, turis i kam

Veronica Hatutasi i raitim

PAPUA Niugini (PNG) i wok long lukim moa turis sip i kam long kantri. Ol provins olsem Madang, Milen Be, Bogenvil, Oro, na Is na Wes Nu Briten i wok long kisim planti ol turis. i go long ol long ol balus, tasol moa yet long ol sip.

Minista bilong Kalsa na Turisim, Charles Abel, long wanpela bung i bin tok ripot bilong namba bilong ol turis husat i kam long PNG i wok long go antap. Las yia, PNG i bin kisim 120,139 turis i kam long Australia, Amerika (United States of America), Siapan (Japan), Jemani (Germany), Inglan (England), Frans (France), Kanada (Canada), na Nu Silan (New Zealand). Las yia, ol turis i bringim K960 milion i kam long PNG. Dispela em K60 milion moa long yia 2007.

Las wiken, 500 turis bilong Jemani i kam long sip we i sua long wanpela bris long Fairfax basis long Mosbi. Ol turis i bin raun lukim ol ples long Mosbi, tasol 90 turis i bin kisim balus i go long raun lukim Maun Hagen long Westen Hailans provins.

Foapela grup turis i save kam long PNG. Em long mekim wok bisnis (45 pesen), edukesen (1 pesen), holide o malolo (34 pesen) na wok (18 pesen).

Orait, dispela ol turis bilong Jemani i stap nau long PNG em ol i bin kam long holide sip bilong Hapag Lloyd ol i kolim long Columbus C. Melanisen Turis Sevis (MTS) i bin stretim dispela wokabaut.

Bosman bilong MTS, Se Peter Barter, i tok ol turis i amamas long ol ples, manmeri na ol samt-ing ol i lukim long long raun bilong ol long Mosbi na Hagen.

Se Peter i tok grup husat i bin go long Hagen i bin amamas long sevis bilong Air Niugini, kaikai na lukluk raun i go long ol ples we ol i bin lukim ol pasin tumbuna olsem ol singsing.

Colombus C bai raun i kam gen long PNG long mun Oktoba. Na long dispela taim, em bai raun i go long Madang.



2. **WELKAM:** Ol ples lain bilong Madang i tok welkam long ol turis long Madang Risot Pak eria taim ol i bin kam long sip, Seven Sea Voyager 2, long Madang las yia.

3. **SPIN LONG MOSBI:** Ol manmeri husat i gat wok long helpim soim ol turis raun, i soim ol turis long ol bas ol i mas kalap na raun lukim ples long en.

4. **MADANG I SWIT:** Sip Seven Sea Voyager 2 i bin raun i go long Madang las yia.



THEODIST LTD

YOUR LEADING STATIONERY SUPERSTORE!

"Back to School, Back to Theodist!"
"For All Your School Supplies!"

Visit our showroom before you step into the classroom!!

Waigani Drive, Port Moresby
 Down Town, Port Moresby
 Milfordhaven Road, Lae City

Ph: 325 6500
 Ph: 321 5667
 Ph: 472 5488

Fax: 325 0302
 Fax: 321 5998
 Fax: 472 7838

Email: sales@theodist.com.pg
 Email: townsales@theodist.com.pg
 Email: cbaker@global.net.pg

THEODIST LTD



Noken pait long graun we nogat divelopmen i kamap long en

James Kila i raitim

WANPELA bikpela kopi bisnisan long Isten Hailans provins, Fero Yasona, i tok olsem ol manmeri i mas noken pait nating nating long graun we nogat divelopmen i kamap long en.

Mista Yasona i mekim dispela toktok las wik Fraide taim em i go stap insait long wanpela belisi bung namel long ol wanpisin bilong Pundipasa na Bioka long Gadsup eria long Obura-Wonenara distrik long Isten Hailans provins.

"Wanem as tru na yupela pait pait long graun?"

"Mi no lukim kopi i gro antap long dispela graun yupela i pait long en," Mista Yasona i tok.

Em i tokim ol dispela tupela wanpisin long stop pait na wok strong long planim kopi long wanem ol lain long ovasis i save laikim kopi bilong

Papua Niugini (PNG).

Mista Yasona i tok olsem em i save raun long ovasis na planti lain i save laikim kopi bilong PNG, tasol ol manmeri i no bringim i go bikpela prodaksen bilong kopi long kantri.

Em i tok olsem ol lain ovasis husat i laik baim kopi em i bungim ol i tok olsem sapos PNG i salim 5-milion kopi beg ol dispela lain bai baim yet.

"Kopi prodaksen bilong yumi em i daunbilo yet, olsem na yupela i mas stop pait na planim moa kopi na salim long mi.

"Mi poro bilong yupela Fero mi stap na mi redj long baim kopi bilong yupela," Mista Yasona i tok.

Mista Yasona, husat em papa bilong Ramu Kopi long Kainantu em wanpela bikpela kopi bisnisan long Hailans na Momase rijen. Kampani bilong em i save helpim gut ol smolholda kopi fama long hap bilong Madang na tu

long Morobe provins na karim kopi bilong ol i go long faktori bilong em.

Em i tok tu olsem planti ol graun long Hailans i stap nating na ol manmeri i mas noken raun nating na kros namel long ol yet na pait.

Em i tok ol i mas putim han long graun na wok na planim kopi na kopi bai helpim sindaun bilong ol na pikinini na tumbuna bilong ol long taim bihain.

Mista Yasona i tok olsem gavman na ol lain olsem Kopi Industri Koporesen (CIC) i gat moa wok long mekim long bringim kamap prodaksen bilong PNG kopi long wanem namba bilong kopi prodaksen bilong kantri i stap daunbilo yet.

Em i tok olsem em i moa long 10-pela yia nau we CIC i tokaut long bringim namba bilong kopi bilong PNG i go antap long 2 milion beg tasol CIC i no mekim wanpela samting.

Gavman givim K19.88m sek mani long NIP

Paul Zuvani i raitim

ANINIT long Lihir Memorandum bilong Agrimen (MoA) gavman i mas bihainim ol tok i stap long lukim wanem samting em i tok long mekim i mas kamap.

Nau long dispela taim gavman i gat dinau olsem K90.2 milion long Nu Ailan Provinsel Gavman (NIPG) long royalti bilong Lihir Gol Main.

Dinau mani i kamap long dispela mak long wanem tupela gavman wantaim i no bihainim ol tok i stap long dispela MoA.

Long lukim kain pasin i no kamap nesenel gavman, NIPG na divelopa i mas sindaun na glasim gen dispela Lihir tok orait (MoA), Praim Minista Gren Sif Se Michael Somare i mekim dispela tok long taim em i givim K19.88m hap mani bilong dispela K90.2 milion long Kavieng long Mande dispela wik.

"Long helpim na stretim dispela dinau, mi givim K19.88 milion long Nu Ailan Provinsel Gavman long tude (Mande, Febuari 9).

"Narapela K20 milion long Buluminski Haiwe em gavman i givim pinis insait long 2008 Saplementari Mani Plen bilong em."

"Nu Ailan Provinsel Gavman i ken yusim sampela bilong dispela mani long wok bilong em.

"Dispela em namba wan hap bilong pe em gavman i givim na bai skruim gen long ol taim i kam."

Em i tok wantaim pemen we i kamap gavman i gat K20.2 milion long em i mas baim yet na olsem em i givim tok long ol

opisa bilong em long painim hap we ol i ken kisim mani na givim.

Em i tok em i pas yet long dispela MoA olsem na em bai mekim narapela K30.12 milion long bihain taim.

Bihainim pemen bilong K19.88 milion gavman i gat K70 milion we i mas baim yet.

Pastaim long kain bung na pemen i kamap Se Michael i rait long Se Julius Chan, Gavana bilong Nu Ailan na i tok, "Em i laik bilong tupela gavman wantaim, nesenel na provinsel, long lukim Lihir tok orait i karim kaikai."

Long ol hevi i stap bihain long kamap bilong dispela MoA we i lukim gavman i no mekim ol pemen Se Michael i tok olsem dispela em long wanem sampela wok we i stap ausait long MoA i kam insait nating long lukaut bilong MoA.

"Mi laikim bai i mas i gat oda o sistem i stap long lukim olsem mani bilong Lihir MoA i mas go het na i go aut long rot em i mas go aut long em.

"Na sapos ol i mas go aut, nogat wanpela samting i mas pasim ol.

"Mi no laik lukim o harim gen long hevi mipela i bungim nau," Se Michael i tok.

Em i tok em i givim pinis oda long ol opisa bilong em long redim na stretim ol samting bai olgeta grup i pas long wok bilong Lihir Gol Main i bung gen na stretim ol tok.

"Taim kain samting i kamap, ol tok i kamap na i stap insait long dispela MoA i kamap tru na i karim kaikai," Se Michael i tok.

Ok Tedi kampani stretim Kiunga ples balus

ASUA bilong gavman i no stretim ol ples balus long kantri i lukim ol planti i bagarap na i ol balus i no inap long ron moa.

Dispela i lukim tu wok-abaut bilong ol manmeri husat i save yusim tasol balus na kisim sevis long em i hat.

Wanpela bilong dispela ol ples balus em Kiunga long Westen provins.

Tasol ol opisa na ol manmeri long Kiunga i no inap wari long wanem bikpela

Ok Tedi Main long hap bilong ol i kam long helpim bilong ol.

Long las wik Ok Tedi i salim ol masin na ol opisa bilong i go na stretim ol hap we i bagarap.

Ol wok em Ok Tedi i mekim i kisim ol hap olsem kolta we balus i ron long em, stretim graun i bruk, katim gras na brumim ples balus.

Ol opisa i makim kos bilong dispela wok olsem K50,000 na kampani i luk-

luk long gavman i bekim olgeta dispela mani bilong em we em i yusim.

Kiunga bihain long Tabubil pies balus i namba tu long provins long i save kisim moa manmeri na kago.

Bipo long kain wok i kamap na long las tupela wik we Kiunga ples balus i pas long em ol pasindia we i mas yusim dispela ples balus i no inap long yusim.

Ol i yusim Ok Tedi Tabubil pies balus we ol i bihainim Tabubil-Kiunga rot long go aut o long go long Kiunga.

Planti bilong dispela ol pasindia em ol wokmanmeri bilong pablik sevis na ol skul pikinini i kisim taim long malolo long Krismas.

Air Niugini, Airlines PNG na MAF i save yusim Kiunga ples balus.

OK Tedi Maining mausman bilong enjiniaring na pawa sevises, John Iru i tok kampani i tanim ol risos bilong en long mekim ol arapela wok na i givim dispela taim long stretim Kiunga ples balus.

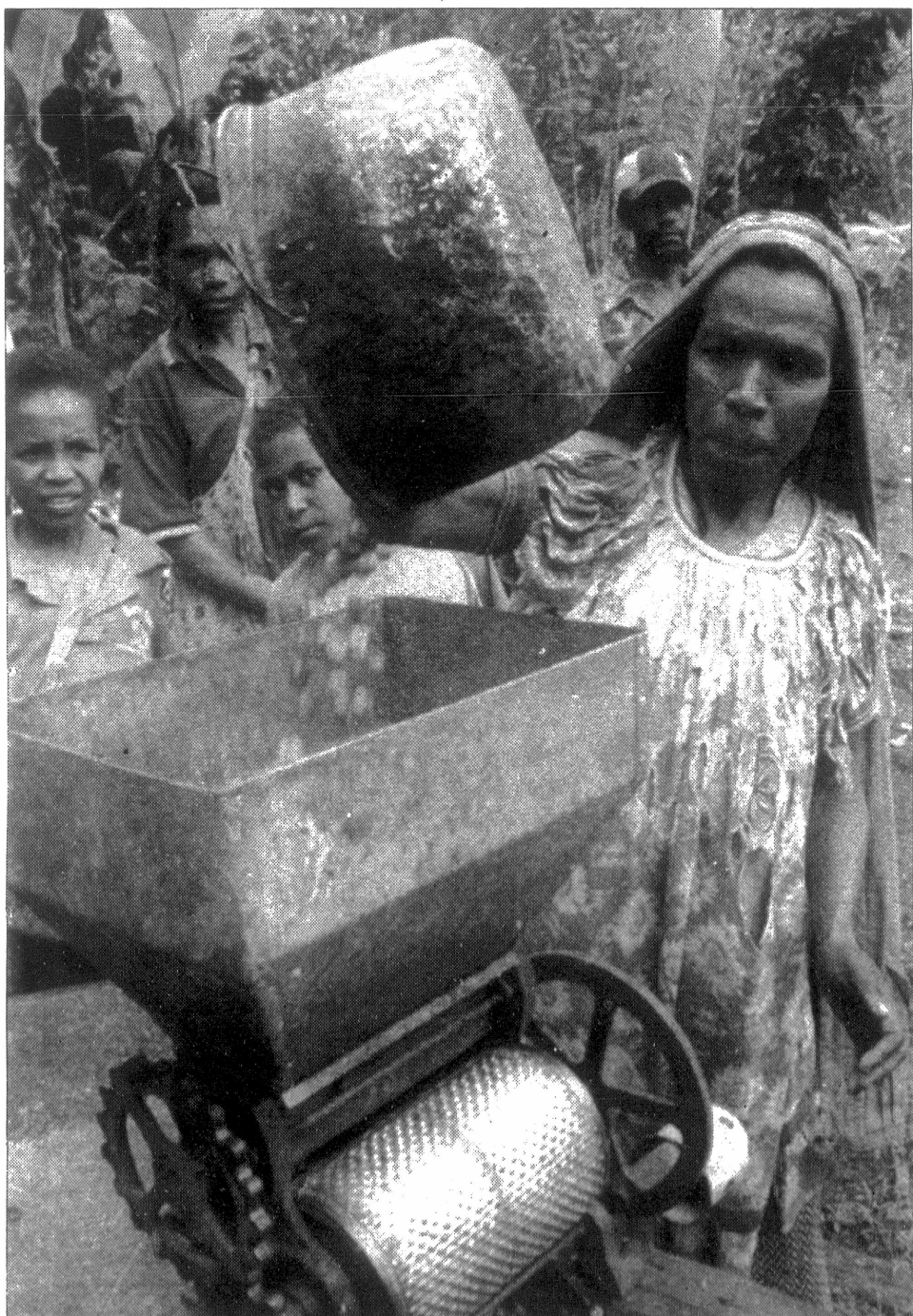

KOPI TAIM: Kopi em bikpela wok bisnis long PNG. Tasol em i ken bikpela moa. Wantok Niuspepa Poto



STRETIM: Ol wokman bilong OTML i wok long stretim ples balus long Kiunga.

Ol welpam prut i sting long Cargil welpam

Egareka Greg Noine i raitim

MOA long K2 milion wel pam prut i sting na bagarap long taim ol trak bilong kisim ol kaikai bilong welpam long wanwan smol holda blok long Cargil Wel Pam Mil arere tasol long Popondetta, i no kam long taim.

Mil i stap long Siroga inap long 2 kilomita mak. Tasol ol trak i kam bihain long taim long wanem Cargil Wel Pam kampani i opim na kirapim wok long nupela mil bilong en long Sumbiripa i stap 5 kilomita antap long Popondetta/Kokoda Haiwe.

Sumbiripa Mil i nogat ol trak bilong kisim ol kaikai bilong wel pam long ol smol holda blok, na olpela Siroga Mil i mas tilim ol trak namel long tupela mil wan-

taim na daunim hamba bilong ol trak long wanwan divisin. Dispela i kamapim dispela hevi.

Tu fi balens i go antap tru na tupela trak tasol i ron long kisim ol wel pam long ol smol holda blok i no inap. Dispela em long wanem sisen bilong wel pam mau i kam bek gen na prodaksen levul i antap tru.

Planti smol holda blok i katim na putim 8-pela, 9-pela na 10-pela umben o net wel pam.

Son 1 inap long nambis bilong Popondetta na i go insait long bikples inap 800-1000 hekta graun eria, na tupela trak i no inap long surikim olgeta wel pam i go long mil.

Wanpela wel pam growa long Son 1, Sorovi Divisin, Gispou Zarei, i tok olgeta wel pam i sting na bagarap.

Em i tok smol holda

dipatmen bilong Cargil i mas hariap na painim sampela rot long surikim ol welpam i go long mil.

Mista Zarei i tok olsem fam get fi i stap long K91.36 long wanwan tan (tone) na taim wel pam i sting na bagarap hevi bilong wel pam i go daun tru.

Em i tok sampela groa i katim na putim tupela na tripela umben na i no inap kisim gutpela mani long wanem ol i no inap bungim wan tan (tone) long kisim K91.36 tasol, bai ol kisim K30-K40 na ol bai lukautim famili bilong ol olsem wanem?

Mista Zarei i tok tu olsem, em i taim nau bilong ol pikinini i go long skul, na wel pam i gat hevi yet. Tasol em i gutpela long kisim gut tan (tone) na lukluk long ol skul fi bilong ol

Ol Oro wel pam groa kros long OPIC

Egareka Greg Noine i raitim

HEVI bilong wok bisnis long wol i go daun tru i daunim wok bisnis bilong wel pam long Oro provins na planti welpam groa i no amamas long menesmen bilong Welpam Industri Koporesen (OPIC) long i no lukluk long apim prais bilong wel pam i go antap liklik.

Wel pam i kamap bikpela kes krop bilong Oro na bringim mani i kam wantaim samting olsem 7,800 wel pam groa long nambis bilong provins na i go antap long maunten long Kokoda sab distrik.

Tasol hevi bilong prais i go daun na rot na bris bagarap i givim hat traim tru long ol groa long katim na salim welpam i go long faktori. Sampela groa i wok long katim na karim welpam bilong ol inap long 4-pela na 5-pela kilomita long bikrot na salim, tasol hatwok ol mekim long karim i nogat bikpela mani long wanem prais bilong wel pam nau i stap long K91.64 long wanwan tan.

Wanpela groa long Sorovi Senses Divisin, John Denhurst i tok, "Ol opisa bilong OPIC i laikim mipela long planim wel pam, tasol i

nogat gutpela tok klia long lukautim na katim.

"Ol i raun tasol long motobaik bihainim bikrot tasol. I nogat inspeksen na prodaksen ripot bilong wanwan blok ol save soim mipela.

"Hevi bilong rot na bris i stap yet, nau i gat hevi bilong prais tu i go daun olgeta, na bai mipela mekim wanem?"

Mista Denhurst i askim ol memba bilong palamen long Oro long lukluk long dispela hevi na rausim OPIC na bringim Dipatmen bilong Praimeri Industri (DPI) i kam bek long ronim wok wel pam.

Em i tok DPI i bin wok gut inap OPIC i kamap na wok i bagarap.

Ol popondetta wel pam groa i save givim K5 olgeta potnait i go long OPIC olsem levi fi na bungim olgeta mani wantaim, em inap long K39,000 long wanpela potnait.

Mista Denhurst i laik save wanem rot OPIC i save yusim dispela mani? Bipo Prinsipel bilong Popondetta Agrikalsa Kolis na nau wanpela groa, Allan Daure, i tok Wol Benk i save givim moa long K3 milion long Papua Niugini long ol manmeri i planim wel pam, tasol em i no klia long wanem as na olgeta rot na bris i bin bagarap inap wanpela yia na tupela mun, na nau prais

bilong wel pam i go daun tru.

Mista Daure i tokaut klia olsem dispela K3 milion em Wol Benk i givim bilong helpim ol wel pam groa long bringim wara saplai, pawa, apim prais i go antap na stretim rot na bris.

Em i tok olsem OPIC i mas i gat gutpela mani plen na yusim gut olgeta mani long helpim ol groa, na maski long baim ol trak na motobaik tumas.

Long las wik, ol wokman bilong Wol Benk i raun wantaim ol welpam groa na askim wanem kain wok OPIC i mekim long K3 milion Wol Benk i save givim olgeta yia. Planti groa i bekim tok bilong ol opisa olsem ol i stap long strong bilong ol yet na i no save olsem Wol Benk i save helpim ol. Dispela K3 milion Wol Benk i save givim i go long ol ples olsem Biiala, Hoskins, Poliamba, Popondetta na Milen Be.

Mista Daure i tok sori olsem bekim i kam long ol groa i no gutpela tumas na i luk olsem Wol Benk bai stopim mani em i save givim long helpim ol groa.

Wantok Niuspepa i traim long kisim operesen menesa bilong OPIC long kisim tingting bilong em long dispela ol toktok tasol hevi bilong telepon i no wok na dispela i no kamap.

STRONGPELA BANANA



GUTPELA: Rosa Kambuou (raithan), wanpela savemeri husat i wok wantaim Nesanel Agrikalsa Rises Institut (NARI), i promotim kain diwai banana olsem long Pasifik we sik bilong banana ol i no inap kisim. Foto: Senior Anzu

Pasifik bai baim ol kaikai bilong em yet long ol yia i kam, saveman i tok

Josephine Yaga i raitim

SEKYURITI bilong kaikai (food security) o kaikai i no inap sot na bai i gutpela kaikai i ken kamap gutpela moa sapos ol Pasifik Ailan Kantri na Teritori (PICTs) i apim prodaksen bilong ol kaikai ol i groim long ol kantri na Pasifik yet, na kaikai ol dispela kaikai.

Dispela em toktok bilong Dairekta bilong Len (graun) Risos Divisin long Sekretariat bilong Pasifik Komyuniti long Fiji, Aleki Sisifa.

Mista Sisifa i tok pasin bilong ol kantri na teritori long Pasifik long baim ol kaikai i kam long ol ovasis kantri i no long Pasifik bai i no

kamap tumas long ol yia i kam long wanem kos bilong ol kaikai na piul i bai i go antap.

Em i tok ol wok glasim i soim olsem ol kaikai we ol i baim i kam long ovasis i save kos bikpela mani tasol tu sampela liklik Pasifik ailan kantri i no longtaim i go pinis i wok long i gat hevi long ol sik we i kam long pasin bilong kaikai planti bilong ol dispela kaikai tumas.

Mista Sisifa i mekim ol dispela toktok long namba 3 kibung bilong ol Het bilong Agrikalsa na Forestri (HOAFS) long Pasifik we i bin kamap i no longtaim i go pinis long Apia, Samoa.

Papua Niugini (PNG) i bin stap long dispela kibung tu. Ol hetman bilong Dipatmen bilong Agrikalsa na Laipstok, Nesanel Agrikalsa Kwaratin na Inspeksen Atoriti, Forestri Dipatmen na Nesanel Agrikalsa Rises Institut (NARI).

Bikpela wok dispela kibung i toktok long en em ol isyu we i wok long kamap long rijen olsem na wol olsem klaimet senis na developmen bilong ol kastomari graun. Olgeta tupela yia ol memba bilong HOAF i save bung long toktok long ol kain isyu olsem we i lukluk long agrikalsa prodaksen na we ol i wok long yusim ol fores.

Dispela kibung we i bin kamap long Samoa, em ol Ministri bilong Agrikalsa na Forestri bilong Gavman bilong Samoa i go pas long en. Long dispela kibung ol i kamapim Statejik Plen bilong 2009 i go inap long 2012.

NARI Prinsipel Saintis, Rosa Kambuou husat i bin stap long dispela kibung tu long makim NARI, i tok olsem dispela stratejik plen i lukluk moa yet long strongim sekyuriti bilong kaikai long ol kantri wantaim tu wok bilong bosim gut wok agrikalsa na forestri.

Tok pilai wantaim Kanage olgeta wik

PEN PREN

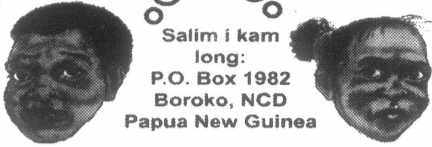

Salim i kam long:
P.O. Box 1982
Boroko, NCD
Papua New Guinea

NEM: James Babe
KRISMAS: 16 (man)
ADRES: Tarangu Primary School, P.O. Box 877, Mt Hagen, WHP
SAVE LAIKIM: Pilai tas, tok pilai, go lotu, harim musik, na ritim buk.

NEM: Patua Pilag
KRISMAS: 17 (meri)
ADRES: Bemal Primary School, P.O. Box 2103, Madang, Madang Province
SAVE LAIKIM: Go lotu; tok pilai, stori na swim.

NEM: Wali Maima
KRISMAS: 23 (man)
ADRES: BCF Vocational Technical School, P.O. Box 1241, Mt Hagen, WHP
SAVE LAIKIM: Pilai ragbi tas, harim musik, go lotu, mekim pren na tok pilai.

NEM: Nianda Maluku
KRISMAS: 29 (meri)
ADRES: Paul Paraka Lawyers, P.O. Box 2140, Madang, Madang province
SAVE LAIKIM: Mekim pren, tok pilai, harim musik, na mekim haus wok.

NEM: Thomas Kamp
KRISMAS: 30 (man)
ADRES: C/- Hargy Oil Palm, P.O. Box 21, Biella, WNB
SAVE LAIKIM: Harim musik, ritim buk, raitim pas, na mekim pren.

NEM: Cynthia Quashie
KRISMAS: 28 (meri)
ADRES: P.O. Box 671, New Site Agona, Ghana, West Africa
SAVE LAIKIM: Raitim pas, mekim pren, na raun raun.

NEM: Rose Dadzie
KRISMAS: 27 (meri)
ADRES: P.O. Box 671, New Site Agona, Ghana, West Africa
SAVE LAIKIM: Danis, tok pilai, raun raun na raitim pas.

NEM: Elizabeth Bartels
KRISMAS: 26 (meri)
ADRES: P.O. Box 191, Russell Lane, Oguua, Ghana, West Africa
SAVE LAIKIM: Pilai spots, raun raun, harim musik, na raitim pas.

NEM: Georgina Boham
KRISMAS: 26 (man)
ADRES: P.O. Box 191, Russell Lane, Oguua, Ghana, West Africa
SAVE LAIKIM: Raun raun, harim musik, pilai basketbol, na salim presen.

NEM: Wolyng Boaz
KRISMAS: 19 (man)
ADRES: P.O. Box 180, Brandi Secondary School, P.O. Box 108, Wewak, ESP
SAVE LAIKIM: Harim musik, pilai gita, pilai kibod na raitim pas.

TOK PILAI

WANTAIM
Braks Kanage



Lotu man
Kanage go long lotu long Biella. Em sindaun long baksait na lukim olsem ol man wok long go antap long fran na toktok long we ol i bungim Jisas na we em i senisim laip bilong ol.

Kanage harim ol toktok go na em tu go long fran. Em tu laik tokaut long stori bilong em. Em tok olsem, "Halo olgeta gutpela man-meri. Nem bilong mi Kanage, meri bilong mi Sawombo, fes bon em Nakuvu, seken em Kauanombo, haus bilong mi stap arere long rot kolta na tenkyu na God bles!"

Maifo Mahn Biella

Mangi Madang
Kanage em bilong Karkar na em raun go long Lae. Taim em stap long Lae, em prenim wanpela meri Samarai. Meri ya skelim pasin bilong Kanage na em i gat bikpela laik tru long maritim em. Wanpela taim tupela sindaun stori long Voco Poin na meri ya tokim Kanage long

Taim bilong kaikai stret, sampela lain i kam lukim Kanage na famili bilong em. Nau meri bilong em i stat long skelim kaikai bilong ol.

Kanage hangre tru na em painim hat long tokim meri bilong em long putim planti rais long plet bilong em.

Em nau Kanage singsing olsem, "Maunten...maunten...nogut bai yu kisim taim." Meri bilong em harim na em skelim planti rais long plet bilong em na em tu singsing, "Mi save...nogut mi kisim taim tru."

Tok Inglis, "Kanage, I love you!" Kanage harim Tok Inglis ya na em tokim meri Samarai, "Mi mekim wanem pani samting na yu lap long mi?" Meri Samarai krai long toktok bilong Kanage. Kanage lukim em karai na em tokim em, "Kanage i no dai na yu krai long mi. Sapos Kanage lusim yu, bai yu krai moa ya!" Krai bilong meri Samarai pinis na em bihainim Kanage go long Madang.

STK Krx Madang



Las toksave ! Wina bilong dispela wik Kanage em:
Maifo Mahn - Buvussi
Plis ring i kam long fon 325 2500 na askim long Allan Tolire long kisim prais bilong yul

Satan Kanage

Kanage em bilong Kubalia.

Em save stap long wanrot long Yawasoro. Long ol kain pasin bilong em long bikhet, tok nogut planti, kisim wara na sutim kandis tumas, ol komyuniti givim nem bilong em Satan. Wanpela Sande, Kanage wantaim ol Yamari sutim kandis stap. Ol man-meri pinis lotu na

wokabaut kam. Wanpela bikman bilong ol lukim ol manmeri pilai kas na em tokim ol, "Nau Sande ya.

Nogat wanpela bilong yupela go lotu. Em Satan tasol dispela nogut spirit save grisim yupela na paulim tingting bilong yupela. Olgeta taim yupela save pilai kas na mekim ol pasin nogut!" Em i laik tok-tok yet tasol Satan

(Kanage) kirap putim wanpela han long em. Bikman ya pundaun krangi. Kanage tokim em, "I no mi grisim ol.

Em ol bikpela man-meri, ol i gat tingting, em mani bilong ol!" Tarangu man ya min olsem Satan, Lusifa, i no Satan Kanage.

RK Wewak

Salim gutpela Tok Pilai i kam na winim wanpela Kanage T-siot!
Salim i kam long P.O. Box 1982, Boroko, NCD.
Salim tu i kam long Email:atolire@wantok.com.pg

Painim Tok!

Raitim daun wanem pani samting yu ting i gutpela insait long babol long potu...



Susa, yu lukim tu? Mi kisim yu long kamera bilong mi. Yu luk smat stret yah!

Soim mi! Kam mi lukim! Tru ya! Yu hap meri long kisim potu ya!

Wina bilong dispela wik em:

Anne Karayo -
St Luke Primary School, P.O. Box 3422,
Lae, Morobe Province.
Ringim telepon namba 3252500 na askim Allan Tolire long prais bilong yul

Painim Tok!

Raitim daun wanem pani samting yu ting i gutpela insait long babol long potu...



Yumi wet, wet na klostu tudak nau. Nogat wanpela PMV kam ya!

Em tru ya! Sapos nogat olgeta bai yumi slip long we? Mi wari ya!

DAI YU WINIM WANPELA WANTOK T-SIOT O LAPLAP!

Salim i kam long: Paini Toktok Kompetisen, P.O. Box 1982, Boroko, NCD Port Moresby - Papua mipela i lukim wanem samting yu raitim i gutpela bai yu winim wanpela Wantok T-Siot o laplap na bai mipela i putim i go insait long pepa.
Wina bilong Painim Tok pilai em:
William Numbrea - P.O. Box 978, Wewak
Ringim Fon: 325 2500 na askim long Allan Tolire long prais bilong yul

Profeseneel spot -mani gem

Andrew Molen i raitim

TAIM yu liklik na i save pilai tumas na i no tingting long mekim wok long haus o long skul, papamama i krosim yu na paitim yu.

Oi bai tokim yu tu olsem pilai bai no inap givim yu mani o kaikai, tasol ating dispela i wok long senis nau.

Dispela senis i ken kamap long wanem planti ol spot nau i wok long kamap profeseneel.

Profeseneel em olsem, ol pilaia, kosa na arapela wokmanmeri long dispela spot bai kisim pe long wok bilong ol olsem ol arapela wok.

Pe bilong sampela tu i moa long ol arapela wok mani.

Oi neseneel resis long Papua Niugini (PNG) olsem SP Kap bilong ragbi lig, Neseneel Soka Lig bilong soka, Supa Siris bilong kriket, boksing na kikkoksing em sampela oi spot we i kamap profeseneel pinis.

Profeseneel spot long PNG i nupela yet na ol spotmanmeri i no save kisim mani na sainim ol bikpela kontrak olsem ol arapela kantri yet tasol bihainim taim bai PNG i ken kamap long dispela level.

Insait long oi profeseneel spot, ol pilaia, kosa na ol arapela opisel tu i gutpela moa long wok bilong ol na i no save mekim samting nating.

Long dispela as ol profeseneel spot i no save resis wantaim ol amata spot.

Sampela ol bikpela resis olsem Olimpik Gems, Komonwelt Gems na Saut Pasifik Gems i no save givim tok orait long ol profeseneel spotsmanmeri i pilai long insait long ol gem bilong ol.

Oi pilaia i save kamap olsem ol profeseneel manmeri we pasin na tingting bilong ol i save senis tu.

Olgeta wok, raun na pilai bilong ol insait long fil taim ol i pilai na ausait i no save kamap nating, ol i save harim tok na wok hat bihainim ol lo bilong klap na spots bilong ol.

Planti ol arapela spot long PNG olsem volibol, softball, ragbi union, basketbol na ol arapela i stap yet long amata level.

Amata em olsem dispela ol resis i stap long wanwan provins na ol i save bung tasol long ol neseneel semp-

onsip – i nogat neseneel resis bilong ol olsem SP Kap na NSL.

Oi lain i pilai insait long ol amata resis i no save kisim pe.

“Mi ting em i gutpela long mekim moa spot i kamap profeseneel long wanem yumi mas givim moa luksave long ol spotsmanmeri bilong yumi,” profeseneel kikkoksa na promot, Stanley Nandex i tok.

Planti bilong ol i kam long ol strit na ples na i nogat gutpela save long painim wok olsem na profeseneel spot i ken helpim ol long kisim mani long gem bilong ol, em i tok.

“Taim ol pinis pilai, ol i mas gat sampela mani long stretim sindaun bilong ol na profeseneel spot i ken helpim ol,” Nandex i tok.

Planti ol arapela profeseneel spotsmanmeri tu i ken tokaut long ol gutpela samting i kamap long laip bilong ol.

Stanley Gene na Marcus Bai i pilai profeseneel ragbi lig long Australia na Ingran (England) na nau ol i save toktok strong long ol yangpela manmeri mas wokhat bai ol i ken kisim luksave na go pilai long dispela kain resis tu.

Oi arapela bikpela kantri olsem Australia, olgeta bikpela spots bilong ol i gat neseneel resis na olgeta i kamap profeseneel.

Oi spot olsem kriket, soka, ragbi lig, ragbi union, volibol, basketbol, besbol, boksing, kikkoksing, tenis na netbol tu.

Dispela em ol bikpela kantri wantaim planti mani na bisnis long ples bilong ol we i mekim isi long kain samting olsem.

PNG nau i stap long hap rot pinis we i lukim ol profeseneel resis bilong PNG em i semi profeseneel yet.

Semi profeseneel em olsem ol save kisim pe long gem bilong ol tasol ol i no stap trening na pilai ful taim stret.

Planti pilaia i gat wok mani na arapela samting bilong ol tasol i save kamap long trening na pilai long neseneel level.

Profeseneel tru i min ol bai lusim olgeta samting na pas tasol long gem bilong ol i go i nap ol i lusim gem.

Taim olgeta samting i kamap gut bihain taim bai PNG tu i ken mekim olgeta

spot bilong en i kamap ful profeseneel stret.

Tasol bikpela mani save go insait long ronim ol profeseneel spot olsem na i mas i gat gutpela sapat bilong ol bikpela bisnis insait long komyniti.

Profeseneel spot i ken kisim ol arapela gutpela samting tu i kam long ol manmeri tu na i no long ol pilaia na klap bilong ol tasol.

Oi profeseneel spot klab i save wokbung gut wantaim ol komyniti bilong ol, moa bisnis bai kam long ol ovasis kantri na tu ol ples bilong pilai bai kamap gutpela moa long holim ol dispela gem.

Sampela i ting profeseneel spot em i no gutpela long wanem olgeta spotsmanmeri bai tingting long kisim mani na bai nogat pilaia moa long makim kantri long amata level.

Tasol bipo PNG profeseneel boksa Martin Benny i tok dispela em i no tru.

Amata bai stap yet long wanem, makim kantri em i bikpela samting,” Benny i tok.

PAIT: Profeseneel boksing i kam bek long PNG las yia.

PILAI: SP Supa Siris kriket em profeseneel gem tu.
Oi Wantok Niuspepa Poto



BIKPELA GEM: SP Kap em profeseneel ragbi gem bilong PNG.



SEVIM GOL: Goli bilong Sepik FC, Warisan Ronald i paitim bal i go ausait long gol maus bilong em long gem bilong ol agensim CMSS Tiger Rapatona long Mosbi las wik Sarere. Rapatona i win 1-0. **OL POTO: ANDREW MOLEN**

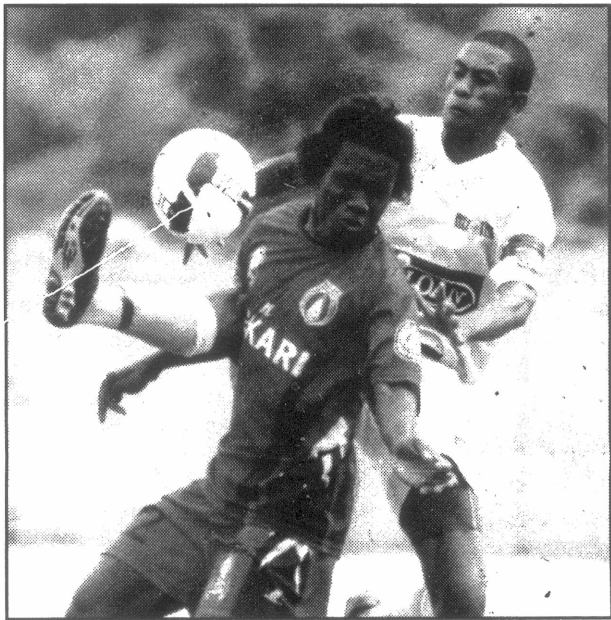

KLOSTU: Marampau Andrew bilong Esiloan Uni Inter FC klostu tru i rausim yau bilong Benjamin Mela bilong Hekari Souths United FC long gem bilong ol long Mosbi. Tupela tim i dro 1-1.

OOPS: (Poto daunbilo) Dick Bart Junia bilong United Brothers i rausim het bilong em bipo long bal i kam long Mosbi sof-bol gem bilong ol agensim Brown Eagles las wik Sande. Tupela tim i dro 6-6.



KALAP: Gol difenda bilong FinCorp i traim long pasim BSP gol atek (GA), Renagi Dringo long prima divisin bilong netbol resis bilong ol praiwet kampani long Mosbi las wik Sande. BSP win 30-8.

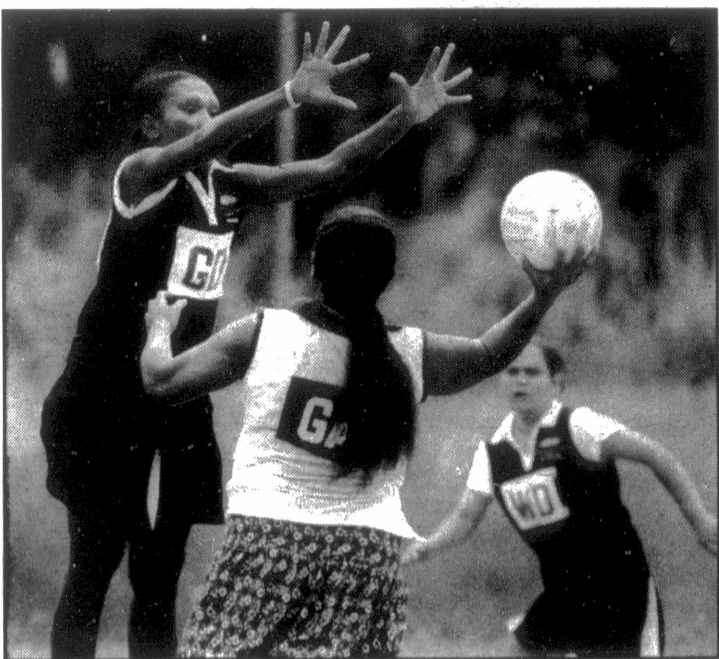

PAINIM BAL RESIS

ISU NAMBA 1801

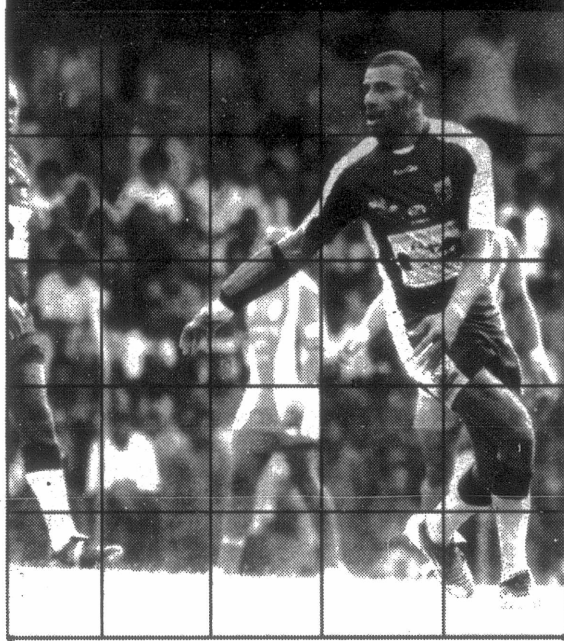

NAMBA - 6

Putim mak (X) long wanem hap yu ting bal i stap long en na salim i kam long:

**PAINIM BAL RESIS
WANTOK NIUSPEPA
P.O. Box 1982 Boroko,
NCD
Port Moresby.**

Bai yu gat sans long winim K100 long wanwan mun. Traim lak bilong yu, nogut yu gat sans long win!!!

Lo bilong resis:
Ol wokmanmeri bilong Wantok Niuspepa no inap pital long dispela resis. Wantok Niuspepa tasol bai i makim wina. Nogut potokopi. Taim bilong dro em bihain long foapela wik bai ol i droim wina na nupela pital bai i stat gen. Nem bilong wina tas kamaul long papa nekai wik bihain long dro.

**Sans
K100
yah!!**

Makim (X) long bokis yu ting bal i stap na salim i kam long atres antap..

Nem:.....Krismas:.....

Man/Meri:.....Atres:.....

.....Telepon Namba:.....

Yu baim Wantok pepa long we?

Stua/Maket/Strit:.....

katim long hia

PAINIM BAL RESIS

ISU NAMBA 1797



NAMBA - 5

Putim mak (X) long wanem hap yu ting bal i stap long en na salim i kam long:

**PAINIM BAL RESIS
WANTOK NIUSPEPA
P.O. Box 1982 Boroko,
NCD
Port Moresby.**

Bai yu gat sans long winim K100 long wanwan mun. Traim lak bilong yu, nogut yu gat sans long win!!!

Lo bilong resis:
Ol wokmanmeri bilong Wantok Niuspepa no inap pital long dispela resis. Wantok Niuspepa tasol bai i makim wina. Nogut potokopi. Taim bilong dro em bihain long foapela wik bai ol i droim wina na nupela pital bai i stat gen. Nem bilong wina tas kamaul long papa nekai wik bihain long dro.

**Sans
K100
yah!!**

**WINA BILONG PAINIM
BAL RESIS No. 5 em:**

**PETER NALI
KISAN LIMITED
P.O. BOX 353, VANIMO
MOBAIL: 637 0914**

katim long hia

LAE
BISCUIT CO.



Isu 1801

WANTOK

S P O T S

LAE
BISCUIT CO.



Wan wik: Fonde, Febuari 12 - 18, 2009



Local calls from Landline to Mobile is...
MUCH, MUCH CHEAPER!

MASSIVE
SAVINGS

82^t peak hrs

49^t off-peak

The cheapest calls in Papua New Guinea

TELKOM PNG LIMITED
Always there!

HANGRE: Kimbe pilaia i painim sapot long 2007 PNG sevens long Mosbi. Ol i winim pinis tupela sevens taitol na nau bai ol i traim PNG sevens taitol long Mosbi dispela wiken.

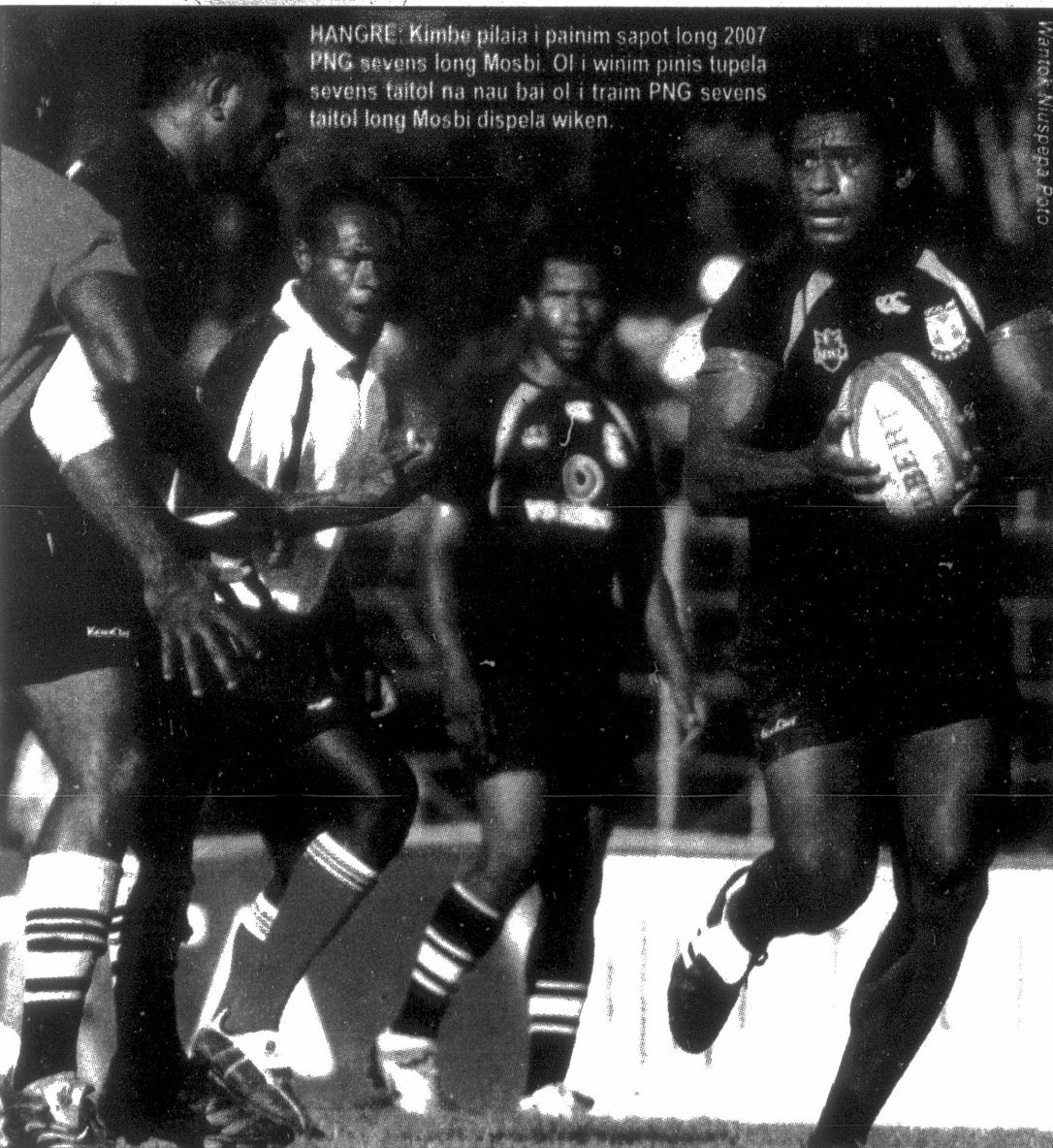

Wantok Nusepe's Photo

Kimbe em 7's fevret

Ol i winim pinis tupela taitol...

KIMBE em ol fevret bilong winim PNG ragbi yunion sevens (7's) resis dispela wiken long Mosbi.

Ol i winim pinis Bismark kap long Niugini ailans na tu Black Orchid sevens long Bogenvil na las wiken ol i go ken long fainol bilong Rookie sevens resis long Mosbi.

Kimbe i holim taitol bilong 2007 PNG sevens na dispela yia

bai ol i pait long kisim bek dispela taitol.

Ol bikpela na strongpela pilaia bilong ol i gat planti spit na pawa na i save givim hat taim long ol tim bilong ol arapela ples insait long kantri.

Arapela ol tim bai kam long ol ples insait long kantri husat ol i holim ragbi sevens resis bilong ol long pinis bilong las yia na i mekim seleksen bilong ol.

Sampela bilong ol tim we bai kamap long dispela tonamen em Mosbi, Lae, Madang, Aroma, Kavieng na Kimbe yet.

Kimbe i soim strongpela gem bilong ol taim ol i kamap long Rookie 7's las wiken na dispela wiken bai ol i kirapim das long Mosbi gen.

Nandex bai bungim 'White Sniper' gen. PES 27.

BOROKO MOTORS

MIPELA IGAT OLGETA KAIN PATS BILONG
INAPIM OLGETA KAIN KAR

Istap nau...

Hevi Diuti brek peds bilong E25 Urvan Bas.

SPE PATS



K103.40

Port Moresby ph: 325 5255 Lae ph: 472 1144 Mt. Hagen ph: 542 1933 Rabaul Ph: 982 8193 Madang Ph: 852 2659 Kimbe Ph: 548 9048 Tabubil ph: 548 9048 Email: info@borokomotors.com.pg Website: www.borokomotors.com.pg

Wantok

Digitized version made available by



Copyright: Under copyright

Rights Holder: Word Publishing Company Limited

Use: This digital version is made available from the UC San Diego Library under a license granted by the Word Publishing Company Limited. This digital copy of the work is intended to support research, teaching, and private study.

Constraints: This work may be protected by copyright law. Use of this work beyond that allowed by the applicable copyright statute requires the written permission of the copyright holder(s). Responsibility for obtaining permissions for any use and distribution of this work rests exclusively with the user and not the UC San Diego Library. Inquiries can be made to the UC San Diego Library program having custody of the work.

Note on digitized version: Some of the digital versions presented here reflects the quality and contents of the microfiche. Problems which have been identified include misfiled or out-of-order pages, illegible text; these problems have been rectified whenever possible.