



Niuspepa bilong ol Papua Niugini stret

Wantok 12t

Namba 312 Bilong wikipita long Sarew, 26 Epril, 1980

Nupela

Flak bilong Niu Hebrides

p.9

Wok Timba p.3

Wattpo Indai?

Long Fraide 11, Epril, Daniel Kaumi Tuvi i no save olsem em bai indai insait long wanpela ragbi gem long Rabaul. Daniel i wok long pilai wantaim tim bilong em Gaselle Pantas. Tasol, i no longtaim na boi ya i slip long pilai graun i stap. Em i dai pinis.

Planti toktok i kamap nau long spot. Sampela man i tok, spot i birua long planti spotman nau. Ol i tok, ol spot i bagarapim bodi bilong ol spotman.

Bihain long Daniel indai, Dokta Tim van Zwanenberg i sekap long bodi bilong em na tok, em i dai taim liva long bodi bilong em i bruk. Ol wantok bilong em i tok, Daniel i sik long wan wik olgeta na em i orait liklik taim em i go pilai.

Dokta Zwanenberg i salim tok lukaut long ol spotman bilong olgeta kain pilai. Em i tok, sapos man i painim sik fiva o wanem kain sik i tambu tru long go insait long pilai.

Olsem tasol na Is Niu Briten provinsal gavamn i putim tambu pinis long olgeta provinsal hai skul long Is Niu Briten long pilai ragbi. Ol i ting, pilai ragbi i save bagarapim planti pilaia na kilim sampela arapela tu.

Ragbi mas kamap

Is Niu Briten Ragbi Lig i salim pinis wanpela pas i go long provinsal gavman. Ol i tok, sapos gavman i tambuim ragbi long ol skul nau, bihain bai moa bagarap i kamap long ol pilaia. Ol i askim provinsal gavman long rausim dispela tambu ol i putim long ol skul.

Is Niu Briten Ragbi Lig i tok, sapos ol

sumatin i no lain long dispela pilai long skul, ol lain husat i tambuim ol long pilai nau bai sori bihain.

Ol bai sori taim ol i lukim planti bilong ol i kisim bagarap long dispela pilai. As tru bilong ol i kisim bagarap em long wanem, ol i no lain gut long pilai bilong ragbi.

Sutim Tok

Is Niu Briten Ragbi Lig i sutim tok i go long ol tisa. Ol i tok, ol skul i les long skulim ol sumatin long pilai ragbi. Ol i tok, "Mipela bilip olsem ol sumatin bai lain moa sapos ol i lain long olkain spot taim ol i stap long skul."

Ol i tok, planti ragbi pilaia i slek tumas. Long wanem, dispela tambu tasol i daunim laik bilong ol long lainim gut pilai taim ol i stap yet long skul.

Tasol, tupela skul boi i slip long haus sik nau. Ol i wok long tingting na driman long wanem taim bai ol i wokabaut na pilai gen.

Wanpela em, Remus Aken. Em i brukim nek bilong em insait long wanpela ragbi gem taim em i skul i stap long



Pilaia bilong Kone na Wes i karim blanket raun long Boroko ragbi graun. Ol i kisim mani long ol pipel i was long pilai. Ol i bungim samting olsem K175.99. Dispela mani bai go long helpim Remus Aken husat i kisim bikipela bagarap long ragbi pilai long Aiyura sinia hai skul long yia 1979.

Aiyura Nesenal Hai Skul long las yia. Em i slip nau long wanpela haus sik long Australia. Em i no inap wokabaut. Olgeta bun bilong em i dai pinis. Remus i wanpela smatpela man bilong pilai ragbi.

Aiyura sinia hai skul, Ragbi lig asosiesen na planti arapela kampani na pipel i wok long bungim mani nau long helpim Remus. Samting olsem K4,000 i kamap pinis long dispela fan ol i kolim, Remus Helpim Fan.

Autim Bos

I gat wanpela bikipela tok kros i kamap namel long Namba Tu Praim Minista na Minista bilong Transpot Mista Okuk, na ol bos bilong Air Niugini.

Nau Mista Okuk i rausim pinis bikipela bos bilong Air Niugini, Mista Gerald Fallscheer, inap long taim em i singautim em gen.

Wanpela skulboi nau. Em i brukim em, Limbie Kelagai. Em i wanpela mekenik sumatin long Yunivesiti bilong Teknoloji. Em i slip nau long Angau haus sik long Lae. Em tu i no inap wokabaut

Smatpela man i save baim sea long Invesmen Koporesen

Sapos yu laik save moa rait i kam long

Investment Corporation of Papua New Guinea

P. O. Box 155, Port Moresby.





SKELIM GUT WOK

Long las wik memba bilong Midel Flai, Misis Waliyato Clowes i tok aut long kirapim wanpela nupela politikal pati. Nem bilong dispela pati em Panal (Papuan Nesenal Alaiens). As tingting bilong dispela pati em long lukautim na helpim ol pipel long hapsait bilong Papua.

Tasol i luk olsem lida bilong Panal Pati na ol memba Palamen i go insait long dispela pati, laik kisim wok bilong Provinsal Gavman. Tasol ol dispela hap i gat Provinsal Gavman pinis. Sapos i no gat Provinsal Gavman orait kain pati olsem Panal i gat as bilong en. Tasol i luk olsem nupela pati, laik resis wataim Provinsal Gavman.

I no Panal tasol i luk olsem yumi i gat planti ol liklik pati nabaut insait long PNG. Tasol i no pati tru. Ol i pati bilong kirapim as ples bilong memba husat i gat nem long dispela pati.

Ol i no pati bilong tingting tumas long kantri bilong yumi. Ol i wari long as ples. Na sapos ol i gat taim orait ol i wari long kantri bilong yumi.

Tasol, sapos ol pati na ol memba bilong palamen i wari long asples tasol, husat bai wari long kantri bilong yumi. Provinsal Gavman i stap long helpim na pinisim ol wari bilong ol provins. Nesenal Gavman i stap long stiaim kantri. I no stret tumas sapos tupela i miks nabaut.

Ramu Suga

PNG bai inap tru long kamapim suga bilong em yet long yia 1983. Long olgeta yia PNG inap kamapim 40 tausen tan suga olgeta. Jeneral menesa bilong Ramu Suga, Mista Arthur Beevers, i tok ol i laik hariapim wok planim suga. Olsem bai suga i redi long taim ol i pinisim wok long wanpela faktori bilong wokim suga.

Wanpela kampani bilong Japan, Itoh-Kawasaki Indastris i winim pinis kontrak long kirapim faktori bilong wokim suga. Dispela faktori bai i stap insait long Gusap long Markham, Morobe Provins. Kampani ya i ting faktori bai redi long wok long yia 1983. Kampani bai tromoi

K23 milien long kirapim faktori.

Dispela kampani i gat planti save tru long kirapim dispela kain faktori. Ol i kirapim dispela kain faktori long Panama, Pakistan, Indonesia, Philipines na sampela arapela kantri.

Long Fonde Epril

10, sekreteri bilong Dipatmen bilong Prameri Indastri (DPI) na siaman bilong Ramu Suga Kampani, Mista William Lawrence i sainim wanpela tok orait wantaim dispela kampani bilong Japan. Em i givim tok orait long ol i kirapim dispela faktori.

● Ben Kasanda



Kampani bilong Japan, C. Itoh-Kawasaki i sainim tok orait long kirapim Suga Faktori long Gusap wantaim Ramu Suga Siaman. Ol sindaun kirap long lephan: Mista Hiroshi Morita, Mista Ichiroku Amemiya na Siaman bilong Ramu Suga Dairektas, Mista William Lawrence.

i kam long pes 1

daun long het bilong em.

Limbie em i bilong lalibu insait long Sauten Hailans. Yunitek na tim bilong em Wes Pantas, na arapela asosiesen i bungim mani nau long salim em i go long haus sik long Australia. I luk olsem em tu bai i no inap kirap na wokaabout long wanem, olgeta rop long bun i

Watpo Indai ?

dai pinis.

Lae Ragbi Lig i tok, Limbie i no rejista long pilai na insurans kampani i no inap givim helpim long em.

Namba wan spots opisa insait long Spots Opis long Mosbi, Mista Kevin Murphy i tok, sapos Edukesen Dipatmen i bringim bek dispela skul ol i

kolim Fisikal Edukesen long ol skul, dispela kain birua i no inap kamap. Em i tok, planti bilong ol spotman i no tren gut long pilai spot. Olsem ol i kisim bagarap kwiktai. Mista Murphy i tok, dispela ol birua i kamap pinis long ragbi i soim olsem ol spotman i mas fit tru, taim ol i laik pilai. ● Ben Kasanda

TAMBU TORO

TORO LUKIM WANPELA WANTOK BILONG EM KARIM OL BUK IKAM...



YU SAVE LONG RITIM BUK



NOGAT, MI NO SAVE LONG RIT NA RAIT.



NIUS-NIUS-NIUS

☆ HAILANS SO – Isten Hailans So bilong yia 1980, bai kamap long namba 12 na 13 de bilong mun Julai. Pastaim ol i laik putim So long mun Septemba tasol ol i senisim ken. Ol pret nogut So i pasim ples bilong dispela Nesenal Sensus i laik kamap.

☆ TAMBU LONG PILAI – Sapos yu gat sik, o nau tasol sik i pinis, yu no ken pilai spot. Dokta Tim Van Zwanenberg, i tok olsem taim em i sekap long bodi bilong wanpela ragbi pilai Daniel Tuvi, husat i dai long Rabaul. Daniel i dai taim em i gat sik malaria na pilai ragbi long Rabaul long las wik.

☆ STAP LONG PLES – I tambu long ol memba bilong Madang Provinsal Gavman long go raun. Provinsal Gavman i tambuim ol long go raun long ol arapela provins o ovasis kantri. Ol i tok pastaim ol memba i mas kisim save long Madang Provins na we bilong helpim ol pipel bilong Madang yet.

☆ OL MEMBA RAUN – Planti ol memba na wokman bilong Niu Ailan Provinsal Gavman i go nau long raun long ol arapela provins, na ol arapela kantri. Primia, Mista Robert Seeto, i lukluk long sampela pis faktori long Amerika, Samoa na Fiji. Minista bilong Helt, Mista Maul Karau, na wanpela opisa bilong provinsal gavman, Mista Robin Teke, i go wantaim em. Long mun Me, bai 5-pela man i go lukluk long wok timba long Japan.

Nau tu 5-pela memba i wok long lukluk raun long ol hailans provins.

☆ NUPELA PATI – Memba bilong Midel Flai, Misis Waliyato Clowes, i kirapim pinis wanpela nupela pati. Nem bilong pati em Panal. Panal i sotpela tok long Papua Nesenal Alaiens. Em i tok i luk olsem pati bai i gat 10-pela memba samting. Em bai tokaut klia long ol nupela memba bipo long kibung bilong Palamen long mun Jun.

☆ OL SIOS LIDA KIBUNG – Bikpela lain sios lida bilong planti kain lotu na kantri bai kirapim wanpela bikpela kibung long Mari Bareks, Mosbi long Mande, Epril 28.

Ol i kam long ol lain sios bilong Melanesian kaunsil bilong ol Sios, na bilong Evanselikel Alaiens. Ol i kam long Yurop na long Saut Amerika na long Indonesia na long Australia.

As tok bilong dispela kibung em “Kingdom Bilong Yu i Kam.” Ol i kisim dispela nem long beten “Papa bilong mipela.”

Pater John Momis, Minista bilong ol provins, bai givim namba wan toktok long dispela kibung. Na bai Nesenal Redio i putim lotu bilong dispela kibung i go long redio long 5 klok Mande Epril 28. Lotu bai kamap long Ragbi Lig Graun, Mosbi. Bai samting olsem 150 manmeri i bung long dipsela.

☆ TAIM BILONG MASTA – Wanpela nupela progrem bai kamap long redio Australia. Nem bilong dispela progrem em Taim Bilong Masta. Dispela progrem bai kamap long yia 1981. Ol wokman bilong redio i mekim wok nau long kisim ol toktok bilong ol waitman na PNG manmeri.

Tram Borneo Piksa Nau!

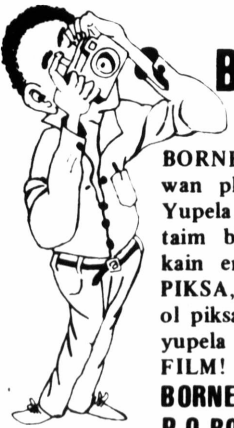

BORNEO PIKSA, em i namba wan ples bilong wasim piksa. Yupela salim ol Kala film wantaim blak/wait films, na kain kain eni film kam. BORNEO PIKSA, bai developim na prinim ol piksa, na salim i go bek long yupela wantaim nupela FRI FILM!

BORNEO PIKSA HELDSBACH
P.O. BOX 217 FINSHAFEN

WANTOK NIUSPEPA

Nius i kamap 52 taim long yia nau.

Opis bilong Edita na Edvetaising long P.N. G.
P.O. Box 1982, Boroko
Telipon: 25.2500 Teleks: NE 22213

Edvetaising long Australia
Central Media Sales, Sydney
Telipon: 436.1000 Teleks: AA23211

PE BILONG WANPELA YIA, 52 NIUSPEPA

Ples	Kam long balus	Long sip
Mosbi	K 10.00	K 10.00
P.N.G.	K 14.00	K 14.00
Australia	A\$ 36.00	A\$ 29.00
N.Z., Fiji		
Pasifik Ailan	NZ\$47.50	NZ\$ 32.00
USA, Yurop	US\$ 70.00	US\$ 47.00
	DM 120.00	DM 81.00
	L 31.00	L 21.00

Wok Timba

Insait long Mosbi, long wik i go pinis, wampela so bilong soim olkain samting ol i wokim long timba i kamap. Dispela so i stat long Fonde Epril 17.

Praim Minista Sir Julius Chan, na Mista Josphe Aoe na Minista bilong Nesenal Plening na Dvelopmen, Mista Galeva Kwarara, ol i bin stap long opim dispela so. Ol bikman bilong gavman na ol sampela bisnismen tu i stap long dispela so.

Wampela kaunsil bilong lukautim ol wok

timba, (Fores Indas-tris Kaunsil) i bin putim kamap dispela so. Ol i laik tokaut long ol PNG pipel olsem, planti samting ol i wokim long timba i stap wetim ol long PNG stret. Bilong wanem na ol i odaim ol kain samting olsem long ovasis. Dispela so em i pinis long Epril 19.



Minista bilong Bosim Bikbus, Mista Joseph Aoe wantaim ol sampela arapela man i lukim bikpela so bilong katim diwai. Minista i sanap namba tu long lephan.

Helpim ol Provins

Nesenal Gavman i laik givim moa helpim long ol provins. Olsem gavman i senisim pinis wok bilong Dipatmen bilong ol Provins.

Bipo, dispela dipatmen i gat planti kain kain wok. Em i bosim Opis bilong Komyuniti Dvelopmen (Hom Afeas). Na tu em i gat planti wok kuskus.

Bipo tu, dispela Dipatmen i bosim ol kalabus bilong ples, na planti ol yut wok na wok welfea. Na em i wok wantaim ol pablik sevan insait long ol provinsal gavman.

Tasol, Minista bilong ol provins, Pater John Momis, i laik mekim moa wok long helpim ol provinsal gavman i go het.

Olsem Gavman i tok orait long senisim sampela wok insait long Dipatmen bilong ol Provins. Nau ol wok olsem komyuniti dvelopmen na provinsal afeas na yut

wok i go long Dipatmen bilong Hom Afeas.

Na tu, Dipatmen bilong ol Provins i senis na i kamap Opis. Opis hia bai wok long helpim ol provinsal gavman tasol. I no ken holim ol dispela arapela wok moa.

Opis ya bai wok long givim save long ol provinsal gavman long lo, long wok plening, long we bilong wokim komyuniti gavman, na long sampela arapela samting olsem.

Na tu bai Opis ya i helpim ol provinsal gavman toktok wantaim nesenal gavman, na autim ol wari bilong ol i go long nesenal gavman.

Draipepla Kanu Kam Pinis

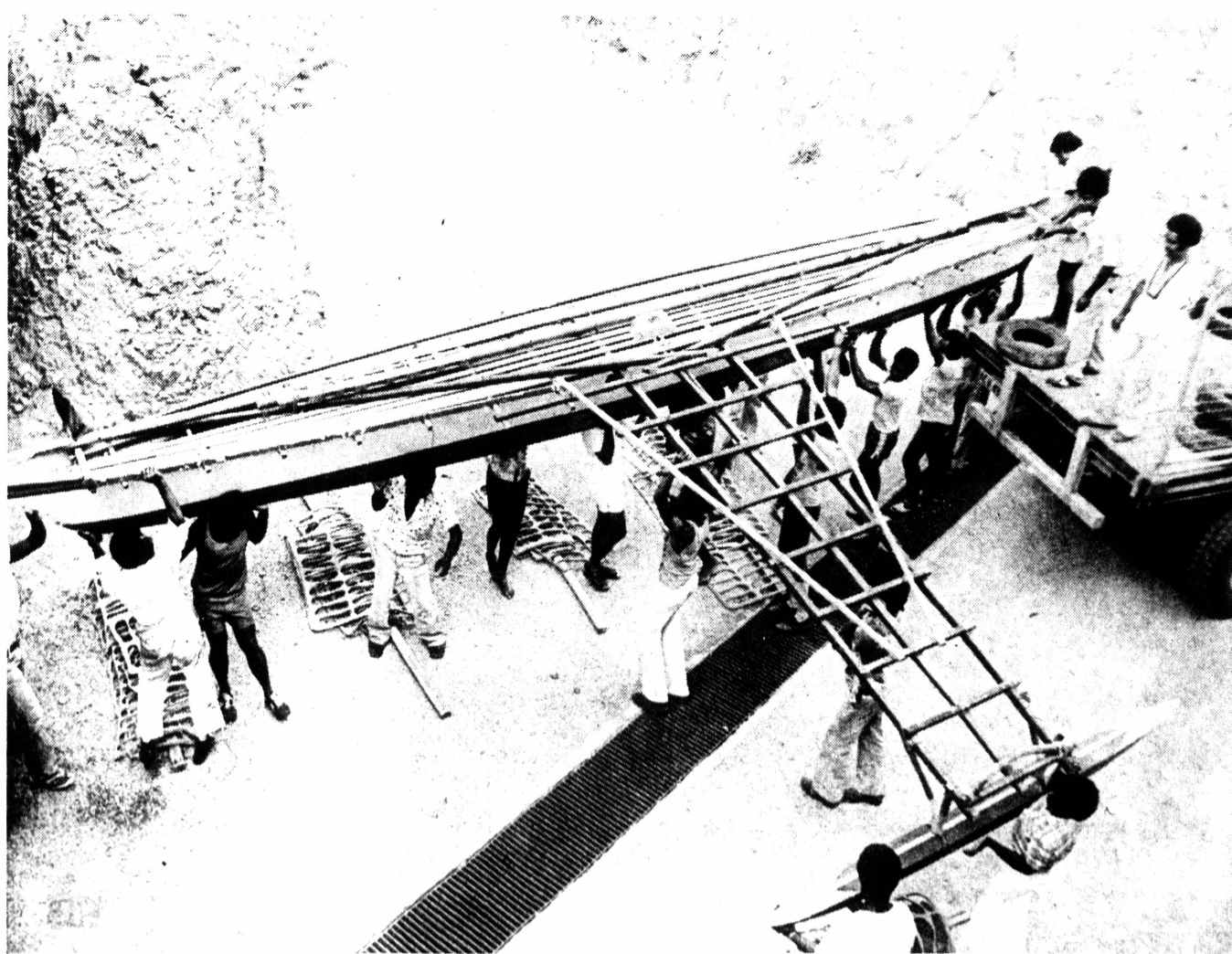

Dispela piksa i soim ol sampela wokman bilong nesenal musium rausim draipepla kanu long trak. Kanu ya nem bilong em, "VICTORY." Ol i rausim long trak na ol bai putim i stap long musium wetim Saut Pasifik Festival ov Ats long Jun. Gavman sip bilong Kiribati, Tuaka, em i bin kisim Victory long Kiribati na sel i ka kamap long Mosbi long Trinde, namba 9 de bilong mun Epril.

Victory bai sel wantaim planti arapela kanu. Ol dispela kanu bai sel long taim bilong Saut Pasifik Festival ov Ats Na ol bai stat long Samarai na katim solwara bilong Papua i kam kamap long Mosbi. Ol bai stat stret long ailan Misima long Milen Be. Narapela draipepla kanu tu i kamap pinis long Mosbi. Dispela kanu em i kam stret long ailan kantri bilong Tuvalu. Tupela kanu wantaim i stap long musium wetim tasol bikpela de bilong ol i sel.

Putim Kristen Nem Nating

Dia Edita — Inap yu givim spes long mi. Mi laik bekim pas bilong wantok ya, William Baimo bilong Rabaul.

Yu tok long ol yangpela meri i paul wantaim ol man, na kisim pikinini na ol i putim kristen nem em i no stret.

Brata, ating yu no tok stret, long wanem ol man na meri i ken

putim nem bilong ol pikinini long laik bilong ol yet.

Na brata, ating yu save go long Lutren sios o katolik sios, em ol mama i save kisim pikinini bebi yet na ol i kisim i go long sios na ol i putim wara long het bilong ol, na ol putim kristen nem. Brata em i no stret.

Brata, ating yu save long pasin bilong kris-

ten. Kristen em i olsem, man i bilip long Jisas na kisim baptais aninit long wara, na em lusim olgeta pasin nogut. Em dispela man i kristen. Brata, yu longlong long kristen na mi tokim yu.

Na yu tok, no ken putim kristen nem long pikinini bilong God. Jisas em tu i no kristen nem, man i bilip tasol i kristen man.

Em tasol na tenkyu tru na God bles yu.

Kulg Siune, Simbu Kundiawa, Provins.

Salim ol pas i kam long:

WANTOK
BOX 1982
BOROKO

Nes i No Givim Marasin

Dia Edita — Plis inap yu givim mi liklik spes na mi laik bekim pas bilong wantok ya Steven Toba bilong Goroka. Pas bilong em i stap long Wantok Niuspepa bilong Sarere, 22 Mas, 1980.

Wantok ya i bin rait na tok ol nes i no save givim gut marasin long ol lapun man. Ol save givim marasin long ol yangpela man na boipren bilong ol tasol.

Steven inap yu tok stret long wanem hap bilong hausik tru yu bin lukim ol nes i givim rong marasin long

ol sikman? Sapos ol i givim rong marasin long yu, inap yu stap? Aste yet inap yu slip 6 fit aninit long graun.

Narapela taim yu laik rait yu mas kolim stret nem bilong wanem hausik yu bin lukim ol nes i givim rong marasin long ol sikman o toktok wantaim ol boipren bilong ol, no ken toktok long olgeta nes long Papua Niugini.

Wantok, ating yu mas i gat liklik bel hevi o yu mas jeles long ol nes na yu raitim kain pas olsem. Nau

Gut

yu gutpela na yu hambak. Sapos wanpela hap bodi o skin bilong yu i bagarap bai yu go we? Yuman wok-sop i stap, kam wok nes orait yu painim aut, em isipela wok o nogat.

Em tasol. Husat i gat liklik wari long dispela pas yu ken rait tasol long Wantok Niuspepa na bai mi ken lukim. Tenkyu.

Labia Tewa, Is Sepik Provins.

Plis Mekim Wanem

Dia Edita — Inap yu givim mi liklik spes bilong mi autim wari bilong mi?

Wari bilong mi i go olsem. Planti taim mi save lukim ol plisman i save kisim ka na i go raun na painim meri long ol rot. Em olsem wanem? Long tingting bilong mi em i no gutpela long painim meri long taim ol i wok. Mi ting olsem i moa gutpela long mekim long wiken.

Na tu mi save lukim ol save askim nabaut ol meri i save



wokabaut long rot wantaim susa o gelpren long rot. Olsem na mi pilim dispela pasin i no gutpela. Olsem wanem? Ol bos bilong ol plis i save lukim tu o nogat? Mi ting olsem ol i save hait long bos na ol i save wokim dispela pasin. Olsem na mi ting ol bos i save i stap tasol long wanpela hap, ol i no save raun na lukim ol plisman i wok.

Em tasol liklik wari bilong mi. Sapos yu husat man o meri i laik bekim pas bilong mi, em orait tasol. Rait tasol long Wantok Niuspepa na mi ken lukim. Tenkyu.

Sam J. Moses, Madang Provins.

Jeles Long Saveman

Dia Edita — Inap yu yu givim mi liklik spes long bekim pas bilong wanples ya, Pius Kakunambi bilong Aitape, WSP. Pas i kamap long Sarere Mas 15, 1980. Em i tok long ol meri i maritim ol saveman tasol.

Yes Brata Pius, mi laik save, yu bilong Aitape stret o yu bilong arapela hap olgeta?

Pius, mi ken tokim yu stret olsem, ol meri Aitape o ol meri bilong Wes Sepik, ol i no save laikim ol lesman. Ol i save laikim ol man i wok hat long gaden na ol man i wok hat long liklik bisnis o ol man i wokmani. I no ol saveman

tasol i save wokmani. Nogat.

Wantok bilong mi Pius, i luk olsem yu wanpela lesman tru. Olsem na ol meri wantok bilong mitupela i daunim nem bilong yu. Sapos yu kain man bilong wok gaden o wok bisnis, em aste yet. Ol meri i no inap tokim yu long wanpela tok. Em bai yu kirap nogut tasol na lukim wanpela i kam stap pinis long haus bilong yu wantaim papa mama bilong yu.

I no olgeta meri Wes Sepik i save laikim ol saveman tasol. Wan wan bilong ol tasol. Olsem olgeta hap bilong PNG, em ol meri i save laikim ol man i save wok. Ol i no laikim ol lesman.

Luke P.C. Saipera. Wewak, Is Sepik Provins.

Pai Nogut

Dia Edita — Inap yu givim liklik spes long autim liklik wari bilong mi.

Long 29 Mas 1980 mi baim tupela pai na loliwara. Na mi go sindaun na amamas long kaikaim.

Bihain mi brukim na mi smelim pai i smel nogut. Olsem na mi tromoi.

Yupela olgeta pipel i go baim pai long stua, yupela i mas brukim na smelim gut pastaim, orait kaikai.

Peter Manus, Man Bilong Raunim Lon Mowa.

Larim Somare, O Okuk Wok

Dia Edita — Plis givim mi liklik spes bai mi putim wari bilong mi long Wantok Niuspepa bilong yumi. Yes, wari bilong mi i go olsem.

Mi sapotim Mr. T. Juna Mu Sorohao, bilong Finschafen Distrik.

Wari bilong mi olsem. Sapos mi singel man, em i orait tasol. Risen bilong em olsem. Sapos wanpela kantri i laik kam pait long yumi, em i orait tasol long mi kirap na ranawe o go hait. Tasol nau mi marit, na mi gat tupela pikinini. Sapos wanpela kantri i laik pait wantaim yumi bai mi kirap ranawe o mi ting i go bek long pikinini.

Plis ritim gut dispela pas, na em i gat mining tu i go long tupela gavman nau. Wanpela em Somare Gavman, na wanpela em PPP Gavman.

Somare Gavman i bin lukautim kantri bilong yumi, long yia 1972 inap long 1979 na i no gat pait long kantri bilong yumi. Na yumi stap amamas tasol. Na nau, PPP Gavman i laik lukautim kantri bilong yumi, na (Lukaut).

R. Samy Arawa.



Tolai i Hatwok

Dia Edita — Mi no stret. I no stret na yu tok olsem, mipela hapkas Saina. Em i olsem wok mani bilong yu?

Mi ting, tok bilong yu i rong tru. Tasol mi tokim yu. Yu inap, nau tasol yu kirap na i go long maket long Rabaul na lukim. Em i olsem maket bilong yu long Sepik o olsem wanem.

Mi save i go long maket bilong yu na maket bilong yu i no olsem Rabaul maket. Yupela i save salim hap buai na wanpela daka long 20t. Em i

Em tasol liklik bekim bilong mi. Sapos yu laik bekim gen, em i orait. Rait i kam na mi lukim.

John ToGoragoro Is Niu Briten Provins.



MIPELA SAVE MEKIM OLKAIN WOK BILONG BENG

- ☆ Pas Buk
- ☆ Sek Buk
- ☆ Man i ken putim mani long beng na winim profit mani
- ☆ Sapos yu kisim narakain mani bilong wanpela arapela kantri, beng i ken senisim i kamap kina na toea.
- ☆ Ben i ken stretim olgeta tiket bilong yu, sapos yu laik go lukluk raun long arapela kantri.

W Bank of New South Wales (PNG) Ltd.

Mipela amamas tru long helpim yu



Sampela patpela kakaruk bilong bisnis grup.

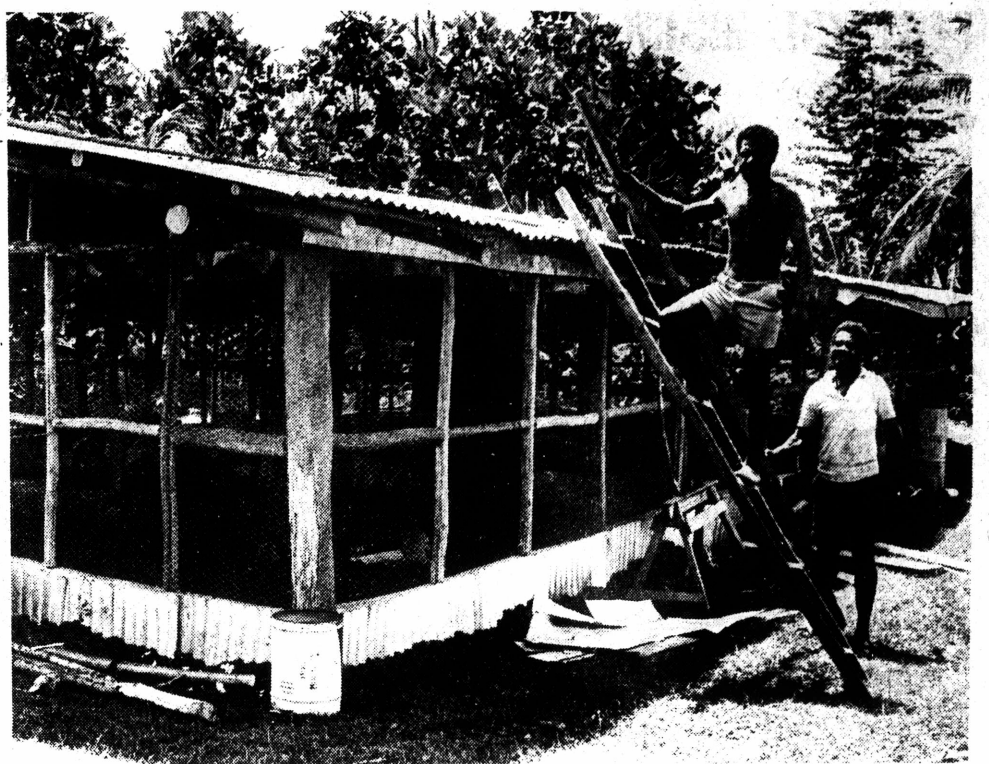

Ol bisnis grup i wok long skruim haus kakaruk i go bikpela bai ol inap kisim planti kakaruk.

Togarari Bisnis Grup

Wanpela viles bisnis grup, Togarari Invesmen Koporesen, ol i kirapim wanpela kakaruk fam pinis klostu long Mosbi.

Ol pipel bilong Osabea viles insait long hap bilong Koiari kaunsil i kirapim dispela wok. Ol i kisim sampela helpim i kam long Niu Silan Gavman na tu long Pot Mosbi Komyuniti Developmen Grup. Niu Silan Gavman i givim ol K600.

Pastaim dispela grup i askim Opis bilong Viles Developmen long helpim ol. Tasol ol lain bilong Viles Developmen i tokim ol olsem, dispela wok i no inap kamap gutpela. Olsem na nogut mani bai lus nating long wok.

Tasol ol pipel i no wari. Ol yet i statim wok long han bilong ol yet na long helpim i kam long tupela lain ya. I no longtaim i go pinis, man i wok olsem hai komisina bilong Niu Silan long

hia, Mista Paul Shanahan i go lukim dispela wok. Em i go sekap na lukim kain wok ol pipel i mekim long dispela K600 Niu Silan Gavman i givim ol pinis.

Em i amamas tru long dispela wok. Na em i tokim ol man meri bilong Osabea viles olsem, Niu Silan Gavman i amamas tru long helpim ol wok gohet long ol viles long PNG.

Na ol pipel tu, i amamas tru long helpim bilong Niu Silan

Gavman. Kaunsila, Arogo Arau i sanap makim ol pipel na bisnis grup na em i tok tenkyu long Mista Shanahan.

Togarari bisnis grup, em i salim moa long wan tausen kakaruk i go pinis long Ilimo Fam. Na las wik Ilimo Fam i salim 700 nupela liklik kakaruk i go long ol.

Kaunsila Arau i tok, mani ol i kisim bilong salim kakaruk, ol bai putim long



beng. Ol i no save long wanem samting ol bai mekim long dispela mani yet.

Nau, ol man bilong ples i wok long mekim haus kakaruk i go bikpela. Ol i laik skruim moa yet olsem bai ol inap lukautim moa kakaruk.

● Franzalbert Joku

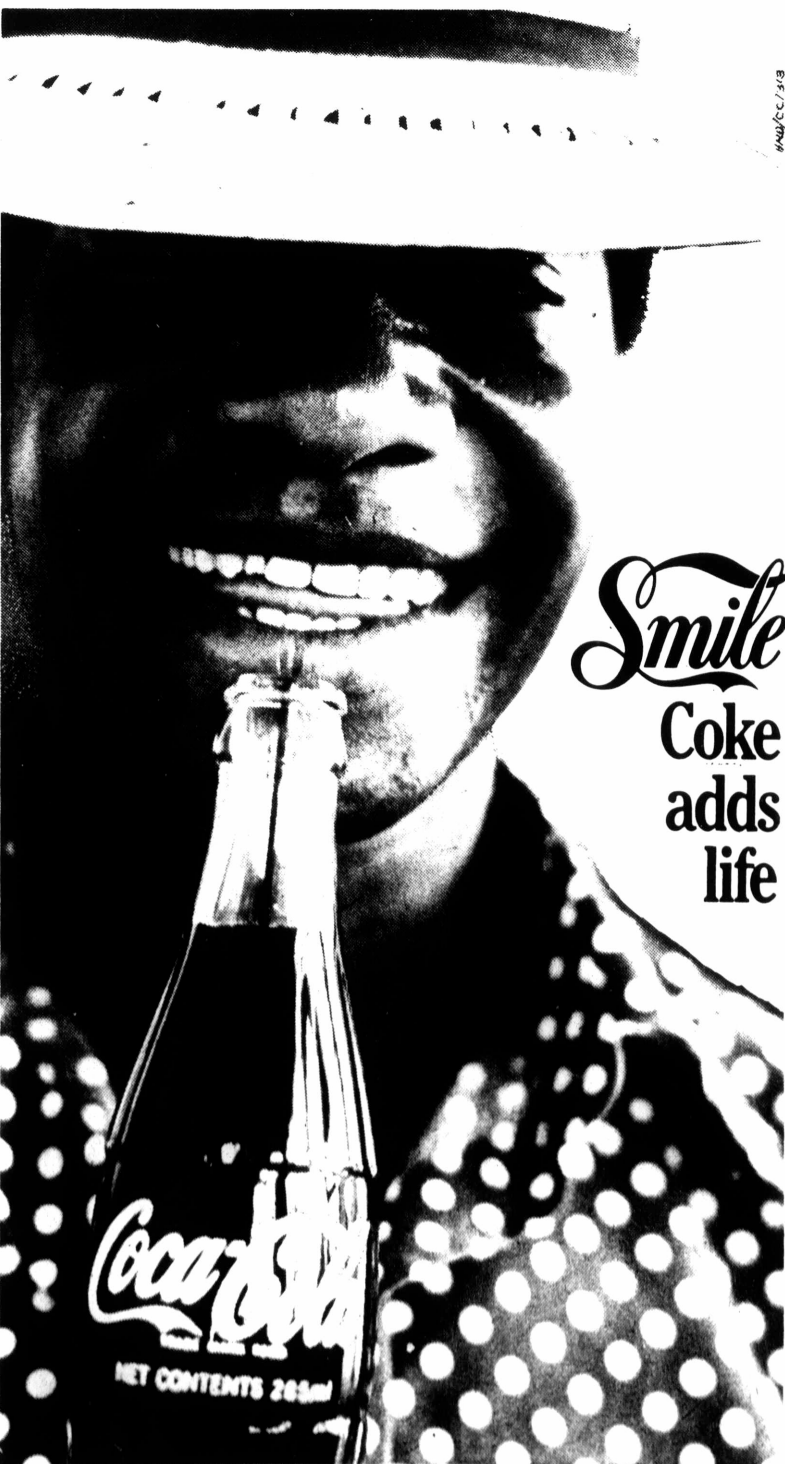

Praim Minista, Sir Julius Chan, tromoi sampela tok long ol pipel, taim kabinet i bung long Rabaul long Epril 9. Namba tu Praim Minista, Iambaki Okuk sindaun i stap klostu long Sir Julius.

FESTIVOL KISIM MANI

Ol pipel bilong Mosbi i givim K10,000 (ten tausen kina) pinis long Saut Pasifik Festival ov Ats. Long poto, Lot Meya bilong Mosbi Siti Kaunsil, Mista Kipling Uiari (lephan) i givim K10,000 sek i go long Dairekta bilong dispela Festival Mista Mali Voi. Mista Uiari i givim sek long siti kaunsil opis long Mande, Epril 14.

Taim em i givim sek em i tok Siti Kaunsil i laik tru long helpim dispela pestode i go het. Em i tok siti kaunsil i putim pinis K5,000 long mekim siti i kamap klin na wokim arapela pestode long mun Jun. Mista Uiari i tok, siti kaunsil i kisim dispela mani long wanpela fan bilong ol yet na em i mani bilong ol pipel.



Kipling Uiari na Mali Voi

FRUT NA SAYOR FAM

Is Taraka, wanpela setelmen autsait tasol long Lae Siti i kamap ples tru bilong kamapim kaikai. Lae Siti Kaunsil i statim pinis wanpela fam long Is Taraka bilong planim olkain frut na sayor.

Tok orait bilong dispela projek i bin kamap long 1978, long mun Julai. Dispela wok, em i gat as tingting bilong painim na kamapim gutpela kaikai. Long wanem PNG i gat planti kain kain frut na sayor. Sapos ol dispela samting inap gro gut long Is Taraka, orait, ol bai tokaut long ol na askim planti pipel long traim planim.

Ol i stat planim ol samting long Ogas 1978. Graun bilong dispela wok i bikpela olsem 3.5 hekta.

Olkain frut na sayor bilong planti hap bilong PNG i gro nau long dispela fam. Sampela frut na sayor tu i kam long arapela kantri. Na planti bilong ol dispela samting i karim gutpela kaikai tru.

Pikinini diwai frut na sayor, ol didiman i wokim bilong karim planti gutpela kaikai. Ol dispela pikinini diwai i gro nau long Is Taraka fam.

Ol pikinini diwai na han frut o sayor, ol lain bilong siti kaunsil i salim nau i go long ol pipel bilong Atsera Maunten. Ol i laikim ol dispela pipel long groim bilong ol yet.

MOA

LONG MONI BILONG YU

Nupela!



TRAKA I WOKIM GUT OLGETA SAMTING

Vantaim 1166cc ensin,
Traka i gut tru long draivim
na em i gat strong long go antap
long ol maunten na long rot i nogat kolta.
Yu inap foldim ol sit sapos yu laik karim
kago long baksait.
Gutpela Toyota mechanical parts i givim gutpela wok.
Tasol bai yu mas kisim spares tu
sapos yu laikim.
TRAKA i wok tupela wei na i gutpela transport
bilong ologeta wantaim prais ino dia tumas.
Go lukim ol - Draivim ol nau long ELA MOTORS.



TOYOTA
TRAKA



ELA MOTORS

A Member of Burns Philp Group

YU ASK LONG EN. YU KEN KISIM

TOYOTA



Emily Taureka i wok long salim ol bis.



Keto Egi wok long Kapenta Kampani, Boroko.

Meri Wok Stuakipa

Nomei long ol kain kain wok ol meri save holim insait long PNG wanpela bikpela wok em wok stuakipa. Planti PNG meri i save holim dispela wok. Olsem Wantok ripota i go raun na toktok long sampela bilong ol dispela stuakipa.

Hia em ol sampela Keto Egi, wanpela toktok ol i bin mek- yangpela meri husat i im long wok bilong ol. wok long bikpela stua

bilong Kapentas i tok, 'Mi bin wok long dispela stua inap olsem 9-pela mun nau. Ol pipel husat i save kam insait long baim ol samting i save kam isi tasol na wet long lain. Tru long Fraide apinun na Sarere moning, mipela i save gat plan- ti kastoma na sampe- la bilong ol i save les long wet longpela taim long lain.'

Wanpela kastoma Eri Nason i tok, ol meri long Kapentas i wok wankain tasol olsem ol dispela husat i wok long ol arapela stua insait long Mosbi.

Emily Taureka i wok long wanpela stua we ol i save salim ol kain bilas olsem ring, na ol bilas bi- long hangamapim long nek na yau. Em i



tok planti kastoma bilong ol, em ol wait skin man na meri.

"Mi wok olsem wan- pela stuakipa inap olsem tupela yia, nau. Ol kastoma i orait. Tasol sampela bilong ol i save kros sapos oda bilong ol i no kamap gut. Sapos mipela i no mekim gut ol kain bilas bi- long ol, em ol i save kros long dispela. Planti bilong ol em long ol meri kastoma. Mi laikim dispela wok olsem stuakipa na ol pipel i orait. Em wan wan kastoma tasol i save givim hatpela taim long mi."

Klostu long dispela stua bilong Kapentas em wanpela arapela stua gen i stap. Dispe- la em i bilong B.P. Dispela stua tu i gat ol meri tasol i wok olsem ol stuakipa. Long hap bilong sal- im bia na ol strongpe- pela dring tu i gat wanpela meri i wok i stap. Nem bilong em, Walo Ila. Walo i tok, "Mi wok olsem wan- pela stuakipa inap 4-pela yia nau. Long dispela stua, mi wok inap moa long wanpe- la yia. Taim ol pipel i kam long baim dring long dispela hap ol i save kam isi. Tasol long Fonde apinun planti pipel i save hari- ap, long baim ol dring, long wanem em i las de bilong baim dring.

Anna Rongap

KUKIM GUTPELA KAIKAI

SELPIS NA KUMU

Samting yu mas i gat:

Ol kina bilong Mangro
Wanpela Kawawar
Kramap kru pamken
Kramap aibika
Wanpela kokonas
Sol.

We bilong wokim:

- Boilim ol kina
- Skrapim kokonas. Na boilim kumu inap 8 minit long wara nating.
- Taim sel kina i op, kisim mit na putim long pot wantaim kumu.
- Rausim wara nating ya na kapsaitim sup kokonas i go insait.
- Taim em i boil orait katkatim kawawar na putim insait tu.
- Nau kukim long paia i no hat tumas inap kumu i tan.
- Putim liklik sol na bihain sutim long plet rais na kaikai.



FANTA

TRADE MARK REGD

IT'S A
BOTTLE OF FUN



PREN BILONG YU
INAP OLTAIM



KANTRI BILONG YU LAIKIM YU

Brukim lo i sloim daun go het bilong kantri bilong yumi Papua New Guinea. Sapos yu laik istap long kantri usat i save behainim lo na igat bel isi olgeta taim bilong ol pikinini bilong yu long stap gut. JOINIM POLIS FOS NAU: P.N.G. i laikim halivim bilong yu long stopim brukim bilong lo na stopim ol bikpela rong. Sapos yu gat gutpela save na painim gutpela wok quiktam, Royal Papua New Guinea Constabulary i laikim ol man olsem yu.

- * Sapos yu gat form 4 save
- * Na igat wanpela ten nine krismas bilong yu o moa
- * Sanap 5 ft o moa
- * Redi long olim wok bilong halivim P.N.G.

- * Redi long trening long P.N.G. na autsait long P.N.G.
- * Nogat rekod long buk bilong polis
- * Redi long bihainim lo bilong ol polisman

Sapos yu laik joinim Polis Fos go long Polis Station klostu long yu na go toktok wantaim ol.

TINGIM! GO HET BILONG KATRI LONG BIHAIN TAIM ISTAP LONG HAN BILONG YU:

Oi Polis bilong kisim ol nupela man long Port Moresby bai kam long ples bilong yu long dispela taim.

KAVIENG MON 21ST APRIL — THURS 24TH APRIL
 MANUS MON 28TH APRIL —
 WEWAK TUES 29TH APRIL
 AITAPE WED 30TH APRIL — THURS 1ST MAY
 VANIMO FRI 2ND MAY
 MADANG MON 5TH MAY — WED 7TH MAY

MENDI FRI 9TH MAY
 HAGEN MON 12TH MAY — TUES 13TH MAY
 CHIMBU THURS 15TH MAY
 GOROKA MON 19TH MAY
 LAE WED 21ST MAY — THURS 22ND MAY

HOSKINS SAT 24TH MAY
 GURNEY TUES 27TH MAY
 PORT MORESBY WED 28TH MAY
 POPONDETTA THURS 29TH MAY
 — SAT 31ST MAY

HEB 374/W

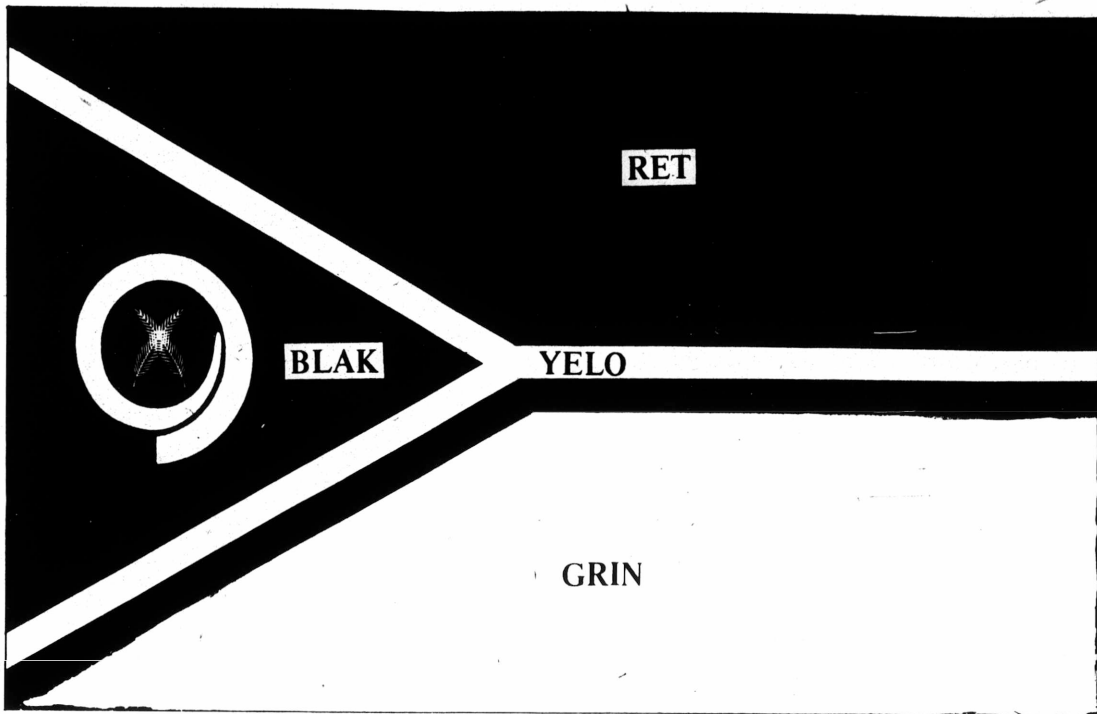

Wansolwara Kisim Plak

mat i makim ol meri usat i save wokim mat. Na bihain long dispela man i gat wanpela tit bilong pik. Dispela tit i soim ol kain samting i olsem mani long Niu Hebrides.

Na insait long tit bilong pik yu ken ukim tupela lip diwai. Em i soim ol pipel i gat pawa. Na tu ol liklik lip i stap long man bilong dispela tupela lip i soim olgeta ailan i stap long Niu Hebrides.

Plak

Plak bilong yumi i ret na blak long sait. Wanpela kumul i sindaun long wan sait na ol 5-pela sta bilong Sauten Kros i stap long hap sait. Long plak bilong Niu Hebrides, wanpela lain i katim long namel na i gat tripela sait.

Long sait antap,

kala i ret. Red kala i makim ol i wanpela pipel, wanpela kantri. Long ol seremoni bi long ol, ol pipel i save kilim pik na larim blut i kam ausait. Ret i soim rispek long ol bikman tu.

Long lephan sait kala i blak na em i makim graun. Blak i toktok tu long tumbuna pasin bilong Niu Hebrides. Tit bilong pik na tupela lip diwai tu i stap long dispela sait.

Long sait daunbil, kala i grin. Grin i makim ol 80 ailan bilong Niu Hebrides. Lain ya, em i katim plak i go tripela hap, kala bilong em i yelo. Yelo i makim lait em ol misin i karim i kam long dispela kantri.

Bikpela as tok bilong Niu Hebrides em: "Long God yumi sanap." Dispela tok-



tok ol i raitim long tok pisin bilong ol yet. Tok pisin bilong ol i wankain olsem bilong yumi. Nem bilong tok pisin bilong ol em Bislama.

Ren Kasanda



Mak bilong Niu Hebrides

DEVISE: "Long God yumi stanap"

Niu Hebrides em i wanpela ailan long Pasifik. I lupela bikpela kantri, Ingran na Frans i lukautim wantaim. Long mun Julai, Niu Hebrides bai kisim Independens. Vanu'aku em i wanpela bikpela politikal pati, i winim pinis ileksen. Lida bilong dispela pati, Pater Walter Lini, i stap nau olsem Sif Minista bilong ol. Long redi tru long Independens, Gavman bilong Niu Hebrides i kamapim pinis nesenal plak na mak gavman bilong ol.

Papua Niugini tu mekim wankain bipo long taim yumi kisim independens. Wanpela skul meri long Yul Ailan long Sentral Provins, i wok plak

bilong yumi na em i winim prais. Mista Kalaontas Malon i winim dispela resis long kamapim plak bilong Niu Hebrides. Mista Rick Fraser i

winim resis long kamapim sain o mak bilong gavman.

Sain bilong gavman bilong yumi i soim kumul i holim ol spia

na kundu. Sam bilong gavman bilong Niu Hebrides i soim wanpela man i sanap long wanpela ailan. Em i bilas long pasin tumbuna na em i holim wanpela spia. Dispela man i makim olgeta man bilong Niu Hebrides.

Na aninit long ailan i gat mat. Dispela

TRY YOUR LUCK

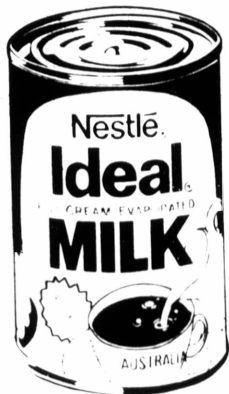

HURRY

BUY NESCAFÉ OR IDEAL MILK NOW AND TRY TO WIN ONE OF THE RADIO CASSETTES THAT ARE BEING GIVEN BY NESTLÉ



GOOD LUCK
from

WRITE YOUR NAME AND ADDRESS ON THE BACK OF A NESCAFÉ OR IDEAL MILK PAPER LABEL. PUT IT IN AN ENVELOPE AND ADDRESS IT TO:-

NESTLÉ,
P.O. BOX 1359,
BOROKO,
PORT
MORESBY



KEEP ON TRYING
This week's winner is
AINOKUN
of MINJ W.H.P.
There's 3 more
RADIO CASSETTES
TO BE WON

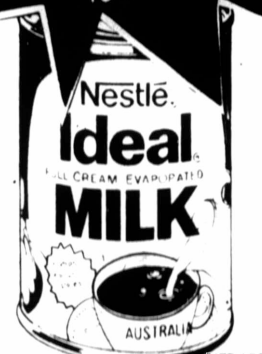

HEB 152

NESCAFÉ AND Ideal MILK

KAS BILONG YUT

Planti pipel i bin komplek pinis olsem Gavman bilong Somare i helpim ol yut long kamapim moa raskal pasin. Ol i mekim dispela toktok taim Gavman i givim ol yut ol kain samting olsem ka, bot na arapela samting. Dispela samting Gavman i bin givim long ol yut long kirapim bisnis bilong ol yet aninit long wanpela progrom ol i kolim Eben Erias Ektiviti Skim.

Wantok i raun i go kisim stori bilong tupela grup insait long Mosbi. Ol i sekap long wok ol i mekim wanem wok tru bihain long taim ol i kisim helpim long Eben Erias Ektiviti Skim. Nem bilong tupela grup em Kilakila Yut Grup na Lwanga Yut Senta.

KILAKILA YUT GRUP

Sapos yu raun klos long Taurama Bareks long Mosbi na

yu lukim ol lam i lait long solwara yu no ken tingting pret olsem Masalai bilong solwara i stap. Nogat. Em i wanpela lain bilong Kila Kila Yut Developmen Senta. Ol

i wok long tromoi umben long solwara. Olsem bai long moning ol i ken pulim i kam antap na kisim ol pis.

Kila Kila Yut i kirapim wanpela bisnis. Namba wan bisnis bilong ol em long lukautim kakaruk. Narapela bisnis em bilong kisim pis long solwara na salim long maket.

Mista Babani Onno i go pas long pait hat na kisim helpim long Eben Erias Ektiviti Skim. Em i Siaman bilong dispela grup, na em i stiaim ol manki long wok bisnis. Mista Babani i tok em sori tru long planti yangpela manki long Kila Kila Viles. Ol i stap nating long

ples bihain long taim ol i pinisim skul na i no inap painim wok. Em yet i bilong Kila Kila Viles. Olsem em kirapim long kisim helpim long UEAS olsem bai em i ken bungim ol skul liva na kirapim bisnis. Olsem ol i no ken paul nabaut long ples.

Long mun Oktoba 1979 ol i kirapim pinis wanpela bisnis. Eben Erias Ektiviti Skim i givim helpim long ol long kirapim dispela samting. Ol samting i kos K9,400. Ol i kisim wanpela trak, autobot mota, wanpela bot, bokis ais, umben, kersin lam, kapa, timba, nil bilong wokim haus, pik, spet, kaikai bilong kakaruk na arapela samting tu.

Bisnis bilong kakaruk em i win moa. Ol i winim pinis moa long K2,000 (2 tausen kina) long namba wan lain kakaruk ol i salim pinis long maket. Ol i salim 990 kakaruk olgeta long K3,000. Ples bilong lukautim kakaruk i stap long hap graun bilong ol yet long rot i go long Taurama Ami Bareks.

Samting olsem 26 boi i wok long dispela wok long lukautim kakaruk. Ol i save wok long sift. Sikispela boi i stat wok long 8 klok moning long lukautim ol kakaruk i go inap 4 klok. Long 4 klok arapela lain boi i kam na kisim ples. Ol i wok inap 12 klok long biknait.

Narapela lain i kisim ples bilong ol long 12 klok nait i go inap 8 klok long moning. Ol i lukautim ol liklik kakaruk inap ol i bikpela na redi long ol i ken salim long maket long man i ken baim na kaikai.

Ol boi i save givim kaikai na wara long ol. Long nait ol i laitim ol lam bai ol kakaruk i no pilim kol. Nau ol i lukautim ol kakaruk bilong mit tasol. Ol i no go insait yet long lukautim kakaruk long karim kiau. Mista

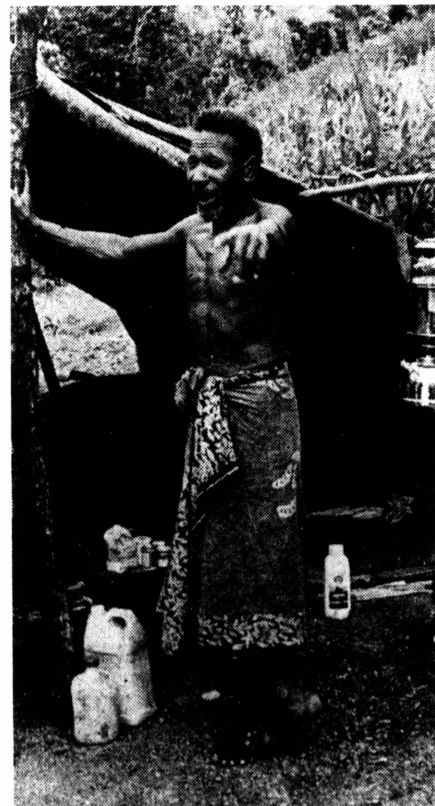

Onno i save baim ol boi long samting olsem K1 long ol wan wan sift ol i wokim long olgeta wik. Ol i save salim kakaruk long maket taim kris-mas bilong ol i 2 mun.

Ol salim kakaruk long Boroko na Koki maket. Ol boi i mekim stail na raitim wanpela hap sain long tok Inglis na tok "The Cheapest live chicken you'll ever find". KAM baim long hia. Ol i no dia.

Wok bilong painim pis i hat liklik long ol boi. Ol i no save yet long tromoi umben long gutpela hap ples we i gat moa pis i stap. Olsem na i gat wanpela lapun man nem bilong em Jim Babane i stap wantaim ol. Em i wok long skulim ol boi long go aut long solwara long painim pis. Em i soim ol long gutpela ples long tromoi umben.

I gat 12-pela boi olgeta i wok long go aut painim pis. Ol i bikpela boi tasol. Ol boi i wokim wanpela kem na ol i save slip long dispela hap. Olgeta nait ol i save go aut long solwara na tromoi umben. Na long moning ol i go aut gen na pulim umben i kam antap painim pis.

Sampela gutpela taim ol i save painim planti pis, sampela taim ol i lus. Mista Onno i tok, planti boi i les taim ol i stap long kem olsem na em i mekim ol wok sift tu.

Olgeta pis ol i painim ol i save karim i kam long Kila Kila Viles. Na ol i save salim long ol pipel. Ol i no sasim ol pipel long bikpela mani. Tasol, ol i save wokim sam-

ting olsem K50 long ol pis taim ol i salim long maket. Taim ol i salim long ples ol i no kisim bikpela mani. Yu save wantok sistem i stap. Mista Onno i tok em i wok long painim we olsem bai em wantaim ol boi i ken salim gut ol pis na kisim moa mani.

Ol i tingting tu long painim moa mani long baim wanpela strongpela kanu bilong ples olsem bai kanu i helpim narapela bot ol i gat long pulim pis i kam antap.

LWANGA YUT

Namba tu grup yumi lukim pinis em long Lwanga Yut Developmen Senta. Dispela senta i bilong ol manki husat i pinisim skul pinis long gret 6 na ol i go long dispela senta long kisim moa save long samap, kapenta, wok gaden, dro na arapela samting olsem.

Lwanga Yut Developmen Senta i no bisnis. Em i olsem wanpela skul. Dispela skul em bilong ol skul liva tasol. Ol sista bilong katolik sios i ranim dispela skul.

Long las yia ol sista i aplai long Eben Erias Ektiviti Skim. Na ol i givim ol K30,000 (30 tausen kina). Ol i baim ol masin bilong samap, ol buk, tenis bol, tul bilong kapenta na wok gaden, na sampe-la sia. Sista Bernadete, husat i bosim dispela senta i tok dispela samting ol i givim i helpim ol tru.

Dispela UEAS i helpim ol tu long wokim wanpela klasrum na tu ol i putim wanpela masin bilong hatim wara i antap long dispela klas-

rum. Ol i wokim tu wanpela basketbal kot bilong ol.

Long dispela senta ol i lainim ol sumatin meri long samap, kuk, wokim gaden na planim ol samting. Ol sumatin man i lain long wok kapenta, wok gaden, na tu ol i lain long namba, saiens, na tok Inglis.

Tupela sumatin bilong ol i go pinis long kisim moa save long dro. Wanpela i go long Goroka Teknikal Koles. Na arapela i go long Nesenal Ats Skul. Tupela i lain moa long droim ol kain kain piksa. Bi-hain long pinisim wanpela via long dispela senta ol sumatin i go insait long ol

vokesenal skul. Lwanga Yut Developmen Senta na Kila Kila Yut Developmen Grup i salim bikpela tenkyu i go long Eben Erias Ektiviti Skim long dispela helpim ol i givim long ol.

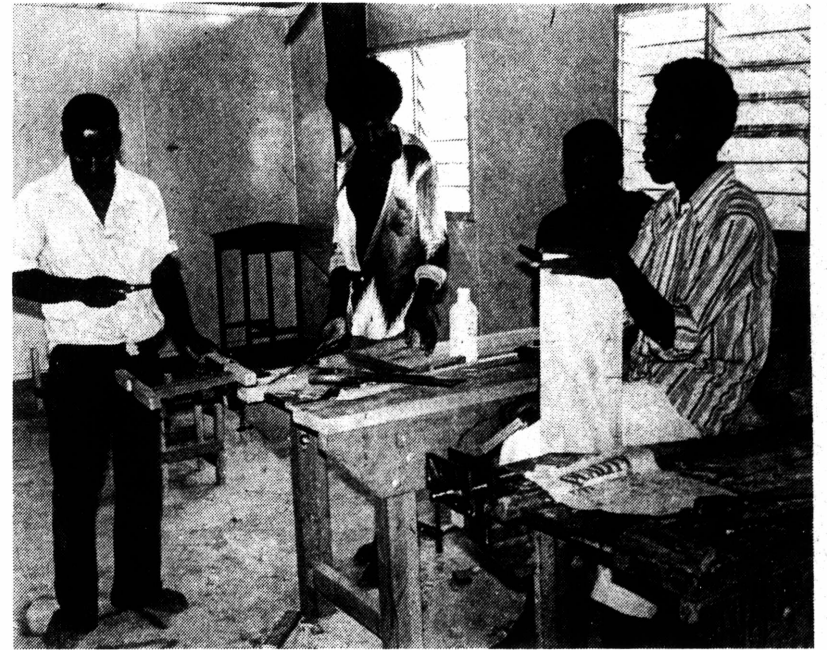

SUMITOMO

Askim mipela long strongpela taia tru

Lankrusa Dyna na Stout Taia

SL 803

DUNLOP
Aircorps Rd, Lae
42-1322

AUSTRALIA, INAP TRU LONG OLKAIN SAMTING YU LAIKIM.

AUSTRALIA, INAP TRU LONG OLKAIN SAMTING YU LUKIM.

PLANTI GUTPELA SAMTING LONG ISI PRAIS. NA OL I STAP KLOSTU TASOL.

ASKIM SAVEMAN BILONG AUSTRALIA.

Dispela saveman inap tokim yu we yu ken baim ol samting long Australia. Na em tu inap skulim ol PNG bisnisman we ol i ken salim samting bilong ol long Australia. Sapos yu laik em helpim yu, rait tasol i go long:
The Australian Trade Commissioner
P.O. Box 9129,
Hoboka. PNG.

Askim Tasol Australia Tret Komisina.

Nupela Spot Buk

K2.99
Tasol

Yu laik ritim ol stori bilong ragbi-soka-boksing? Yu laik lukim ol PNG spotman?

Baim Nau



Baim long stua o salim K2.99 long Wantok, PO Box 1982, Boroko.

Mi putim K2.99 pinis. Salim buk i kam long:

Nem:

Ples:

P.O. Box:

Provins:

No ken salim mani. Salim postal oda o sek.

Skul Bilong Ol Loya

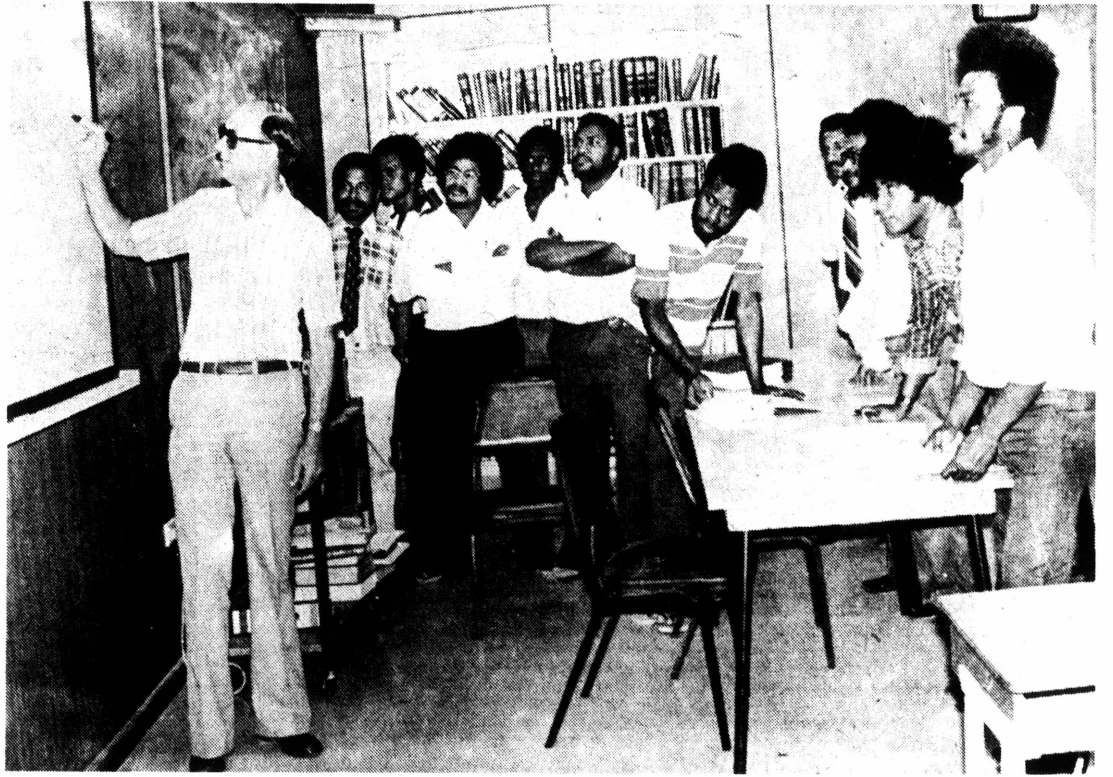

Ol treni loya sanap harim skul. Dairekta bilong ol em. Mista Keith Young. Kirap. long lephan: Keith Young, Malinu Yagi, James Solo, Ure Hane, Meksen Darius, Moses Miva, Ignatius Matus, Alphonse Wohiningu, John Kabeuya, Andrew Norrie, Zacchary Gelu.

Taim yu kisim digri long Lo long Yunivesiti, bihain yu skul long em long 4-pela yia pinis, dispela i no min olsem yu ken go aut na harim kot hariap tru. Digri i no min olsem yu save pinis long olgeta samting yu mas mekim olsem wanpela loya. Em i no helpim yu tumas long harim kot o helpim wanem man o kampani i sanap long ai bilong kot.

Yu laik kamap wanpela loya tru? Pas-taim yu mas lain long we kot i save ran na we bilong yu mekim toktok. Yu mas lain long we bilong painim lo insait long lo buk long sapatim toktok yu mekim na we bilong bilas. Yu mas lain tu long olkain lo bilong kantri o kampani. Insait long liklik o bikipela kot wok bilong loya i mas smat moa. Olgeta toktok em loya i mekim long helpim man i sanap

long kot o i laik kot-wanem man orait em mas putim gut toktok na soim bik jas olsem dispela man i brukim lo o em i no brukim lo. Olsem tasol i gat wanpela skul long helpim ol loya husat i kisim digri pinis long Yunivesiti. Ol i kolim dispela skul, "Ligal Trening Instityut" o skul bilong ol loya. Ligal Trening Instityut i stap long Gordons insait long Mosbi. Dis-

pela skul i bilong givim ol trening long kamap loya. I gat 30 man i stap trening long dispela skul na ol i tren long 1 yia olgeta. Bihain long wanpela yia trening, ol i go aut wok aninit long wanpela loya long Jastis Dipatmen o kampani husat i wok pinis long planti yia. Ol i wok aninit long lukaut bilong em long 6-pela mun olgeta. Bihain long 6-pela

mun i pinis orait, dispela loya yet i ken tok olsem dispela man i redi long wok em yet olsem loya long bik kot na ol lokal na distrik kot. Em nau ol i makim em olsem wanpela loya tru. Sapos long dispela 6-pela mun ol i lukim olsem, em i no wokim gut wok bilong loya orait em i no go insait long bik kot olsem wanpela loya. ● Ben Kasanda



Poto hia i soim wanpela man bilong nambis long hap bilong Bogia long Madang Provins. Kanu bilong ol pipel long dispela hap i luk olsem na i gat saman. Man hia i lukluk i go long Manam Ailan. Manam Ailan oltaim i gat smok na klaut i kamaut long het bilong em.



Maski Kros Long Wantok

taim na mi save lukim im ol pas i no save givim gutpela helpim long ol brata susa bilong yumi em ol i stap insait long PNG.

nuspepa bilong kros i go long narapela brata bilong yu, o kain tok bilong skrapim bai i belhat? Nogat. I gutpela pasin, sapos yu autim sampela gutpela aidia bilong yu long helpim sampela ol tarangu man meri ol i sot long tingting o ol i gat wari long sampela samting. So em liklik tingting bilong mi. Bikos mipela sampela i ritim helpim long yu husat

kristen man meri insait long kantri long givim sampela gutpela tingting o save long helpim gutpela sindaun bilong yumi. Mi yet mi pilim na yu husat i pilim tu ol kain pasin bilong kros i no inap helpim yumi na kantri.

kantri PNG bambai yumi olgeta sindaun sekhan.

Paul Areng, C.M.Mai, Kimbe, WNB.P.



Ol brata na susa bilong PNG mi ritim helpim bilong yupela. Mi no laikim pasin bilong tok kros na tok pait. Helpim mi, na

Dia Edita — Plis, givim liklik spes pastaim long mi na bai mi putim liklik wari bilong mi i go insait long Wantok Niuspepa.

Plantil ol pas mi ritim mi save lukim sampela brata susa i givim tok hat o tok bilas o toktok bilong skrapim bel bilong ol narapela man meri bai i hat moa moa yet.

Wari bilong mi i go olsem: Mi save ritim ol pas long planti

Ating mi ken tok olsem, Wantok i no

Senisim Yunipom Bilong Sekyuriti

Dia Edita — Inap yupela givim mi hap spes long mi na mi autim liklik wari bilong mi?

mi laikim wok bilong ol na yunipom bilong ol.

Su na sokis em bilong ol plisman bilong yumi long PNG.

Orait? Na yupela mas painim narapela kain Yunipom na putim. Em tasol liklik wari bilong mi na husat man o meri i laik sapotim mi, yu mas rait i kam long Wantok Niuspepa bai mi ritim. Em tasol tenk-

yu.

Michael Mendokane, Tupo Patage, Enga Provincs.

Liklik wari bilong mi i go olsem. Mi laikim Sekyuriti gat long Mosbi siti na tu

Tasol wanpela Sekyuriti sevis, Debesa ya em mi no laikim long wanem ol i no plisman na putim Yunipom bilong Plis.

Debessa sekyuriti sevis em yu wanpela kampani maski pilai pilai long yunipom bilong gavman taim yu ritim dispela pas.

Bos Paulim Gavman Ka

Dia Edita — Mi laik bai yu givim mi liklik spes long mi bai mi putim wari bilong mi long Wantok Niuspepa. Wari bilong mi i go olsem.

ol bos i no save wokim wanpela wok bilong Gavman long wiken o Sarere na Sande. Ol i save yusim dispela ka long karim famili bilong ol na wantok bilong ol tasol.

bos i save wokim dispela pasin long bekim sampela kwesten:-

Mi save lukim ol bos bilong wan wan dipatmen long Maprik i save paulim ol gavman ka. Ol dispela ol bos i save yusim ol gavman ka olsem ol praivet ka bilong ol o ka ol i baim long mani bilong ol yet.

Dispela kain pasin yupela ol bos i save mekim em yupela i save westim bensin bilong gavman tasol. Sapos yupela i no yusim ka long ol dispela ol samting bai ka i no inap bagarap kwik.

1. Yupela i save baim bensin long mani bilong yupela yet o nogat?
2. Bensin bai i kamap nating o gavman i save lusim bikpela mani long dispela.
3. Ka yupela baim long mani bilong yupela o em i ka bilong gavman long mekim wok bilong gavman.

Na tu ol i save yusim gavman ka olsem famili ka. Ol dispela

Mi laikim yupela ol

Ralph Ningidu, Is Sepik Provincs.

Laikim Somare

Dia Edita — Yes, mi amamas tru, yupela na mipela i mas sapot tru na Mista Somare i mas kisim bek wok gavman.

pinis olsem, em i gavman tru bilong PNG.

Mipela planti pipel bilong Morobe Provincs, i laikim Mista Somare i kamap gavman gen nau. Em tasol tok bilong mi.

Yumi mas luk save gut stat long 1972 i kam inap 1979. Mipela harim planti wok em i save mekim long PNG na ovasis. Mipela i harim na amamas long Mista Somare. Em i gat pawa long wok gavman.

J. John Sammy, Finschafen, Morobe Provincs.

Mista Somare i givim Selp Gavman na Independens long PNG. Na yumi save

Salim ol pas i kam long:
WANTOK
BOX 1982
BOROKO

Aitape Plis i No Longlong

Dia Edita — Inap yu givim mi liklik spes long bekim pas bilong brata ya, Paul W. Yai bilong Aitape, WSP.

Mi ken tokim yu stret nau. Aitape, em i no ples bilong trabel. Sapos yu laik, orait, kisim sip o balus na go raun lukim olgeta bikpela taun. Yu mas go long Mosbi, na Lae, na Rabaul, na Goroka, na Madang na bai yu lukim kain wok ol plis i save mekim. Mi tokim yu stret, yu manki wara tasol. Sapos ol plis i no mekim wok, bai yu stap olsem nau o nogat? Plis fos na arapela disiplin fos, ol i bun bilong kantri.

Yes brata, yu tok olsem, ol plisman long Aitape i no save gut long wok bilong ol. Ol i no save mekim gut wok bilong ol. Brata, ating i luk olsem, yu no save gut long wok mipela ol plisman i save mekim.

Long pas bilong yu, yu tok olsem, ol plisman long Aitape i no save kotim man taim ol kaunsil i kisim man i go long opis. Em long ol rong olsem spitim motobaik o ka o spido bilong ka i bagarap. Olsem na ol kaunsila i save kisim ol i kam long kotim ol.

Plis i stap mekim wok na olgeta samting i stap orait tasol. Ating mi no save, yu bilong Aitape stret o yu bilong bikbus. Yu mas tingting gut pastaim. Yu mas save olsem, Aitape, em i no gat nem nogut i kamap olsem ol arapela hap bilong kantri. Em i wanpela gutpela liklik taun yet. Nogut yu giaman na tok ol trabel i save kamap long Aitape.

Tasol brata, ating yu no gat liklik kru long het bilong yu. Yu mas save gut long wok bilong ol plis, orait, yu ken raitim pas long Wantok Niuspepa bilong pablik long lukim.

Em tasol. Sapos tok bilong mi i no stret long tingting bilong yu, orait, rait tasol i kam long Wantok Niuspepa na bai mi ken lukim.

Na tu yu tok olsem, ol pipel bilong Aitape i longlong pinis long ol plis. Yu min wanem long dispela tok tok bilong yu. Ating yu min olsem ol plisman long Aitape i no mekim gut wok bilong ol, a?

Tony R. Ranaipe, Madang Provincs.

Pinisim Somare Gavman

Dia Edita — Inap yu givim spes long mi, bai mi bekim pas bilong K. Seto bilong Mt. Hagen W.H.P.

i no inap long ranim kantri gut bai yu tingting long poket mani tasol na yu no inap long tingting long ol pipel na kantri bilong yu. I luk olsem yu laik bai kantri mas go het hariap a! Man sapos yu laik hariap long go het bilong kantri bilong yu, nating bai kantri ran kranki tru.

Yes brata mi bin lukim pas bilong yu long 21 Mas 1980 na mi no amamas tumas. Yu bin toktok olsem, gutpela, ol i pinisim Gavman bilong Somare.

Pren, mi laik tokim yu olsem, i tru Misis Rooney i gat rong liklik na i go kalabus tasol Somare i rausim em bek. Na mi laik tokim yu olsem, em i laik bilong Somare. Sapos em i laik givim em sens long wok bilong em, em i orait. Bikos em i Gavman, em i ken lukim wanem samting i stret na wanem i no stret.

Em tasol liklik bekim bilong mi, yu husat laik bekim, em orait tasol. Tenkyu.

Michaela S.D., Alexishafen, Madang.

Mi tokim yu sapos yu yet, yu sanap long Gavman nating bai yu



PINE-O-CLEEN

Rausim ol jerm long haus bilong yu

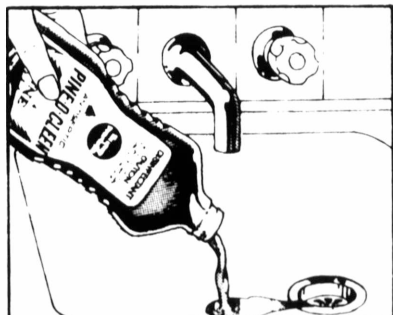

Jerm i save kamap long olgeta hap. As plis tru bilong em raus kuk.

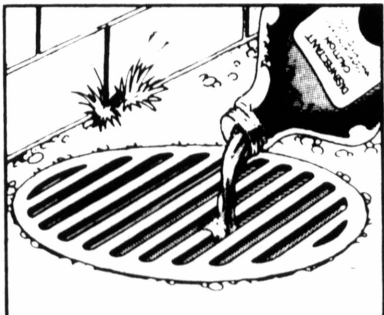

Ol bare na hul inap kamapim sik. Kapsatim liklik Pine o Klin bai yu mekim save long ol jerm.

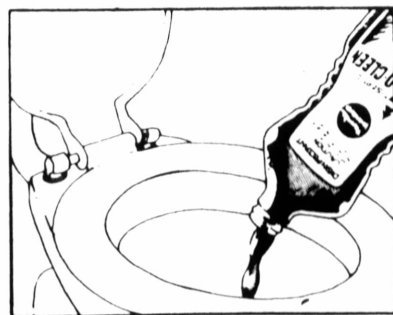

Ol toilet na yu ken klous long Pine o Klin. Kapsatim liklik long toilet na toilet stap.



Jerm i stap long olgeta ples doti. Klousim haus long Pine o Klin. Klousim plus long haus kuk na toilet long Pine o Klin. Putim Pine o Klin long baket wara na klousim plus Pine o Klin i save klous indar ol kain kain jerm long haus.



Yu ken kisim long olgeta bikpela stua na tred stua

KAUNSI LA TRAIM



PABLIK NOTIS

ILEKTORAL KOMISIN BILONG PAPUA NIUGINI.

OL PROVINSAL GAVMAN ILEKSEN.

Em hia tok save i go long pablik long taim ol Provinsal Gavman Ilekseen bai kamap.

ENGA PROVINS

Ol nominesen i pas pinis.
Ol de bilong vot, 3-5-80 - 24-5-80.

MOROBIE PROVINS.

Ol nominesen i pas pinis.
Ol de bilong vot, 17-5-80 - 7-6-80.

NOT SOLOMONS PROVINS

SIMBU PROVINS.

SAUTEN HAILANS PROVINS.

WESTEN HAILANS PROVINS.

WEST NIU BRITEN PROVINS.

Ol nominesen bai pas long 30-5-80.
Ol de bilong vot, 31-5-80 - 21-6-80.

N.G. McNAMARA.

Namba tu Komisina bilong bosim ol ilekseen.

Mi raitim dispela long de 16 mun Epril, 1980.

Ol Wes Irian Kisim Sevis Mani

Long Jayapura, long namba 15 de bilong mun Mas, olgeta sevis plisman i kisim sevis mani bilong ol. Em, ol plisman i wok long taim Das (Dutch) gavman i stap long 1910 i go inap long 1962. Long 1962, Das i lusim Irian Jaya. Ol i lusim Irian Jaya long han bilong Indonesia long lukautim.

Wanpela bikpela kibung i bin kamap long Jayapura long Mas 15, 1980. Long dispela kibung, komanda bilong plis long Jayapura, Lt Kenel Anang Suripto i tok, olgeta mani bilong ol sevis plisman i stap yet. Em i tok, dispela mani i bin kam long gavman bilong Das. Na dispela mani, em i bilong baim ol plisman i bin wok wantaim ol Das long taim bipo. Lt Kenel Suripto i tok, gavman bilong Indonesia i no inap paulim dispela mani. Ol bai givim i go stret long

wanem ol pipel i wok olsem plisman long taim bilong ol Das. Em i sevis mani bilong ol dispela sevis plisman.

Plis Komanda i tok, ol lokal pipel i laki tru long kisim dispela kain mani. Tasol, ol i mas mekim ol gutpela samting wantaim dispela mani. Ol i mas wokim gutpela haus, o baim gutpela klos samting o mekim wanpela gutpela wok. Ol lokal pipel i no kening long yusim mani long spak, spak tasol.

Taim kibung i pinis,



Ol sevis plis kisim mani ol Das i salim pinis long ol. Ol i kisim long Jayapura.

ol sevis plisman i go long opis bilong ol plis long Jayapura na kisim mani bilong ol. Planti bilong ol i kisim K1,000. Sampela i kisim K600 na sampela arapela i kisim K200.

Lt Kenel Suripto i tok, sampela bilong ol dispela sevis plisman i ranawe i go pinis long PNG. Tasol,

mani bilong ol bai stap wetim ol. Long PNG i gat tupela man i stap. Welem Rumbiak, em i stap

long Mosbi. Na Thitus Meho, em i stap long Manus. Mani bilong tupela bai stap wetim tupela.

KISIM TELIPON

Daru insait long Westen Provins na Lorengau insait long Manus provins bai kisim gutpela STD telipon sevis. Wok bilong putim telipon bai kos 2

milien 7 handet tausien kina olgeta (2,700,000). Ol bai wokim tu wanpela haus bilong telipon long Bialla na Kimbe.



MOTO HAIA KA LO BILONG 1956

EPLIKESAN BILONG KISIM SETIFIKET BILONG REJISTAIM TAKSI LONG MADANG TAUN.

Madang Provinsal Gavman, long strong bilong pawa em i kisim long Moto Haia Ka lo bilong 1956 na long olgeta arapela pawa em i gat, em i laik welkamim husat ol pipel i laik kisim setifiket bilong rejistaim taksi bilong ol long Madang taun. Sapos yu laik rejistaim taksi bilong yu, em hia ol pasin yu mas mekim.

**TAUN: MADANG
HAMAS SETIFIKET BILONG REJISTRESEN: 7 (SEVEN)
OL SAMTING YU MAS I GAT NA OL PASIN YU MAS MEKIM**

1. Man i aplai long kisim setifiket i mas:-

- (a) i stap ranim taksi bisnis pinis o i laik stat nau, na i stap ranim praivet haia ka o i laik stat nau.
- (b) wanpela gutpela man i no save bikhet o hambak.
- (c) long tingting bilong mipela, dispela man i mas gutpela man bilong mekim dispela wok.
- (d) salim tok long Plis Komisina, (sapos mipela askim em) long ol samting mipela i toktok i stap long (a), (b) na (c).

2. Long eplikesen pepa bilong yu, yu mas:-

- (a) tokaut long wanem as tru na yu laik kisim setifiket bilong rejistaim taksi bilong yu.
- (b) tokaut long sapos yu stap ranim taksis bisnis o yu laik statim nau. O yu stap ranim praivet haia ka bisnis o yu laik statim nau.
- (c) tokaut long wanem we tru, dispela bisnis bilong yu inap kamapim winmani.
- (d) tokaut long wanem kain ka yu laik rejistaim.
- (e) sapos dispela bisnis i no bilong ol PNG man stret, plis tokaut long hamas mani ol PNG man i lusim long dispela bisnis. Na tokaut long namba bilong sea ol i kisim.

3. Sapos man i salim eplikesen na i no wokim stret eplikesen fom o sapos em i no wokim olsem mipela tokaut long en:-

- (i) Plis Komisina inap tok nogat long eplikesen bilong em.
- (ii) Na Madang Provinsal Gavman inap rausim eplikesen bilong em.

4. Sapos Plis Komisina i tok nogat long eplikesen bilong yu, mipela bai tok save long yu. Na tu yu ken askim mipela long lukluk gut gen long eplikesen pepa bilong yu.

5. Sapos yu kisim setifiket bilong rejistresen pinis, yu mas stat wok hariap. Sapos yu i no stat wok hariap, Plis Komisina bai rausim dispela setifiket bilong yu.

6. Yu mas raitim tupela eplikesen pepa. Long baksait bilong eplikesen, yu mas raitim olsem, "Eplikesen Bilong Pablik Haia Ka Laisens." Putim long skinpas na salim long dispela adres.

Executive Officer,
Madang Passenger Transport Licencing Committee,
Madang Provincial Government,
P.O. Box 2026,
YOMBA.
Madang Province.
Yu mas salim bipo long Me 9, 1980.

7. Ol eplikesen i no bihainim ol samting mipela raitim antap ya, bai mipela rausim.

Mi raitim dispela notis long Epril 8, 1980.

KAKI ANGI,

Provinsal Minista bilong Komes, Turisim na Kalsa.

Ston Karamapim Ol Man

Long wanpela de ol 11-pela brata i laik go long bus long painim abus. Olgeta brata i kisim akis, banara, spia na sampela kaukau. Na tu ol i kisim ol dok bilong ol long helpim ol painim abus.

Long dispela taim, san i hat tru. Na ren i no save pundaun. Long nait, man, mun i save lait gut tru.

Ol 10-pela brata i no kisim ol meri long go wantaim ol. Tasol wanpela brata, yes. Em i kirap na kisim meri bilong em long go wantaim ol. Na dispela meri bilong em i gat bel. Klostu taim, em bai karim pikinini.

Taim ol i wokabout nau, ol arapela brata ya i hariap tru long wokabout i go insait long bikbus. Tasol tupela marit ya, ol i isi tasol bihainim ol. Long wanem, dispela meri, em klostu karim pikinini. Olsem na em i no gat inap strong long go antap hariap hariap long ol maunten.

Ol arapela brata ya i go kamap pas long ples ol i laik slip long en. Na tupela marit i go kamap samting olsem 5 klok apinun. Olgeta i kirap na stretim ples bilong slip long nait.

Ol i stretim ples long wanpela bikpela ston. Dispela ston, em i olsem wanpela haus. Na em i gat bikpela spes insait long en we ol planti man i ken slip long en. Ol man bilong ples i save go slip long en taim ol i save go painim abus. Olsem na dispela nait tu ol brata ya i laik slip long dispela ston haus.

Olgeta brata wanpela meri i slip insait long dispela ston. Na long moning ol 10-pela brata i kirap na i go long painim abus. Na arapela brata bilong ol i stap long wokim liklik haus we meri bilong em i ken karim pikinini long en. Em i wokim pinis na em i tokim meri bilong em long slip i stap. Na em bai bihainim ol arapela brata ya long go painim abus.

Taim em i go pinis, meri bilong em i karim pikinini man. Em i slip i stap na em i lukim dispela bikpela ston i kam daun ka karamapim stret ples we ol man i save slip ya. Em i kam

daun i stap liklik na i go antap gen na stap stret olsem bipo.

Dispela meri i lukim olsem na em i pret nogut tru. Em i no moa givim susu long pikinini bilong em. Nogat. Em i slip i stap na i wok long lukluk tasol long ston ya.

Em i pret i stap na liklik taim bihain man bilong em na ol brata bilong em i kam. Ol i karim ol abus na lap amamas i kam.

Taim ol i kam bung wantaim, meri ya i tokim ol long wanem samting ston ya i bin mekim. Tasol ol man ya i bikmaus na tok, yu giaman. Olgeta taim mipela i save kam slip long dispela ston haus na painim abus. Olsem wanem na yu giamanim mipela olsem, dispela ston i bin surik. Ating yu laik mauswara long mipela, ah?

Meri ya i kirap na i tokim ol, mi no giamanim yupela. Tru antap, mi tok. Mi bin lukim stret long ai bilong mi. Olsem na yupela i no ken go slip long dispela ston haus.

Ol 10-pela brata i strong tumas na daunim tok bilong meri. Meri i les long ol na i tok, em i orait. Yupela i tok strong tumas. Yupela i ken go slip tasol man bilong mi bai kam slip wantaim mitupela pikinini.

Man bilong meri ya i bilipim tok bilong em. Olsem na em i karim meri na pikinini bilong em slip long liklik haus. Ol arapela brata ya i sakim tok. Olsem na ol i go slip insait long ston haus.

Na long biknait tru, dispela ston i surik kam daun na karamapim olgeta brata. Taim ston i kam daun na pas olgeta, em i pairap olsem bikpela gan.

Ol man insait i kirap nogut tru na stat ran nabaut. Ol i painim dua long go outsait. Tasol ol i no gat we long go outsait.

Ol i stat bikmaus na traim surikim ston nabaut bilong painim dua. Ol i wok na hatim kraik na singaut tu. Ol i ting ol man bai harim ol na ol bai kam rausim ston.

Tupela marit i harim

pairap na bihain tupela i harim kraik bilong ol. Tupela i lukluk i go na lukim ston i kam daun na pas pinis. Ol i no wet moa. Ol i kisim samting na hariap tru long go long ples na painim helpim.

Tupela i taitim rot i go na tulait painim tupela long ples stret. Ol i go kamap na tokim ol man bilong ples.

Em nau na olgeta man bilong ples i kisim akis bilong ol na ran i go olgeta long dispela hap. Ol i go kamap na harim kraik na bikmaus bilong ol 10-pela brata ya. Ol brata ya i singaut long ol man ya long rausim ston.

Ol man long ples i katim wan wan diwai na traim sakim ston. Ol taitim bun i go i go tasol ston i no surik liklik.

Ol i stap liklik na harim ol brata i kraik na bikmaus strong i tok, wanpela brata i dai pinis na 9-pela tasol i stap.

Ol man tu i kraik raun raun stap autsait long ston. Ol i stap liklik na harim olsem namba tu brata i dai. Na 8-pela tasol i stap.

Na tri brata i dai pinis namba 4 i go las long ol tasol i stap. Em singaut na i tok, mi wanpela tasol i stap nau. Olgeta brata i dai pinis. Em i stap liklik na singaut i tok, gudbai long yupela olgeta. Ating mi tu bai lus nau.



I go na ol man i no harim em gen na ol i save olsem, em i dai pinis. Man, ol i pundaun stap long graun na hatim kraik. Ol i save, ol bai i no inap lukim pes bilong ol moa.

Ol i kraik i go i go na ol i tok long go bek long ples. Olsem na ol i kirap isi, tasol na kraik kraik i go long ples. Ol i wari nogut tru.

Ol i go bek slip wari long ples i stap. Long moning ol i bungim kaikai na karim i go wokim pati arere long dispela ston. Meri bilong ol man i dai ya, i wari. Olsem na ol i no kaikai gut. Ol i pati pinis nau, na ol i go bek long ples.

Dispela ston i stap yet. Na nem mipela i save kolim dispela ples, em, "10-ples!" Nem tru, em i, "Tumon". Mipela i save kolim "10-ples" makim stori bilong ol 10-pela man i dai ya.

Em tasol, stori tumbuna bilong mi.

Nason Bob Du.
Kudjip, WHP.



King I Kam Bek

2 Samyuel 18 - 24; 1 King 1:1-9

NA TUPELA LAIN AMI I BUNG LONG PAIT LONG BIKBUS BILONG IFREM: AMI BILONG DEVIT I PAIT STRONG MOA, NA OL SOLDIA BILONG ABSALOM I PRET NOGUT TRU NA PAIT KRANKI NA OL I RANAWA NABAUT.



OL AMI BILONG ABSALOM I LUS LONG PAIT NA ABSALOM I PRET TRU. EM I TING SAPOS OL I HOLIMPAS EM BAI OL I KILIM EM I DAI, LONG WANEM, EM I BIN MEKIM NOGUT LONG KING BILONG EN. OLSEM NA EM I TRAIM LONG RANAWA LONG HOS.

EM I RANAWA I GO, TASOL LONG ROT GRAS BILONG HET I PAS LONG HAN BILONG DIWAI NA EM I HANGAMAP I STAP.



ABSALOM I LAIK RAUSIM DEVIT NA KAMAP KING, OLSEM NA LONG BUS BILONG IFREM BIKPELA PAIT NOGUT TRU I KIRAP. ABSALOM I LUKIM DEVIT I LAIK WINIM EM NA EM I RANAWA I GO, TASOL DIWAI I PASIM EM.

JOAP YU KAM LUKIM. ABSALOM I PAS LONG DIWAI LONG HAP I GO.



TRU A? BILONG WANEM YU NO KILIM EM KWIK?

Komik hia i kamap pinis long buk. Yu inap baim long olgeta Kristen Buk Stua.

Waso Menesa Go Pinis

Bihain taim bilong Waso kampani bai go gut sapos nupela menesa na ol dairekta i tingting na wok gut long ranim kampani.

Dispela toktok i kam long olpela menesa bilong Waso, Mista Myron Herman. Em i lusim kampani na go bek pinis wantaim famili bilong em long Amerika long Epril 10. Ol i no makim nupela menesa yet. Waso em i wanpela bikpela kampani em ol pipel bilong Enga Provins yet i ranim. Kampani i stap long Wapenamanda.

Waso i gat ol stua i save salim olkain samting, na wanpela woksop long fiksima ka. Na tu ol i gat bisnis bilong baim kopi, sayor na kumu long ol pipel, na salim long ol bikpela kampani olsem ANGCO, Kopi Intenesenal na Fud Maketing Koporesen (kampani bilong salim ol kaikai). Waso i gat 500 man meri bilong Enga Provins yet i holim sea insait long en. Luteran Gut Nius Sios na Wapenamanda Lokal Gavman Kaunsil i holim tu sampela sea insait long Waso.

Samting olsem 150 man meri bilong Enga Provins yet i wok insait long Waso. Waso kampani i wanpela han opis tu bilong lukautim Pos Opis, beng na opis bilong bukim tiket bilong Air Niugini na arapela balus kampani. Mista Herman i tok, em i kamap menesa long yia 1978 long taim, Waso kampani i wok long stretim olkain wari insait long kampani.

Dispela long wanem kampani i sot long mani long mekim wok bilong em. "Taim mi stap olsem menesa stat long yia 1978 i kam inap long dispela yia mipela wok hat moa long stretim ran bilong kampani olsem bai kampani wokim liklik winmani" em i tok.

Mista Herman i kam wantaim famili bilong em long PNG long yia 1968. Na em i wok olsem advaisa bilong agrikalsa o wok didiman wantaim Gut Nius Luteran Sios. Insait long dispela 12-pela yia em i tisa tu long Pausa Hai Skul.

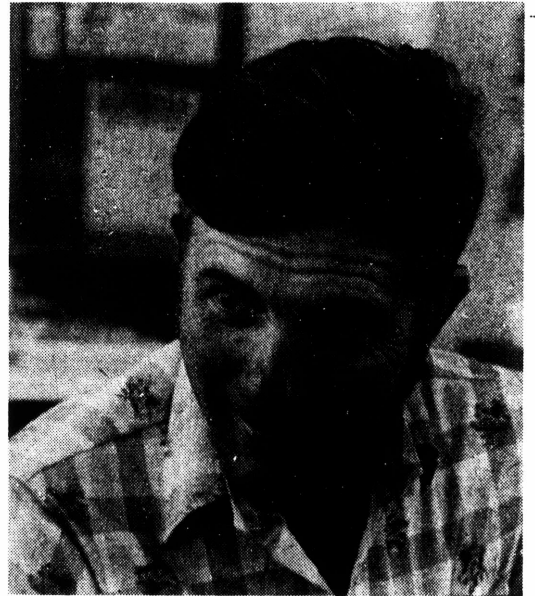

Mista Myron Herman

Sande Lotu

Frank Mihalic

JISAS I GO BEK LONG HEVEN

18 Me 1980 - Luk 24: 46 - 53.

Gutnius bilong tude i stori long Jisas i bungim disaipel bilong em long wanpela liklik maunten. Na bihain em i givim sampela sotpela toktok long ol, em i blesim ol, na em i goap antap na ol i no moa lukim em. Em i go bek long heven, em ples bilong em. . . Na bihain bai em i ples bilong yumi tu.

Bipo em i go, Jisas i givim oda long ol dispela lain manmeri i bihainim em. Em i tok, ol i mas stat long Jerusalem yet, na bihain ol i mas goaut long olgeta kantri na bringim tok bilong God i go long ol pipel. Na tu ol i mas witnes long em.

Em i pasin long olgeta ples, sapos wanpela bikpela man i laik dai, o em i laik go longwe o go olgeta, olgeta manmeri i hangamap long las tok bilong em. Ating em i laik putim wanpela bikpela aida o tingting, o wanpela laik bilong em long bel bilong ol. Na sapos em i gat wanpela laik, o wanpela tok save, o wanpela tambu. . . man, olgeta i mas holim tru. Long ai bilong ol, em i wanpela holi samting.

I wankain tasol long ol disaipel na manmeri i bihainim Jisas. Bihain long sampela wik bai ol i stat long goaut long olgeta kantri nabaut. . . Na long sampela kantri longwe tu. Bai ol i autim tok bilong Jisas na ol i baptaisim ol pipel, na olsem tasol Kristen Sios i bin kamap long olgeta hap. Na tu long laip na pasin bilong ol, ol i witnes long Jisas. Klostu olgeta ol i lusim laip bilong ol long dispela wok.

Dispela las laik na las oda bilong Jisas bilong goaut long olgeta kantri, em i hangamap long yumi tu. Dispela tok i no samting bilong ol disaipel tasol. Planti tausen manmeri bilong olgeta kain Kristen Sios i bihainim dispela tok long laip bilong ol yet. Yu lukluk nabaut na yu lukim hamas misinari bilong ol arapela kantri i wok insait long Papua Niugini. Olgeta wan wan i bihainim dispela las oda bilong Jisas. Ol i pilim em i wanpela oda ol tu i bin kisim long em yet. Na olsem ol i lusim planti gutpela samting long kantri bilong ol, na i kam hia,

Inap long sampela tausen yia nau i gat oltaim sampela lain man na meri i lusim asples bilong ol, na i go bringim Gutnius i go long ol arapela kantri. Bipo, olgeta kantri bilong Yurop ol i no Kristen. Ol i misin kantri. Ol misinari tasol i bringim Kristen bilip na lotu i kam long ol. Sen Pita i go long Itali. Sen Pol i go long Gris. Sen Petrik (bilong Englan) i go long Airlan. Sen Bonifas bilong Englan i go long Jemani. Olsem tasol. . .

Na yu olsem wanem? Yu gat tingting long go autim Gutnius o sanap olsem witnes bilong laip na pasin bilong Jisas? Mi no tok, yu mas lusim asples bilong yu o kantri bilong yu na go. Nogat. Yu ken wok hia yet. Na yu no mas kamap katekis o evanjelis. Nogat. Yu sindaun gut, yu givim gutpela tok na eksampel long ol pikinini bilong yu, na ol manmeri raun nabaut long yu.

TOK SAVE

Tok Save i go long Kupnatu. Man ya i lus longtaim tru. Mi Mondogoye, mi raitim dispela pas. Dispela man i lus o em i raun nabaut long sampela hap long PNG. Dispela man nem bilong em Kupnatu em i raun olsem 23 krismas bilong em. Sapos yu lukim pas bilong mi, orait kam bek long ples. Krismas bilong yu i olsem 23 na yu ting longtaim yu liklik na papa na mama i lukautim yu. Pik i no karim yu na tu dok i no karim yu. Yu mas kam bek long ples na lukim papamama bilong yu. Sapos yu wampela man o meri yu lukim em long sampela hap long P.N.G. Orait, raitim pas i kam long: K. Mondogoye, Swiss Mission, P.O. Box 91, Yokondwale, Kundiawa. Simbu Provins.

Tok Save i go long Mis Silvia Reynolds long sampela hap long PNG. Tok save i olsem: Long yia 1979 long krismas holide mi bin harim olsem bai yu go long Wewak Tisas Koles, tasol long yia 1980 taim mipela i kam bek long skul, mi harim gen olsem pastaim yu bin go long Wewak. Tasol taim yu kisim sik yu trenfea i go long Arawa Tek. Plis long wanem hap yu stap, traim na rait i kam long mi long dispela adres: Miss Ellys Mexy, St. Mary's High School, Asitavi, P.O. Wakunai, NSP.

Salim tok save i kam long:

TOK SAVE,
BOX 1982,
BOROKO.

Stretim Tok

1				2	3	
	4		5			6
7					8	
9		10		11		
12			13		14	
15			16			
17						

Namba 75:

Stret: 1. Samting bilong kukim long lam. 4. Olsem wilka. 7. Ol i yusim pastaim long kirapim Kolman lam. 9. Kain gris i olsem wara. 11. Samting i stap long skai. 12. Nem bilong Japan man. 13. Olsem 'you'. 14. Sotwe long raitim Niu Silan. 15. Hap bilong tebol na sia. 16. Sotwe long raitim Mista long Inglis. 17. Olsem 'tos'.

Daun: 1. Wampela kain wel. 2. Ol pipel i yusim long kantri i gat planti sno tru i stap. 3. Mipela i ken harim long en. 4. Wampela kantri long Yurop. 5. Olsem 'kukim long praipan'. 6. Olsem 'petrol'. 8. Mekim i go long narasait. 10. Yu mas kisim ki long opim en. 11. Nem bilong meri.

Ansa Bilong Namba 74.

Stret: 1. Arestim. 8. Mit. 9. Tisa. 10. Pi. 11. Rais. 12. Kot. 14. Rek. 16. Lire. 17. Tit. 18. Ami. 19. Kiap.

Daun: 1. Ami. 2. Ripotim. 3. Eti. 4. Strafe. 5. Tiara. 6. Isi. 7. Masket. 12. Kala. 13. Tari. 15. Eria. 17. Ti.

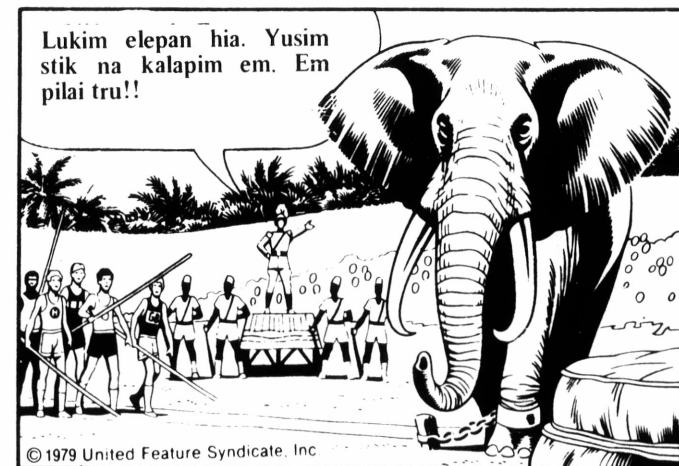

BIABIA





← Lephau long namel yu inap lukim Jonah bilong PWD tim i 60 stret i go long putim kiau long Luteran Yut tim. Sori em i abrus. Traim ken neks taim. PWD i winim pilai.

Namba 7 bilong Balopa i laik katim kona. Tasol em i no inap. Robert bilong Guria i nilim em long hap rot. Guria i gi'vim 6-pela kiau long ol Tarangu ol Balopa i pilai nating.

ENTRY FORM

Makim Bal Pilai Resis

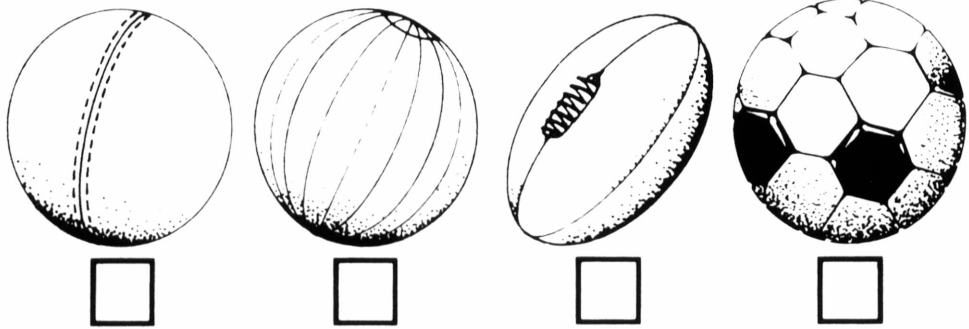

Dispela pilai resis, em i isi tru. Yu inap winim sampela gutpela prais tru.

Lukim ol pilaia antap. Orait, kisim namba bilong wan wan pilaia na putim dispela namba long bal em bai yusim long kain pilai bilong em.

Pinis, orait, bekim tok bilong kwesten daunbilo (nem na adres). Las tru, yu mas raitim nem na adres bilong yu long pepa antap bilong kol pawa peket. Na salim i kam long dispela adres:

**COLD POWER
COMPETITION
P.O. BOX 336
PORT MORESBY**

EM I SAVE WOK
LONG KOL WARA

NEM : _____

ADRES : _____



Wanpela K30 prais long wan wan wik. NA Yu inap winim ol Adidas samting ol long mak bilong K50.

Salim planti long laik bilong yu. Tasol insait long wanpela skinpas, yu mas i gat wanpela resis fom na wanpela pepa antap bilong kol pawa peka. No ken putim tupela or tripela long wanpela skinpas. Olgeta wik, i go inap long 5-pela wik, mipela bai putim ol nem long basket na kamautim wanpela. Nem



bilong husat i kamap, em bai winim K30. Namba 6 wik, olgeta nem bai go insait long basket wantaim nem bilong husat mipela pulim, em bai winim ol adidas samting. Prais bilong ol samting ya, bai i go olsem K50. Mipela bai rait na tok save long ol wina. Man lukautim dispela pilai resis, em tasol i bos.



Philip Wari (wantaim hetben) bilong Yuni tim i kalap resis wantaim Fred Joku bilong Guria long hetim bal.



Liklik Mark bilong GFC tim i wok long trikim fulbek bilong Guria. Ol fulbek bilong Guria no inap long ol trik bilong Liklik Mark. Olsem na em tu i sutim wanpela gol bilong GFC tim.

MASIN BILONG MEKIM YU FRI

Ples bilong yu i gat trabel long painim wara?
Yu gat wari long pawa?

YES

Orait, yu kam long Steamships Machinery na toktok wantaim ol man i save tumas long ol PAWA ENSIN na WARA PAM ENSIN.

Ol ensin hia yu ken karim i go wantaim yu.

HONDA em i ansa bilong yu.

OL HONDA MASIN I MEKIM YU FRI.

HONDA®

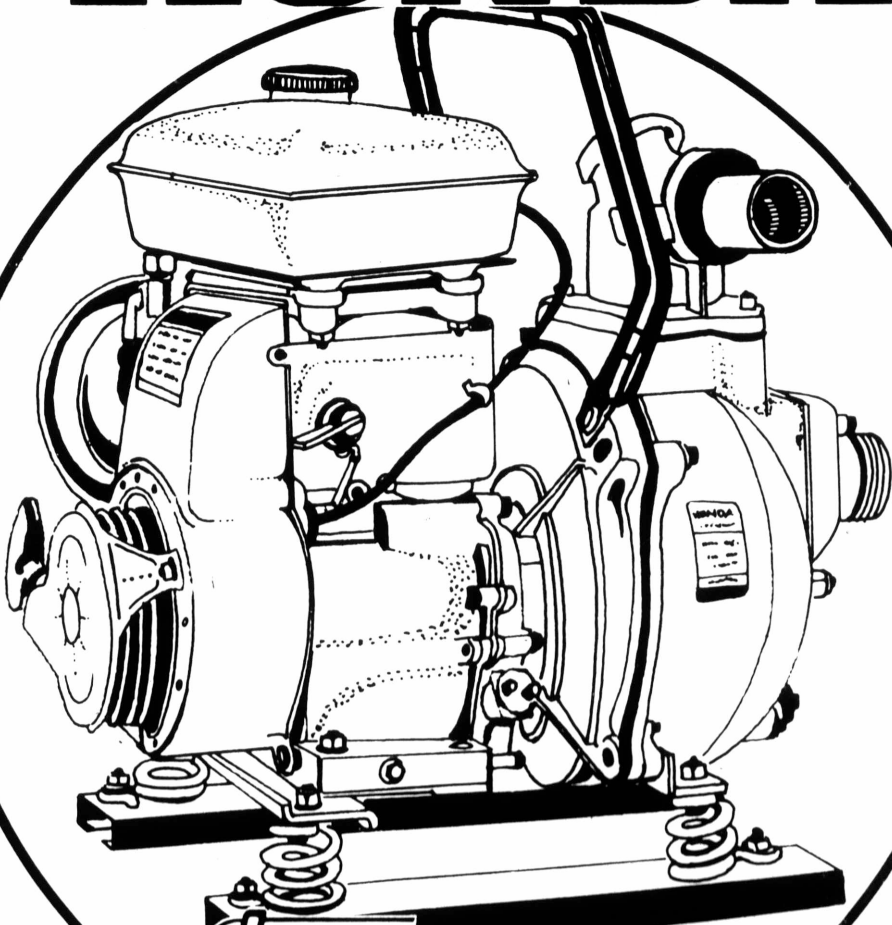

Steamships-MACHINERY

and **HONDA**
dealers

Port Moresby 25 9066
Rabaul 92 1400

Madang 82 2055
Goroka 72 1488
Lae 42 4799

HEBAMO123

Taim bilong G.F.C.

i kam long pes 20.

i sutim tupela gol na Guria i no gat gol. Na long pinis bilong pilai GFC i sutim wanpela moa gol long mak bilong Guria. No gat moa tok; ol i winim pilai. Ol i gat 3-pela gol na Guria ol i no sutim wanpela gol. Ol gol bilong GFC i kam long Samar, na Samson Dagi na Liklik

Mark.

Ol pilai i strongim tim bilong GFC, em long Samar, na Wellington Jojoga na Samson Dagi. Goli bilong Guria, em i pasim planti gol tru. Na arapela tupela pilai husat i trai hat long Guria em, Francis Wabi na Mathew Itaar.

GFC tim, ol i go pas long Mosbi soka nau.

Sko bilong ol arapela pilai, Tarangau i autim tiket bilong Yuni, 2-1. Na PWD tim ol i waraim Semineri, 7-1. Maegin na Kiriwina, tupela i dro, 3-3.

● Rainsau



Em i kas bilong goli bilong Guria, Laky Vavine. Dispela kain stail bilong em i pasim planti gol tru. Em i pilai hat tru long Guria tim. Ol i pilai wantaim GFC long GFC graun.



Samson Dagi bilong GFC tim i wokim wanpela danis ol i kolim, "tapiok dens". Em i amamas long wanem em i sutim pinis wanpela gol. Mathew Itaar bilong Guria i slip na sori tasol i stap long mak bilong em.

Wantok Spot

Taim bilong G.F.C

Bikpela pilai bilong namba wan raun bilong Mosbi soka, em i bin kamap long las wiken. Dispela pilai i bin kamap namel long Guria na GFC. Guria tim i go daun long han bilong GFC tim. GFC tim i givim Guria tripela gol na ol i winim dispela pilai. Guria i no bekim gol bilong GFC.

Tupela tim wantaim i go insait long pilai na hatim pilai stret. Tasol, wanpela samting i no luk orait tumas long tim bilong Guria. Long wanem, ol pilaia bilong GFC i

wok long trikim ol gut tru.

Planti gutpela pilaia bilong Guria husat i save pilai long bek i no stap. Ol pilaia olsem Chris na Pettu na sampela moa i no bin pilai. Ol nupela manki tasol i kam na pilai long bek lain bilong

Guria. Olsem na draipela straika bilong Guria. Andrew Waho i kam sanap long bek lain bilong strongim Guria.

Tasol, GFC em i wanpela tim i gat ol pilaia i pilai soka planti yia moa. Olsem na ol i pilai gutpela

na stail soka tru. Samar, em i wanpela lapun tru bilong GFC.

Na taim em i laik singaut na toktok long ol lain pilaia bilong em, ol i save bhainim gut tru ol tok tok bilong em.

Long pinis bilong namba wan hap, GFC

G.F.C

1 go moa long pes 19.



Robert bilong Guria i tok, "Sori tumas Wellington. Yu inap long trikim ol arapela fulbek, tasol mi inap long savolim yu. So yu mas lukaut long mi." Tasol tim bilong Wellington, GFC i win 3-0.

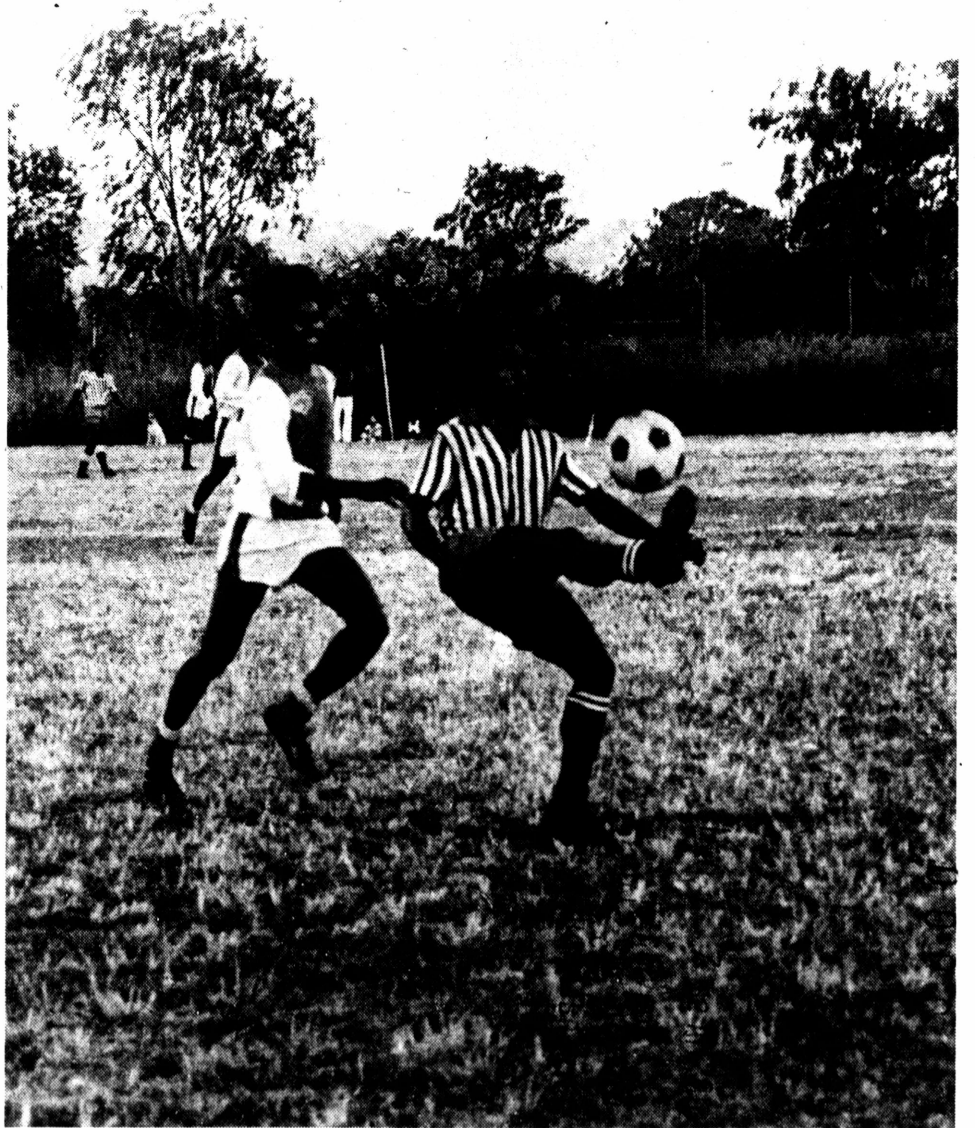

Wellington Jojoga bilong GFC i laik wokim stail long kikim bal i go bek. Peter Meraudja bilong Guria tim i pret long kam klostu. GFC i win 3-0. Ol i pilai long GFC graun long Mosbi, las wik.

AIR NIUGINI

THE NATIONAL AIRLINE OF PAPUA NEW GUINEA

HELPIM KANTRI GOHET



Wantok

Digitized version made available by



Copyright: Under copyright

Rights Holder: Word Publishing Company Limited

Use: This digital version is made available from the UC San Diego Library under a license granted by the Word Publishing Company Limited. This digital copy of the work is intended to support research, teaching, and private study.

Constraints: This work may be protected by copyright law. Use of this work beyond that allowed by the applicable copyright statute requires the written permission of the copyright holder(s). Responsibility for obtaining permissions for any use and distribution of this work rests exclusively with the user and not the UC San Diego Library. Inquiries can be made to the UC San Diego Library program having custody of the work.

Note on digitized version: Some of the digital versions presented here reflects the quality and contents of the microfiche. Problems which have been identified include misfiled or out-of-order pages, illegible text; these problems have been rectified whenever possible.