



No gat Wantok
Wantok bai kamap gen
long wik i stat 28
Septemba, 1985. Bai i
no gat niuspepa neks
wik.

Insait

- Spesel independens nius
- Spesel rugby league news
- Winim K500 - pes 25
- Ol provins i amamas - pes 4 na 5
- Nius pas 2
- Nupela mak bilong PMV - pes 3
- Lukautim bot bilong yu - pes 29
- Ol pas - pes 6 na 25
- Spot - pes 26, 27, 28.

Ol refuji tromoi ston long bikman

BIKPELA BIRUA i klostu long bagarapim wanpela Foren Afeas hetman bilong Indonesia insait long Vanimo ples balus, Wes Sepik Provins long las wik Sarere.

I gat 6-pela Irian Jaya refuji bilong Blakwara refuji kem i gat kot long dispela birua. Long wanem ol i bin sambai long Vanimo ples balus na tromoi ston na hap diwai long dispela hetman bilong Indonesia. Dispela hetman i bin kisim balus long Mosbi na pundaun long Vanimo wantaim 4-pela lain opisal bilong em.

Wanpela refuji man i ran i go klostu long dispela hetman bilong Indonesia. Na dispela hetman i kamautim pistol long hanbek bilong em na poinim long refuji.

Long dispela taim wanpela wokman bilong Douglas Eawes kampani i go sanap namel na rausim dispela refuji. Na emi tokim dispela hetman bilong Indonesia long putim pistol i go insait long hanbek. Pistol i no gat katres long en long dispela taim.

I no gat plisman, sekyuriti opisa o lain opisa bilong Nesenei Intelejen Oganisesen

bilong PNG i was long Vanimo ples balus long dispela taim. Olsem na wokman bilong Douglas Eawes Kampani i ringim Vanimo Plis Stesin. Plis i go kamap long ples balus na holimpasim wanpela refuji tasol. Narapela 5-pela poroman bilong em i ranawe pinis.

Kodineta bilong Melanesian Alaiens Pati long Vanimo, Mista John Tiake i no amamas long harim dispela asua. Em i tokaut olsem dispela biru bai bringim kamap bikpela belhevi namel long Foren Afeas Dipatmen bilong

i go moa long pes 5

Namba 2 wina



Piksa i soim liklik Baeau Doriga wantaim mama bilong em Nido na kandre bilong liklik wina, Pat Momo i amamas long K500 ol i winim.

HUSAT i winim namba tu "Spot The Ball" resis? Em liklik Baeau Doriga tasol.

Baeau em i gat 18 mun tasol na em i painim pinis namba wan laki de bilong em. Baeau i winim pinis K500.

Tru liklik Baeau i no inap long makim yet kain resis olsem long winim K500 prais mani, mama bilong em Nido Wili i bin makim dispela resis na putim nem bilong liklik pikinini bilong em.

Papa bilong Baeau i save mekim liklik bisnis wantaim ol pren bilong em na em yet, Ono Doriga wantaim famili bilong em i save stap long Korobosea, long Mosbi Siti.

"Mipela bai opim nupela pasbuk bilong liklik Baeau mama bilong em Nido i tokim Wantok."

i go moa long pes 5

TRY YOUR LUCK.. K500

Cash
every week
in
Wantok

"Spot The Ball"



Wok bembe i kamap long Nagovis— Not Solomons

KOT i bin sasim pinis wanpela kago kal lida long Not Solomon provins wantaim tupela sas bilong digim bodi bilong wanpela man na mekim ol giaman toktok nabaut i go long ol pipel.

Johannes Avaroko Mavare, krismas bilong em olsem 40, bilong Bakora 2 viles insait long Boku Distrik i bin kamap long Panguna Distrik kot long Ogas 27.

Johannes em i lida bilong dispela kal grup

ol i kolim God-Creation-People-Law-Right em i stap nau insait long Nagovis eria.

Plis i bin ripot olsem Mista Avaroko i bin digim matmat bilong Dokta Luke Rovin long Kokorei viles long Julai 23 long dispela yia.

Plis i ripot olsem ol dispela kago kal lain i bin digim bodi bilong dokta Rovin na lukim

Patrick Matbob i raitim

na bihain ol i bin planim bek gen.

Plis i tok olsem dispela pipel i bin bilip olsem dispela kain pasin bai givim ol pawa na strongim kal grup bilong ol.

Dokta Luke Rovin em i wanpela bilong dispela tupela pablik seven em ol pipel i bin kilim ol long Goroka long 1972 bihain long

ol i bin bamim na kilim wanpela liklik meri krismas bilong em 6.

Dispela narapela man ol i kilim em i wanpela tisa na nem bilong em Peter Moini. Avaroko i bin baim kot long K100 long sas bilong kirapim ol toktok i no tru na i peim K500 beil long sas bilong digim bodi bilong dai man.

Em bai kamap gen long kot long

Septemba.

Dispela kal i bin kamap bipo nai bingro i go inap ol i bin givim dispela nupela nem God-Creation-People-Law-Right long 1982.

Katolik bisop long Not Solomon, Gregory Singkai i tok olsem dispela kago kal grup em i wok bilong wanpela ol longlong man.

Bisop Singkai i ting olsem i gat samting

i go moa long pes 5

BUNGIM 10

PARADISE
COCONUT
CRUNCH O
GIANT
CRACKER
BISKET
KARAMAP



SALIM OL LONG



PORT MORESBY
LAE. RABAUL.

KISIM FRI KALAFUL
ENIVERSERI STIKA



(Sais 200mmx125mm)

Taim Tambu bai stap yet

LONG TAIM ol pipel bilong Mosbi i wok long amamas long ol kain kain samting i kamap long namba 10 independens selebren, ol plisman bai i wok long mekim yet ol wok bilong ol long taim tambu insait long siti.

Plis Komisina na kontrola bilong dispela taim tambu, David Tasion i tok olsem olgeta bikpela pilai na ol arapela samting em bai kamap long taim bilong amamasim dispela independens bai pinis bipo long dispela kefiu i stap long 12 klok nait olsem na bai wok bilong ol plisman i no inap long bagarapim dispela ol bikpela samting.

Mista Tasion i tok olsem ol i laik bai i no gat ol trabel i kamap long dispela wiken insait long siti olsem na ol plisman bai mekim wok bilong ol long was long taim tambu insait long siti.

Mista Tasion i tok tu olsem em i bin tokim Praim Minista Michael Somare



• David Tasion

long dispela tingting bilong em na Praim Minsita i tok orait tasol long progrem bilong ol plisman long dispela taim bilong amamasim independens aniveseri.

Long Mosbi bai ol pipel i no inap long baim ol dring long ol stua long Sarere 14 Septemba i go inap long Tunde 17 Septemba. Mista Tasion i tok olsem ol lo bilong salim ol strongpela dring long ol arapela ples long dispela taim bai i stap yet na i no inap long senis.

Mista Tasion i tok tu olsem insait long Mosbi long dispela wik, i no bin i gat planti trabel i kamap bihain long taim tambu i bin stat. Na em i laik bai wankain samting i kamap long taim bilong independens wiken.

Primia Yanepa laik tambuim bia long Goroka

SAPOS Primia James Yanepa i win long Isten Hailans Provinsal Asembli long politik, Isten Hailans Provinsal Gavman i ken putim bikpela tambu long bia na strongpela dring i go insait long ol pipel.

Em bai namba tu tambu. I gat pinis tambu long kaikai buai long ol pablik ples long Goroka em Primia Yanepa i putim.

Mista Yanepa i tok long Mande 9 Septemba olsem em bai pinisim rot bilong olgeta stua long salim dring long Isten Hailans Provins "bikos wari bilong dring i kamapim planti trabel, birua long rot, na planti arapela hevi i save kamap long taim ol man i dring."

Primia Yanepa i tok em bai askim ol opisa bilong em long mekim wok painimaut long dring long provins bai em i ken kamapim wanpela lo long pinisim dring long go long provins bilong em.

Mista Yanepa i tingting long pusim dispela lo i go insait long narapela asembli kibung bilong ol na kamapim dispela lo long neks yia o sampela taim bihain.

Eksekutyutiv opisa bilong Yanepa, Mista Bill Nakambi i tokaut olsem primia Yanepa i gat bikpela wari long pipel bilong em, bikos planti i no save long gutpela rot long tokim meri bilong ol olsem marit bilong ol i bruk pinis na ol save dring na kamapim kain kain wari long soim dispela hevi bilong ol.

Mista Nakambi i tokaut tu olsem, Primia Yanepa i no laikim dring i bagarapim wok bilong ol pablik sevan long provins bilong em. Mista Yanepa i no laik lukim ol pablik sevan i go let long wok bikos ol i bin dring long nait bipo. Ol dispela kain wari i no save helpim provins i

divelop. Mista Yanepa i tok, Isten Hailans Provins i bin lusim K6 milion long bia na strongpela dring las yia, na dispela yia tu bai luk wankain.

Emi tok, gavman bilong em bai lusim planti winmani tu long taim ol i stapim dring long provins bilong em, tasol em i no wari long mani. "Mi wari long laip bilong ol pipel bilong mi." Mista Yanepa i tok.

Em i tingting tu long putim tambu long smok long Isten Hailans Provins. Na husat kampani bilong mekim smok o promotim ol smok long Isten Hailans bai baim K500 long olgeta wanwan sain ol i putim long provins, sapos dispela lo bilong em i kisim yesa long asembli tu. Mista Yanepa bai statim gen wok bilong bungim het takis long ol manmeri long provins.

Plis holim moa kalabus

SPESEL LAIN plisman em ol i kolim Force 10 i wok long mekim gutpela wok bilong ol insait long holim ol man husat i bin ranawe long haus kalabus.

Long dispela wik, dispela fos bilong plis i bin holimpasim 4-pela man husat i bin ranawe long Bomana haus kalabus.

Plis Kamanda, David Tasion i tok olsem dispela force 10 lain i bin holim ol dispela kalabus long hap bilong Galp na Sentral provins. Na em i tok olsem dispela spesel plis fos bai i wok long mekim gut ol wok bilong ol long taim kantri i mekim ol amamas samting long main 10-pela yia bilong independens.

Long dispela wik Fos 10 i bin holim ol dispela lain husat i bin ranawe long haus kalabus:

Joe Aihi Naime 23 krismas bilong Bereina Peter Inaia Koa 19 krismas bilong Bereina. Em i bin ranawe long Bomana long 1980.

Oroa John Sevese, 16 krismas bilong Malalau bilong Galp provins. Em i bin ranawe long Bomana long 1984.

Jack Numa David Mori, 26 krismas bilong Ihu long Galp provins. Em i bin ranawe long Bomana long yia 1980.

Mista Tasion i tok olsem dispela ol foapela kalabus em Force 10 i bin holim i bringim namba bilong kalabus i go antap long 30 olgeta em dispela spesel grup bilong ol plisman i bin holim long taim ol i bin kirapim long tripela wik i go pinis.

Em i tok olsem dispela wok bilong spesel ol plisman i wanpela bikpela samting long helpim long rausim ol trableman na ol man nogut husat i wok long hait i stap insait long siti. Na tu long bringim bek ol kalabus husat i bin ranawe long haus kalabus na i stap nabaut insait long taun na ol ples insait long Mosbi na ol ples na provins i stap klostu.

PAPUAN SKYLINE THEATRES MOVIE INDEPENDENCE SPECIAL SESSION

WARDS CINEMA TIME START 7.00PM NOW SHOWING UNTIL TUESDAY 17TH

TIME START: 7.00PM SKYLINE DRIVE-IN THEATRE FRIDAY 13TH ONLY SUNDAY 15TH ONLY



A LONE WARRIOR SEARCHING FOR HIS DESTINY...
A TRIBE OF LOST CHILDREN WAITING FOR A HERO... IN A WORLD BATTLING TO SURVIVE, THEY MEET A WOMAN DETERMINED TO RULE.
HOLD OUT FOR MAD MAX THIS IS HIS GREATEST ADVENTURE.

MEL GIBSON IS MAD MAX BEYOND THUNDERDOME Starring TINA TURNER (M)

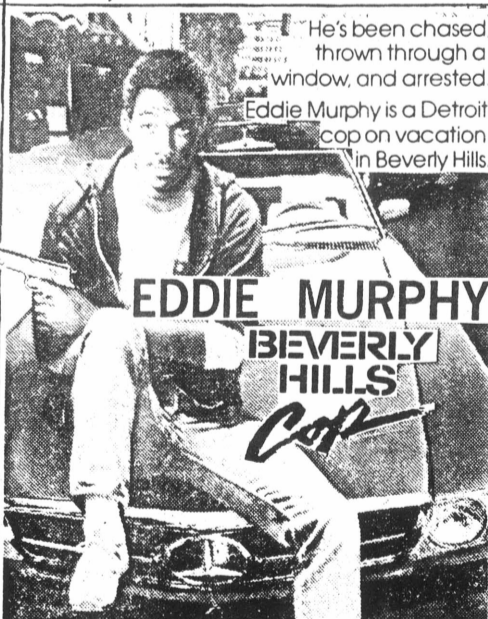

He's been chased, thrown through a window, and arrested. Eddie Murphy is a Detroit cop on vacation in Beverly Hills.

EDDIE MURPHY BEVERLY HILLS Cop

A FRED SCHEPISI FILM ICE MAN A STONE AGE MAN FACING THE REALITIES OF THE 20TH CENTURY... ALL HE WANTS IS A FRIEND. TIMOTHY HUTTON A NORMAN JEWISON

SHOWING ONE NIGHT ONLY GEREHU THEATRE SUN 15TH

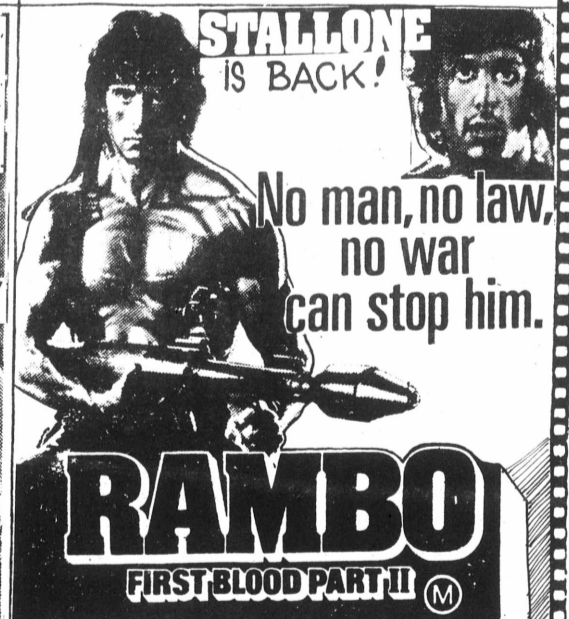

STALLONE IS BACK!

No man, no law, no war can stop him.

RAMBO FIRST BLOOD PART II (M)

THE LAST GREAT ADVENTURE THAT TOUGH MEN EVER DARED! CODENAME WILDGESE LUIS COLLINS • LEE VAN CLEE ERNEST BORGNINE KLAUS KINSKI

SHOWING ONE NIGHT ONLY GEREHU THEATRE THIS FRI 13TH



IF LOOKS COULD KILL... LOOKER



● Praim Minista Michael Somare i toktok long Mosbi In-Sevis Koles.

Edukesen wik

Bikpela bung bilong opim "Edukesen Wik" i kamap long Mosbi In-Sevis Koles long dispela wik Trinde, 11 Septemba. Ol bikman bilong gavman, Praim Minista, Mista Somare, Tony Siaguru, Fainens Minista, Phillip Bouraga na Seketeri bilong Edukesen, Mista Geno Roakeina i stap insait long

dispela bung. Praim Minista Somare i opim dispela Edukesen Wik bihain long em i opim nupela klasrum bilong In-Sevis Koles. Na em i givimaut wanpela nupela buk oli kolim "Growth of Education since Independens, 1975 - 1985." Dispela buk i tok klia long kirap bilong wok edukesen na ol senis i kamap namel long yia 1975 i kam inap long dispela

yia. Bihain long em i opim klasrum, i gat kwaia singsing, bambu ben, singsing tumbuna na Plis Ben i pilai. Olgeta hetman na manmeri i kamap long bung i kisim gutpela kaikai long 12 klok apinun tu. Ol usa na studen bilong Mosbi In-Sevis Koles yet i lukautim dispela bung na mekim kamap dispela bikpela kaikai.

Kampani i bekim tok

BIKPELA tok kros na komplek namel long Mosa Welpam Growa Asosiesen long Wes Nu Briten Provins na Harrison na Crosfield kampani i no nupela samting. Dispela hevi bilong ol i kamap long 10-pela yia bipo i kam inap nau.

Menesing Dairekta bilong Harrison na Crosfield kampani, Mista Peter Gilbanks i

tok em i klia long dispela komplek i kamap long Mista Moses Nahia. Tasol em i no klia long wanem as tru na Mista Nahia i wok long komplek nau. Long wanem olgeta wok bisnis bilong Nu Briten Pam Wel Developmen kampani long mosa i bihainim polisi i kamap namel long kampani na gavman.

Mista Gilbanks i tok Nesanel Gavman i holim 50 pesen sea

insait long dispela welpam bisnis bilong Harrison na Crosfield. Na kampani i holim 50 pesen sea tu. Na i no gat wanpela asua i kamap namel long gavman na kampani long dispela bisnis.

Em i tokaut olsem dispela olpela agrimen bilong yia, 1967 i stap yet. Na long yia, 1983 i gat komplek i kamap long dispela welpam bisnis. Na wanpela gavman tim i bin go sekap long hevi. Tasol i

no gat asua. Kampani i bin mekim kamap bisnis aninit long olgeta polisi bilong Nesanel Gavman na Dipatmen bilong Praimeri Industri. Mista Gilbanks i tok Mista Nahia i gutpela man bilong tingting na autim toktok. Tasol nau, em Mista Nahia i popaia tru. Na Mista Gilbanks i bilip olsem Mista Nahia i wok long mekim ol dispela komplek nau long pasin bilong wok politik.

Em i tok Mista Nahia i toktok tasol long traim kisim sapot bilong pipel. Na em i kain pasin ol provinsal gavman memba i save mekim kamap tude.

Dispela bisnis bilong welpam namel long Nesanel Gavman na Harrison na Crosfield i no samting bilong Mista Nahia. Olsem na i no gat as tru long Mista Nahia i komplek. Sapos em i no amamas long dispela toktok, Mista Gilbanks i askim em long kisim wari i go long Dipatmen bilong Praimeri Industri o Nesanel Gavman.

Wel pam asosiesen i laik gavman i sekap long kampani

I GAT bikpela singaut long Nesanel Gavman i sekap long tok orait long wok bisnis bilong Harrison na Crosfield kampani insait long Mosa welpam eria bilong Wes Nu Briten Provins.

Ben Wauns i raitim

Dispela singaut i kamap long provinsal gavman memba bilong Mosa, Mista Moses Nahia. Em i bilip Harrison na Crosfield kampani i abrusim tok orait na kirapim arapela bisnis na paulim ol lokal pipel na papa bilong ol welpam blok.

Mista Nahia i tokaut olsem dispela kampani i abrusim bikpela tok orait bilong Pam Wel (Nu Briten) Agrimen bilong yia, 1967.

Kampani i bin sainim dispela agrimen wantaim PNG Gavman. Na long dispela taim bipo, kampani i go pas long Nu Briten PNG

Gavman. Na long dispela taim bipo, kampani i go pas long Nu Briten Pam Wel Developmen Limitet husat i kirapim Mosa Wel Mil Pty Limitet. Na em i wok traim bilong mekim pailot projek bilong welpam insait long Mosa na Hoskins eria.

Mista Nahia i komplek olsem dispela agrimen i no bin senis namel long PNG i kisim independens na kirapim provinsal gavman na larim lokal pipel i go pas long bisnis long eria bilong ol. Em i tok dispela agrimen long bipo i stap yet. Tasol Harrison na Crosfield i go het na kirapim 4-pela bikpela welpam plantesin gen.

Mista Nahia i tok, "Nesanel Gavman i mas lukluk gen long dispela agrimen. Long wanem kampani i yusim ol lokal wokman long pulim profitmani bilong en yet. Dispela 4-pela plantesin long Nevarai, Togulu, Kubango na Malmimi i no stap insait long kain wok bisnis aninit long agrimen.

"Dispela kampani i lusim K4 milion long kirapim Kubango wel

mil faktori tu. Tasol ol i kisim tok orait bilong kirapim dispela faktori long wanem hap? Ating ol i gat mekim nupela tok orait wantaim Nesanel Gavman gen o olsem wanem? Mi no klia yet long dispela.

"Dispela kampani i wok long resis strong wantaim ol lokal welpam growa na papa bilong ol liklik welpam blok nau. Ol i putim kamap kain kain prais na takis bilong dispela welpam bisnis."

Mosa welpam eria i pulap long manmeri bilong olgeta hap bilong Papua Niugini. Namba bilong pipel, em 12,500. Na ol i bung insait long 6 hektea graun bilong stelmen blok. Tasol dispela lain pipel i gat behevi. Long wanem dispela bikpela kampani i kontrolim bisnis na givim hatpela taim long pipel i pulim mani na lukautim famili na baim kain kain takis.

Mista Nahia i tok, "Mi glasim olsem dispela kampani i no givimaut winmani long ol growa na smolholda bilong en namel long yia, 1967 i kam inap nau. Ating kampani i save baim gavman takis

tu o? mi no save. Tasol em i narapela samting namel long kampani na Nesanel Gavman.

"Asosiesen i givim dispela komplek i go long gavman bipo. Na tupela saveman bilong lo, Mista Peter Donigi na Bernard Narokobi i kam lukluk insait long dispela hevi pinis. Tasol mipela ol memba bilong asosiesen i wet yet long kisim gutpela bekim.

Mista Nahia i tok, Nesanel Gavman bai givim gutpela sevis long em yet, provinsal gavman na ol growa, sapos ol i lukluk gen long wok bisnis bilong dispela kampani. Em i memba bilong dispela konstituensi na em i laik bai Nesanel Minista bilong Praimeri Industri o Namba Tu Praim Minista o Praim Minista long kam na lukluk long dispela hevi bilong ol.

Mista Nahia i siaman bilong Asosiesen tu. Na em i tok bai em i no inap malolo o slip gut i go inap long taim Nesanel Gavman i harim singaut bilong em na sekap long dispela hevi bilong ol welpam groa.

Mak bilong PMV Asosiesen

OL PMV operetas i memba long Pot Mosbi PMV Asosiesen nau i gat nupela "stika" long fran na sait long bas bilong ol. Dispela ol nupela stika antap long bas i soim olsem ol dispela bas i bilong operetas i stap insait long dispela Asosiesen.

Na i bilong soim ol plis long luksave tu. Long wanem bipo i gat planti komplek long pasin bilong ol bas i ran long rot. Na i save

sutim toktok dabolim olgeta lain PMV operetas.

Olsem na ol bilong Pot Mosbi Asosiesen i laik soim ol yet klia long publik na Len Transpot Bot wantaim olsem ol wanem hevi i kamap bai mas makim stret papa bilong bas na wanem PMV Asosiesen bilong em.

Dispela stika i gat mep bilong PNG wantaim tupela pisin Kumul na PNG flag i

stap antap. Kumul long ret kala, mep long yelo na flag long wankain kala yet blak, ret, yelo na 5-pela waitpela sta.

Na olgeta dispela i stap antap long blupela kala. Ausait i raunim nem bilong Asosiesen. Eksekyutiv bilong Asosiesen, Mista Absolom i tok olgeta memba bilong Aso-

i go moa long pes 14

"Westap takis kliarens setifiket bilong yu?"

Olsem wanem! PMV bilong yu i no ran gut moa? Yu save baim bikpela takis tumas tu?

Coopers & Lybrand bai helpim yu long stretim ol dispela takis na soim yu long rot bilong baim liklik takis tasol. Lukim Coopers & Lybrand nau tasol na putim PMV bilong yu long stretpela rot gen.

OFFICE		
Baroko	25 8644	Lae
Port Moresby	21 1500	Madang
Arawa	95 1355	Mendi
Goroka	72 1177	Mount Hagen
		Rabaul
		Wewak
		42 2644
		82 2262/82 2573/82 2680
		59 1111
		52 1092/52 1664
		92 2322
		86 2692/86 2577

Lukluk Bek Long 10-pela Yia

Insaik long 10-pela yia i kam inap nau, stat long 1975, kantri bilong yumi i bihainim wanem rot tru?

Long taim plak bilong PNG i kisim ples bilong plak bilong Australia long ol diwai pos long skul na haus bilong ol kiap long ol gavman stesin insait long PNG, planti manmeri long ol viles i bin kisim ol kaikai na klos samting bilong ol na ranawe i go long gaden haus long bus. Ol i ting kantri i senis nau na nogut bai i gat namba tri bikpela pait i kamap long yumi.

Tasol sampela yia bihain meri bilong ol i karim na dokta wantaim nes i givim gutpela marasin na planti pikinini no dai. Ol mama tu i no dai olsem bipo. Ol i lukim olsem ples i wok long pulap long ol yangpela manmeri na ol skul tisa i save hatim papamama long kisim pikinini i go long skul.

Nau, ol skul tisa i senis gen na tok olsem ples i pulap na i no gat ples long putim pikinini bilong mi long skul. Em wanem kain developmen? Sampela yia bipo, namel long dispela 10-pela yia bilong Independens, ol yangpela i wok long go long taun long painim wok. Planti i raun nating na ol i kalabus. Em wanem kain developmen?

Samting olsem 5-pela yia i go pinis, ol yangpela i save pretim plis na bikpela wari bilong ol em plisman. Nau bihain long 5-pela yia, ol plis i no moa pretim ol yangpela na, nau, i gat wari bilong yangpela. Mipela harim planti trabel i kamap na plis i sot long ol taun gen. Em wanem kain developmen? Long taim bipo, mipela i no save harim tumas long redio na ritim long niuspepa olsem ol lida bilong mipela i pulim bikpela mani. No gat man i bin go kalabus long stil long gavman. Tasol nau, klostu olgeta mun, bai wampela nius olsem i kamap.

Nau, 10-pela yia bilong independens i go pinis, yumi wok long kisim bikpela helpim mani yet long Australia. Bai yumi mekim olsem yet insait long narapela 10-pela yia? Em wanem kain developmen?

Kantri bilong yumi i bihainim wanem rot tru? Nau em taim bilong senis. Yumi mas gat trupela kristen lida long olgeta kain wok. Yumi mas bungim tingting wantaim long olgeta kain wok. Putim pren bilong yu pas bai yu orait.

Ol provins i redi long independens selebresen

Manus

INDEPENDENS FIVA i kamap pinis long Lorengau taun. Siaman, bilong komiti, Joe Hilarai i tok, "Yu ken pilim stret."

Gavman bot i bringim pinis ol pipel bilong Wu'vulu, Aua ailan na Hemits wantaim Ninigo grup na ol i wok long raun i go i kam stat long wampela kona bilong Lorengau taun i go long narapela.

Mista Hilarai i siaman bilong Independens Avinvesari komiti long Manus. Na em i tok dispela em i bikpela bung wantaim na olgeta provins na pipel long Papua Niugini i amamas wantaim.

Long Manus olgeta samting bai kamap long Lorengau taun stret. Komiti i stretim rot pinis long kisim wampela, wampela grup, long stap insait long kain kain spots, tumbuna singsing, stringben resis, kwaia singsing, kanu resis i kam long olgeta 15 konstituensi bilong provins.

Em i tok komiti yet bai painim rot bilong ol pipel i stap long ol

dispela pilai na singsing resis long go long Lorengau taun.

Na komiti yet i redi ples bilong ol long slip long ol dispela taim bilong bikpela bung wantaim o "Selebresen" long Manus.

Tasol, Mista Hilarai i tok sapos ol pipel ilaik tasol long ol samting i kamap long Lorengau, bai ol i painim rot na ples bilong ol yet long wokabaut.

Ol pipel husat bai stap insait long ol kain kain pilai bai slip long olpela maket ples, risot senta na Sa'arhat ples. Komiti i redim dispela ol 3-pela eria long ol pipel i kam long dispela 15 ilektoret long stap long taim ol i kamap long Lorengau taun.

Mista Hilarai i tok, bai i gat Mis Manus resis tu. Ol yangpela meri long olgeta ilektoret bai bilas long ol tumbuna bilas na resis long kamap Kwin bilong Manus.

Ol meri long provins tu bai sanapim ol liklik haus bilong ol na salim kaikai, ol han krap na kain kain wok em oleyet i mekim. Manus Provinsal Kaunsil ov Wimen, ol komyuniti

na distrik wimens klap bai sanapim liklik haus kaikai na wok samap, na hankrap.

Ol dispela pilai bai kamap long Prins William pilai graun long Lorengau taun.

Bai i gat ol singsing grup bilong ol pipel long arapela provins i stap long Manus. Bai i gat Nu Ailan singsing grup, Is na Wes Sepik, Madang, Morove, Is na Wes Nu Briten na ol Not Solomons pipel husat i stap long Manus i kamapim singsing tumbuna bilong ol yet. Tasol ol 15 ilektoret bilong Manus bai i gat ol singsing bilong ol yet tu.

Namel long ol bikman husat bai givim toktok long dispela bung wantaim em Minista bilong Korektiv Institusen Sevisis, Mista Arnold Masipal. Em yet tu i memba bilong Manus rijinal. Na namba-tu Primia, bilong Manus Mista Tasciusus Kasou tu bai toktok long dispela bung long Lorengau.

Bikpela mas bilong ol skul studens na singsing grup bai kamap long Mande, 16, Septemba stret. Na 3-pela platun bilong Difens Fos long Lombrum bai i go pas long dispela mas.

Bihain long olgeta samting primia, Mista Steven Pokawin bai pasim bikpela bung wantaim long Tunde apinun, 17, Septemba. Na long nait bai i gat bikpela kaikai tru bihain long ol i givimaut ol prais bilong kain kain resis.

Dispela kaikai ol kolim "Lapan kaikai." I gat ol pik, 2-pela bulmakau, kaukau, taro, banana, saksak na ol kain kaikai i redi.

Lapan bilong Manus yet bai tilimaut ol kaikai i go long olgeta pipel husat i stap insait long ol resis, na singsing, long Lorengau taun na 15 ilektoret. Na ol lida bilong ol grup yet bai tilim ol kaikai ya i go long wan, wan manmeri long grup bilong ol.

Dispela Lapan kaikai i mak bilong tok gut bai long gutpela taim bilong olgeta Manus pipel na husat ol arapela lain i stap long dispela bikpela bung wantaim.

Olgeta samting bai stat long Trinde, 11, Septemba na bai i go inap long Tunde, 17, Septemba.

Progrem bilong Wes Sepik i stap long pes 28. Na bilong Nu Ailan Provins i stap tu long pes 28.

Is Sepik

IS SEPIK Provins i gat bikpela progam tru bilong ol. Program i stat long Fraide, 13, Septemba wantaim resis long painim pis long solwara long bikmoning tru em long 5 klok yet.

Dispela taim tu bai Is Sepik, Agrikalsa, Industrial na Kalsa So i kamap. Dispela wik tu i makim Is Sepik Provinsal Gavman De long 16, Septemba.

Ol pipel long Is Sepik bai amamasim namba 10 yia bilong PNG Independens long ol distrik na komyuniti bilong ol yet. Tasol husat ol grup o pipel i kamap long Is Sepik So tasol bai bung long Wewak taun.

Long Sarere bai i gat kanu resis i stat long poin Sup i go insait long Wewak basis long bikmoning yet. Bai i gat prais long dispela resis. Dispela resis i bruk long tupela hap. Wampela hap em i bilong ol kanu i gat 3-pela man. Na narapela hap em bilong ol kanu i gat 5-pela man. Bai i gat resis bilong

ol man em bai karamapim 10 kilomita na ol meri em 6 kilomita. Na ol dua long Is Sepik Provinsal So bai op long 8 klok moning long Sarere long Prins Charles pilai graun.

Bai gat paia pait we ol paamen bai putim so long we bilong mekim indai bikpela paia. Pilo pait, gris pik resis long holim pasim pik em skin bilong em i pulap tru long gris, resis long Brek Dans King na Kwin, pawa ben, na resis bilong katim diwai, pulim rop (tug of war) netbal, soka na volibal.

Is Sepik So bai fri long ol pipel i raun lukluk long ol samting i kamap long So. Bai i no gat pe long baim dua long raun insait long so graun.

Long Sande bai ol wan, wan Sios i mekim lotu long makim 10-pela yia Independens bilong kantri. Na ol kain kain sapot bai gohet long dispela de.

Resis bilong gris pik i gat wampela prais tasol. Husat man i holim pik ya em prais bilong em nau.



● Ol meri Yuo long Is Sepik i hatim singsing.

Long Mande, 16, Septemba bai ol skul studen, sevis manmeri, na ol Difens Fos soldia bai karim Nesenel plak na mas long Pora graun i go kamap long Prins Charles graun.

Klostu long 10 klok samting bai ol bikman i givim toktok. Ol singsing tumbuna long dispela taim bai i no gat prais. Tasol Independens na so komiti bai givim sampela kain presen long ol singsing grup i stap insait long dispela bung wantaim.

Long 7 klok nait samting bai Semba ov Komes brans long Wewak sutim ol spesel paura i go antap long klaud long makim namba 10 krismas bilong PNG.

Na long 8 klok nait bai i gat bikpela danis pati. Na 12 long klok nait tru bai ol i katim anivesiari o betde ket long dispela pati.

Long Tunde, 17, Septemba bai ol i pinisim olgeta spot em i no pinis yet. Na husat ol pipel i kam longwe

bai stat long go nabaut long distrik o ples bilong ol. Ol pipel bilong Wewak taun yet bai malolo gut long dispela de.

Dispela em ol bikpela samting bai kamap long Wewak. Em progam i stap anit long Provinsal Independens Komiti Siaman, Mista Paul Bengo, namba tu Leptenen Kanel, Perry Iruru. Siaman bilong So Komiti, Mista Peter Waliawi. Na infomision opisa, Misis Monica Power i salim i kam long Wantok.

WANTOK NIUSPEPA
 Nius i kamap 52 taim long yia

Opis bilong edita na edvetaising long PNG
 P.O. Box 1982, Boroko
 Telepon: Mosbi - 25 2500.
 Teleks: NE 22213
 Edvetaising - Telepon: 25 2500

PE BILONG WANPELA YIA, 52 NIUSPEPA

Ples	Air	Surface
Port Moresby	K20	K20
PNG	K29	K29
Australia & Sol Islan	K60	K39
New Zeland & Pacific	K78	K46
America & Europe	K118	K60

Printed and published by Rowan Sidney Callick, of Winter street Granville, at Allotment 2, Section 209, Hohola.

Daisy Cares
SUPPORT HANUATEK
 We stock

T-SHIRTS: Low cost, personally designed cotton t-shirts.
 Cane furniture: High quality, low cost furniture made to order.

Visit HANUATEK yourself (next to Badili Vocational School) or phone:
 HANUATEK 21 3565
 SPATF 21 2744

Not Solomons



I kam long pes

Indonesia insait long Jayapura na PNG Gavman. Long wanem wok sekyuriti bilong lukautim ol dispela opisa insait long Vanim ples balus i slek.

Mista Tiake i tok Foren Afeas Opisa bilong PNG long Mosbi i bin holim kibung wantaim ol dispela wanwok bilong Indonesia long las wik. Na dispela lain opis bilong Indonesia i kisim balus na go long Vanimo. Tasol watpo na lain plisman o sekyuriti opisa i no sambai long lukautim ol dispela opisa bilong Indonesia?

Dispela wokabaut bilong Indonesia

hetman em i samting i kamap namel long Foren Afeas opis long Mosbi na Jayapura. Tasol na emi no klia long wanem kain rot i mekim ol dispela refuji i klia long dispela raun bilong Indonesia hetman. Em i wanpela bikipela askim Mista Tiake i no klia long en.

PNG Foren Afeas opis long Mosbi i tokaut olsem dispela birua i bin kamap. Tasol i no gat wanpela birua o bagarap i rong dispela hetman bilong Indonesia o lain opisa bilong em. Olsem na i no gat hevi.

Dispela opisa long Mosbi i tokaut tu olsem dispela lain opisa bilong Indonesia i kam

stretim toktok bilong boda agrimen wantaim Foren Afeas hetman bilong PNG long Mosbi. Tasol dispela lain opisa bilong Jayapura opis i kamap long Vanimo na bunggim birua. Tasol i no bikipela bagarap i kamap, olsem na no gat wari.

Mista Tiake na lain wokman bilong Douglas Eawes kampani i no klia long nem bilong dispela lain opisa na hetman bilong Jayapura. Foren Afeas opis long Mosbi i no tok klia long nem bilong ol tu.

Provinsal Plis Komanda bilong Wes Sepik, Sief Suprintenden Joel Kean i bin kisim ripot bilong

SAPOS vu-draw raun long Arawa taun long nait. Bai vu mangalim tru oi bikrot i lait gut tru wantaim oi kala kala fait.

Independens Komiti siaman, Peter Tsiamalili na ol lain bilong em i bilasim pinis ol bik rot long Arawa wantaim ol kain kala fait. Na long nait Arawa taun i save sain gut tru.

Dispela provins bai i no inap amamasim tasol Independens bung wantaim singsing tumbuna, string ben resis rok o, pawa ben na ol narapela kain kain samting i stap long program.

Nogat. Dispela yia 1985 bai i stap long stori bilong Not Solomons Provins. Na long Arawa taun long Resev Botonikal Gaden, ol i sanapim pinis bikipela "Simen ston."

Mista Tsiamalili i tok, dispela simen mak i gat 19 liklik simen blok i sindaun antap tru long en. Em ol i makim ol 19 provins bilong PNG. Na arere na long ol sait, sait bilong dispela ol 19 simen ston bai wari i sut i go aut na ron arere long dispela bikipela simen mak.

Wara i kapsait olsem i makim ol gutpela wok bilong ol 19 provins na kantri long ol 10-pela yia stat long 1975 i kam inap nau 1985, na long tam bihain tu.

Not Solomons i wanpela Provins tasol i sanapim wanpela kain mak olsem long makim 10-pela yia bilong Independens.

Mista Tsiamalili i tok, ol pipel bilong Not Solomons bai amamasim Independens long ol distrik na komyuniti bilong ol yet. Komiti bilong em i givimaut pinis K400 long ol 9-pela distrik. Na ol i givim K200 long ol wan, wan 49 komyuniti gavman long ranim program na bung wantaim

dispela birua tu. Tasol em i salim ripot long teleks i go bek long Plis Hetkota long Mosbi. Na em yet i no laik tok klia long dispela birua.

Em i tok em i samting bilong Plis hekota long tokaut long en.

Pablik Rilesen Divisen long Plis hetkota i no gat wokman i sambai long tok klia long dispela ripot. Ol i no givimaut ripot bilong idispela birua namel

long Mande, 9 Septemba i kam inap long dispela wik Fonde (12 Septemba).

Wantok i askim Indonesia Embasi opis long kisim tok klia long dispela birua. Tasol lain opis na ambasada i gat bikipela kibung long dispela wik Trinde. Na em i hat tru long Wantok i kisim gutpela toktok bilong ol long dispela birua.

bilong ol yet.

Olgeta samting bai stat long Fraide 13 Septemba we olgeta kain pilai bai kamap. Tasol long Mande, 16, Septemba em ol bikipela samting tru bai kamap.

Bai i gat wanpela riletim resis we ol tim bai karim toktok i go long Not Solomons i kam long Praim Minista Somare. Dispela tim bai kisim dispela toktok long Kieta ples balus na ron i go kamap long Primia Dokta Alexis Seri. Na Premia bai kisim dispela toktok nau tokaut long ol pipel wanem samting Praim Minista i tok long ol pipel bilong Not Solomons.

Ol bikman na meri husat bai givim toktok em Mista Paul Nerau, siaman bilong Arawa Taun Autoriti, Mista Siru Tivai, bos bilong ol komyuniti gavman, Misis Pauline Onsa, makim ol meri, Mista Sam Tulo, Minista bilong Edukesen i makim Nesanel Gavman.

Primia Alexis Sarei bai toktok las tru. Tasol bai em i wet inap em i kisim dispela tok save i kam long Praim Minista, em ol Relei tim bai karim i kam long Kieta olsem long Olympik stail.

Wiken i stat long Fraide 13 Septemba bai i gat ol spot, singsing grup string ben na rok ben, brck dans resis.

Dispela Monumen o simen mak nau i sanap pinis long kona bilong Arawa maket na haus sik we botonikal gaden i stap long en. Na Dokta Sarei yet bai opim bihain long em i givim toktok bilong em long ol pipel.

Olgeta samting bai pinis long Mande 16 Septemba. Na long Tunde bai ol i malolo nabaut. Tasol bai i gat soka tim i kam long Solomons Ailan long pilai long Tunde, 17, Septemba.

I kam long pes

olsem 300 pipel insait long 2,000 pipel long Nagovis eria i wok long bihainim dispela grup.

Em i tok dispela grup i bilip long pasin bilong onerim ol tumbuna olsem na ol i wok long digim ol bodi bilong ol dai man.

Bisop i tok ol lain pipel i no bin bilip olsem ol dispela tupela pablik sevan i bin dai

long 1972 olsem na ol i bin digim dispela bodi bilong Dokta Rovin.

Ol narapela eria long Not Solomons i bin gat kain kain kal grup olsem bipo na nau dispela pasin i kamap long Nagovis eria.

Bisop Singkai i tok dispela kain kago kal i kamap long ol lain pipel husat i no gat save na i save bilip olsem ol i ken kamap nating.

Isten Hailans

PLANTI tausen pipel bai bung long Goroka long amamasim PNG Independens betde. Olgeta samting bai stat long Fraide 13 Septemba na pinis long Tunde 17 Septemba.

Namba tu seketeri bilong Isten Hailans, Mista Togi Bau i tok long bringim tu moa amamas, Nesanel Volibal Sempionsip i kamap tu long Goroka long dispela Independens wiken.

Ol kain kain pilai, na singsing grup bai kamap long Nesanel Spots Institusen (NSI) graun long Wes Goroka. Nesanel Volibal sempionsip tu bai kamap long dispela graun tasol.

Long Sande 15 Septemba bai olgeta sios long Goroka i bung wantaim na holim wanpela bikipela lotu tru long NSI graun. Long apinun

bai spots na singsing tumbuna i kamap.

Tasol i no gat string ben o pawa ben resis.

Long Mande, 16, Septemba, bikipela de tru husat manmeri i sevis tru long wok bilong Provins na kantri long ol yia i go pinis bai kisim Independens Anivesari medal.

Isten Hailans Rijinal memba, Sir Barry Holloway bai bikman bilong ol long givim toktok. Na long Tunde apinun bai Prmia, Mista James Yanepa i pasim bikipela bung wantaim bilong provins.

Mista Bau i tok Isten Hailans Independens Komiti i painim hat long kisim ol bikman bilong narapela kantri o ol Nesanel Minista bilong narapela provins. Bikos planti bilong ol Gavman Minista bai i stap long provins bilong ol yet. Na tu bai ol i stap insait long ol

samting i kamap long Mosbi.

Olsem na Rijinal memba bilong ol Sir Barry Holloway yet bai bikman bilong ol long givim Independens toktok.

Komiti i bihainim toktok bilong Nesanel Independens Komiti yet. Planti provins bai i gat ol nesanel memba o minista wantaim ol premia arapela ol provinsal lida yet bai givim toktok na i stap amamas wantaim ol pipel bilong ol.

Isten Hailans program bai pinis bihain long ol i givimaut prais bilong ol kain kain spot na resis long Tunde 17 Septemba. Nesanel Volibal sempionsip gren fainal bai kamap long Mande apinun. Program bilong ol i pulap tru long spot na no gat inap arapela resis bilong singsing tumbuna, gita, pawa ben na ol arapela resis.

**PNG's Past is our past.
PNG's Future is our future.**



LAE PHOTOGRAPHY PTY LTD

**Congratulates the people of
Papua New Guinea on their
achievements.**

**We are looking forward in confidence to the next 10 years
of progress.**



Watpo senisim nem nau?

Dia Edita — Askim bilong mi i go long Praim Minista Mista Michael Somare.

Long wanem as tru yu laik senisim nem bilong kantri? Papua New Guinea i wanem kain kantri?

Em i wanpela komunis kantri o wanem kain kantri tru? Na yu ting ol manmeri long PNG bai amamas tru long yu long taim yu senisim nem bilong PNG?

Na yu tu bin salim ol wokman long lukluk

raun long olgeta hap long PNG. Dispela kantri i no bilong wanpela man tasol na tingting bilong wanpela man i nogut stret.

Mi no klia tru long dispela tingting bilong senisim nem. Mi save planti manmeri bai resis long winim K5,000 na mi ting em i wanpela samting long grisim ol manmeri bilong esnsim nem bilong kantri.

Na bilong pinisim toktok bilong mi, mi laik Praim Minista i

mas tokim ol manmeri bilong Papua New Guinea long wanem as tru em i laik senisim nem bilong kantri. Na watpo yu no bin senisim long taim yumi bin kisim independens long 1975 bikos long dispela taim yu bin

stap olsem Praim Minista.

Sapos yu wanpela man o meri i laik sapotim tingting bilong mi bai em i gutpela tru.

Mathew Mai, Wewak, ESP.



Larim nem PNG i stap

Dia Edita — Bilong wanem na Michael Somare i laik senisim nem PNG i go long ol narapela nem nabaut?

PNG em i gutpela nem tru na sapos yumi senisim i go long narapela nem nabaut bai PNG gavman i westim bikpela mani tru na tu bai PNG gavman bai senisim planti nem olsem PNGBC, PNG Difens FOS, nesenal entem na ol narapela samting moa. Olsem na mi laik askim PNG gavman long no ken senisim PNG i go long narapela nem bikos PNG em i gutpela nem tru.

Paul Peri, Kieta, NSP.

Karimui i drip namel

Dia Edita — Mipela i laik sapotim pas bilong brata Patrick Kamun Aibe bilong Bus Papua.

Yes tok ol kalsa bilong Simbu na tok ples na ol arapela samting ol Simbu i wokim em yupela i no save. Em i tru brata.

Mipela i ful sapot stret long yu bikos

Simbu gavman i no save luk strong long hap long mipela.

Kerema gavman i lukautim mipela bipo tru na Simbu gavman i kam kisim mipela nating. Simbu gavman i save tingting long sait long em yet na i no save tingim mipela ol bus pipel.

Mipela i gat wanpela

rot na em balus tasol. Na yu save Karimui i pulap long kain kain samting bilong kisim mani tasol balus i save pulap na pasim ples bilong pasindia.

Olsem na traim helpim memba bilong mipela o sapotim memba bilong mipela na wokim rot i kamap hariap long Karimui.

Nogut bai mipela pasim ples balus na mipela bai bruk lusim Simbu.

Karimui em i gat planti viles na planti tok ples. Tasol mipela i gat tupela bikpela tok ples em Yasa na Daribi.

Hambo Bawia, Nolu viles, Karimui, Simbu.

Salim pas i kam long:

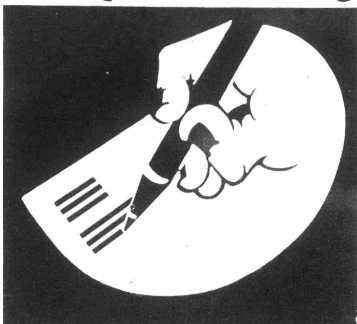

WANTOK NIUSPEPA PO BOX 1982 BOROKO

Narakain rul bilong skul Pe bilong balus dia tumas

Dia Edita — Bipom i bin stap long wanpela vokesenel trening senta ol i kolim Raval long Rabaul.

Mi save bungim ol dispela kain problem na em i rul tru bilong edukesen o ol i save giaman tasol?

Namba 1, Het tisa i save tok no gat manki long narapela provins bai kam skul long dispela senta.

Namba 2, Olgeta mun mipela i save givim K12 long het tisa.

Namba 3, Het tisa i save paitim ol studen wantaim han bilong em.

Namba 4, Mipela ol studen i save piksim ol ka na wokim ol bikpela haus bilong ol man long ausait. Na wokim ol tang wara na ol sampela kain ol liklik samting na mipela save pulim bikpela mani tru i kam long skul.

Na het tisa i save pusim mipela yet long baim ol tuls bilong mipela. Na long sampela vokesenel senta

em long taim ol i laik greduet long skul bai skul i redim tuls wantaim boks. Tasol long dispela skul ol i save givim mipela boks nating.

No gat tuls na mi lukim olsem i no rul bilong edukesen. Ol dispela kain kain rul o pasin em i mas kamap tasol long dispela senta.

Timmy N. Alop, Not Solomons Provins.

Dia Edita — Mi laik sapotim pas bilong brata ya Niwai Komis i bin kamap long Wantok Niuspepa namba 576.

Emi tok pe bilong balus long Wau na i go long Sim i antap tumas. Em i tru olsem long Wau na i go long Sim i no longwe tumas olsem na pe bilong balus i antap tumas.

Mi bin go pinis long dispela hap na mi lukim disten bilong Wau na Sim i no longwe. Mi kisim Co-Air long Wau samting olsem hap pas siks na mi go kamap long Sim long 5 pas 7.

Em i luk olsem i no longwe. Dispela i luk olsem kampani i kisim bikpela mani nating na tu long taim ol pipel yet i wokim ples balus watpo kampani i no laik givim ol sampela mani o helpim ol liklik long taim ples balus i kamap. Bikos nau kampani i mekim mani long dispela ples balus.

Carl Sandra, Lac Bisket Co, Lac.

Aitape i no senis liklik

Dia Edita — Mi wanpela mangi bilong Aitape tasol nau mi stap wok long sip. Mi laik sapotim toktok bilong brata Max i bin kamap long Wantok namba 580.

Yes, dispela haus maket bilong Aitape em i liklik tumas. Planti ol mama i save pasim spes long ol sampela mama na tarangu ol i save go sindaun long gras na salim ol kaikai bilong ol na tu san i save hatim ol gut tru.

Mi save lukim ol olsem manmeri i givim kaikai long pik o dok bilong em long gras.

Ol taun kaunsil i mas lukluk gut na traim wokim wanpela moa haus maket bilong Aitape. Plis dispela taun bilong mipela, Aitape em wanem taim tru bai senis liklik. Aitape em i nem nating sapos yu husat manmeri yu go raun long Aitape taun bai yu yet i lukim long ai bilong yu. I luk olsem no gat ol bikman bilong mipela long Aitape long kontrolim taun.

Ol taun kaunsil na ol bikman bilong palamen na ol memba bilong provinsal gavman ating i tingim poket bilong ol tasol. Aitape em i stret na taun kaunsil i slip nating na kisim takis mani bilong ol pipel long ples.

Bilong wanem tru na ol taun kaunsil i kisim mani long get. Maski kisim mani, larim ol manmeri i go insait fri na salim ol kain kain bilong ol. Maket i no senis liklik. Hamas yia i go pinis na klostu bai wok i senis nau. Plis ol bikman traim na opim ai bilong yupela.

S.Y. Masero, MV. Moresby Chief, NCD.

Ol piksa nogut bagarapim kantri

Dia Edita — Mi laik autim wari bilong mi long Wantok Niuspepa olsem long taim ol yangpela manmeri i lukim piksa, vidio na pilai boi ol i bin kisim guptela aidia bilong bagarapim ples.

Na long taim ol i bin kisim gutpela save ol i go na brukim stua, paitim mani, repim meri, stilim ol samting

bilong ol narapela.

Sapos ol lida bilong PNG i stopim ol dispela kain samting i kam long ovas em i gutpela tru. Bai PNG i ken stap long gutpela kristen pasin.

Bipo taim ol i no bin salim ol dispela kain vidio piksa na pilai boi i kam long PNG, i bin i gat wanpela gutpela laip bilong yumi. Tasol

long taim ol i salim dispela ol samting i kam PNG i kamap olsem raskol na pipia kantri tru.

Na mi tok strong long ol lida bilong PNG long stapim vidio piksa na pilai boi long kam long PNG. Em tasol.

Yeleya Yamara, Enga Provins.

Helpim ol Ramu pipel

Dia Edita — Mi sapotim tru pas bilong Peter Manari long Wantok 27. Julai, 1985.

Peter i tok, Midel na Lowa Ramu i no gat developmen tru olsem na ol i laik bruk lusim Madang na i go bung wantaim Angoram long Is Sepik Provins. Mi i gat wankain tingting tu olsem. Dispela tupela eria i no gat developman i mas lusim Madang na i go joinim Angoram long Is Sepik.

Bikos i no gat wanpela rot i kamap long

dispela tupela eria i kam inap nau. Mi laikim provinsal Gavman i mas statim rot long Aiome na i go kamap long Nodibou. Narapela rot i mas i go long Gokto. Dispela eria i gat planti kopi, lombo na kadamon i stap isting nating. Na i no gat rot bilong salim i daun long Madang.

Mi laikim provinsal Gavman i mas baim wanpela bikpela bas o trak long karim ol kaikai olsem pis, saksak na buai i go daun long maket long Madang. Dispela bas bai karim

kaikai stat long Midel Lowa Ramu na dispela bas em bilong ron long wara Ramu.

Provinsal Gavman i mas opim ai na tingting kwik na helpim tupela eria kwiktaim.

Paul Grajuli Aropa plantesen Arawa, NSP



Coleman

continental trading co. pty. ltd.
po box 7077 boroko. ph. 252200

Kaunsil ileksen long Saten Hailans

SATEN Hailans provins bai holim jeneral ileksen long ol 14 Lokal Gavman Kaunsil long mun Oktoba. Dispela em i namba wan provins we ol pipel bai vot long ol man i kamap kaunsila bilong ol.

Provinsal Minista bilong Lokal Gavman, Mista Piko

Agwane i tok dispela lokal gavman kaunsil ileksen bai kos samting olsem K35,000 (35 tausen kina). Hap bilong dispela mani bai Provinsal Gavman i givim. Na narapela hap em ol lokal gavman kaunsil yet i givim.

Mista Agwane i tok, ol pipel i vot

long kaunsila bilong ol yet bai wankain olsem Provinsal na Nesenel Gavman ileksen. Na Saten Hailans Provins bilong em i namba wan provins long kamapim dispela kain ileksen.

Saten Hailans i gat 414 kaunsil. Na bikpela as tru long holim dispela ileksen em long helpim wok bilong ol kaunsil. Bai ol i save long ol eria ol i lukautim na hamas yia ol i wok na ol kain tok save olsem. Na bai isi long bihainim rekot olsem na long taim, mak bilong ol i pinis bai i isi long givimaut pensen mani bilong ol dispela kaunsila.

Olgeta kaunsil long Saten Hailans i stap insait long pensen mani progrem em ol lokal Gavman Kaunsil na Provinsal Gavman i save putim mani long en. Na long taim ol i pinis long wok ol i save kisim pensen mani.

Not Solomons i sot long ol tisa

OL komyuniti skul long Not Solomons Provins bai sot liklik long ol tisa neks yia bilong wanem gavman i bin givim ol inap mani long kisim 6-pela nupela tisa tasol.

Edukesen dipatmen i bin askim long 18 nupela tisa long yia bihain long wanem bai i gat moa gret wan studen i kamap long skul na tu bai i gat sampela nupela skul i op tu.

Nau yet i gat 564 (faiv handet na siksti foa) tisa olgeta i wok long tis i stap long ol komyuniti skul insait long Not Solomons Provins.

Bos bilong Edukesen dipatmen long Not Solomons i tok olsem bikos ol i sot long ol tisa long yia bihain bai ol mas painim ol narapela we bilong tisim ol studen.

Em i tok wanpela we em long bungim tupela klas aninit long wanpela tisa tasol. Em i tok tu olsem bai ol i no inap nau long kisim olgeta gret wan studen neks yia.

I bin i gat inap tisa long dispela yia.

Tasol ol i bin tingting long kisim moa tisa neks yia bikos ol i tingim ol nupela gret wan studen na ol nupela skul em bai op.

olsem 9 klok nait long Mande 9 Septemba.

Plis i mekim yet wok painimaut long dispela wari.

Plis long Not Solomons Provins i holim pasim na sasim pinis Fracis Balip, 28 kris-mas, bilong Puleroro viles, Tinputz. Plis i bilip olsem man ya i bin bagarapim wanpela meri long Tinputz long Julai 7 1985. Plis i sasim em long dispela birua.

Rausim rait plis long Madang-Gosiba

WANPELA lida bilong ol Madang pipel i tok strong i go long Provinsal na Nesenel gavman long rausim ol lain rait skwat plis i wok insait long Madang Provins.

Memba bilong Saut Ambenob, John Gosiba, i bin mekim dispela toktok bihain long ol lain rait skwat na woda plis i bin sutim indai tupela trabelman bilong Saut Ambenob eria.

Dispela man em Wap Kison bilong ples Bilbil long Madang.

Na narapela kalabus man tu, Sali Las, 19 kris-mas bilong Ouru viles i bin dai bihain long ol woda i bin sutim em long taim em i wok long ranawe long haus kalabus.

Mista Bosiba i tok ol

pipel bilong em long Saut Ambenob i gat bikpela belhevi bihain long ol plis i bin kilim dispela tupela man.

Em i tok tingting bilong bringim ol lain rait skwat long stretim hevi bilong lo na oda i gutpela. Tasol pasin ol rait skwta i mekim long dispela ol man em i no stret.

Mista Gosiba i tok ol i mas rausim ol dispela rait skwat long Madang bikos em i tok ol i rap tumas.

Na em i tok ol i mas putim wanpela nupela skwat long stretim dispela trabel bilong lo na oda long provins.

Mista Gosiba i tok Madang em i no olsem ol arapela provins we bikpela trabel i save kamap olgeta taim.

Em i tok dispela pasin bilong ol rait

skwat long karim gan na raun i mekim ol pipel long viles i pret.

Em i tok gavman i mas tingting tu long kirapim ol gutpela plen long helpim ol yangpela pipel husat i no gat wok.

Mista Gosiba i tok i luk olsem plis i wok long helpim ol man husat i gat ol samting na pawa tasol. Na ol man i no gat samting i wok long lus olgeta.

Ol nupela stem bilong PNG



BIHAIN LONG Papua Niugini i amamasim namba 10 yia bilong Indipendens long 16 Septemba, bai gat narapela bikpela de bilong amamasim 100 yia bilong postal sevis.

Dispela bikpela de bilong postal sevis bai kamap long Trinde, 9 Oktoba. Na em i taim bilong tingim ol PNG, man husat i save karim ol pas long Mosbi na krungutim "Kokoda Trel" long lek i go kamap long Popondetta long gut taim bipo.

Long Mande, 26 Ogas, Papua Niugini Filatelik Biuro i putim kamap wanpela smatpela skin-pas i gat 4-pela stem. Ol dispela stem i soim piksa bilong ol dispela PNG man bilong karim pas long Kokoda. I gat stem bilong 12 toea, 30 toea, 40 toea 60 toea wantaim hap pepa i gat dispela 4-pela stem long en. Prais bilong dispela hap pepa wantaim stem, em i K1.42.

Papua Niugini Filatelik Biuro bai salim ol dispela stem long 9 Oktoba long dispela yia. Em i de tru bilong amamasim 100 yia bilong Postal Sevis i kamap long PNG bipo i kam inap nau.

Planti manmeri husat i lukim Namba Tu Bikpela Pait i no inap lusim tingting long "Kokoda Trel" i brukim maunten eria namel long Owen Stanley Range long hap bilong Mosbi i go long Popondetta. Planti soldia bilong Japan i krungutim dispela eria namel long taim bilong pait i go long Mosbi. Tasol

lain soldia bilong Australia wantaim helpim-man bilong PNG i pait strong na stapim ol soldia bilong Japan long Kokoda maunten eria.

Sapos dispela strongpela pait long Kokoda i no kamap, em bai lain soldia bilong Japan inap krungutim Mosbi. Na bihain ol i ken krungutim Australia. Tasol tenkyu tru long paitman bilong Australia na PNG husat i mekim olgeta wok long stapim ol Japan.

Long tunde, dispela Kokoda Trel i kamap wanpela busrot, em planti manmeri i laik wokbaut na lukluk long en. Tasol planti pipel nau i ken luksave long drapelwa wok bilong ol man husat i karim pas na wokbaut long Kokoda Trel long Mosbi i go long Popondetta na kam bek.

Namel long dispela taim bipo, i gat olgeta wok bilong gavman i kamap long Mosbi tasol. Na Popondetta taun em i namba tu ples we ol narapela wok i kamap long en. Na wanpela rot bilong salim toktok long Mosbi i go long Popondetta i yusim Kokoda Trel.

Dispela wok bilong kisim pas na wokabaut long busrot i go i kam i no liklik wok. Olsem na postal sevis i bungim ol dispela hatwok. Tasol sampela liklik pos ofis i wok long kirap, bihain long Australia gavman i kirapim ol liklik gavman stesin namel Kokoda eria.

Long Desemba, 1904, gavman i bin kirapim "Mail-Runner" sevis namel long Mosbi na Kokoda, we ol man i kisim pas na wokabaut. Dispela sevis i kamap i go inap long pinis bilong Namba Tu Wol Woa. Na long Okotba, 1949, Quantas balus kampani i kirapim sevis bilong DH-84 Dragon balus i karim pas namel long Mosbi. Popondetta na Kokoda.

Planti PNG man ol i kolim "Plis Rana" i karim pas na i save krungutim planti busrot insait long kantri olsem Kokoda. Ol i wokabaut long bikbus, maunten na bungim bikpela ren o win na arapela hevi tu. Tasol ol i no wari. Ol i tingting long kisim pas i go givim long han bilong man na kisim bekim pas i go bek long Mosbi.

Nau PNG i gat balus, sip na trak na gutpela postal sevis. Tasol ol dispela nupela stem bai mekim pipel bilong tude i tingim ol man bilong bipo husat i go pas long kirapim namba wan postal sevis insait long Kokoda Trel na arapela hap tu.

● Sampela man i bin stilim K2, 100 long wanpela man bilong baim kopi na ol wokman bilong em long Goroka long Mande 9 Septemba.

Goroka plis i tok dispela samting i kamap long Sigerehi

Plis Ripot

Viles, long hap bilong Bena, Goroka, Isten Hailans Provins. Ol man i bin blokim rot na i bin holim ol naip, tamiok naston na kisim mani long dispela man bilong baim kopi.

FUJI FILM



AVAILABLE AT
OCEANIA INDENT AGENCY
Tabari Place, Boroko Ph: 25 6231 Ago St, Gordons Ph: 25 6411
Lae Ph: 42 4776



NAMBAWAN FILM LONG PNG



PROGRAM BILONG 10 INDEPENDENS SELEBRESEN



**Fraide 13 Septemba
8 am**

Ol bikpela trak em ol i bilasim pinis bai raun insait long siti (lukim mep)
Bai ol i stat na pinis long NBC Trefik Lait.

Stat — 8 am
Pinis — 11 am

3 PM

Presentesen bilong Kala long Hubert Murray Stadium.

Olgeta ka i mas stap long arere long solwara na bai i gat tripela ples bilong putim ol ka. VIP seksen, Guest seksen na Genel Pablik.

Ol pablik i mas harim tok bilong ol plisman na i gutpela sapos ol pipel i bung na go long wanpela ka o yusim ol pablik bas.

I no gat inap spes long putim ol ka olsem na No 2 oval em i bilong ol ka bilong PNG Difens Fos tasol.

SANDE 15 SEPTEMBER

Plis bihainim tok save bilong ol plisman bikos i no gat inap spes. No 2 oval bai op long ol pablik i putim ka bilong ol.

Mande 16 Septemba

Seremoni bilong apim plak long Independens Hill.

8.30 AM

Ol ka bilong ol bikman bai kam olsem long Independens Drive na Ceremonial Drive na lusim ol long Independens Hill. Na ol ka bilong ol bikman bai stap ausait long Haus Tambaran.

Ol lain em ka bilong ol i gat dispela stika 'Flag Guest' i mas kisim ka bilong ol i go olsem long Magani Crescent na go insait long hap long Palamen long get i stap klostu long Golp Kos. Ol plisman bai soim ol we long putim ol ka. Ol pablik i mas putim ka bilong ol long arere long Sir John Guise Drive o long ol arapela rot.

SEREMONI BILONG PLANIM OL DIWAI.

Bihain long seremoni bilong apim plak, ol bikman bai go dring ti long Haus Tambaran. Orait bai ol ka i kisim ol i go daun long Ceremonial Drive i go long hap bilong Constitution Park em long Independens Drive yet, we ol bai planim sampela diwai. Bikos i no gat inap spes bilong putim ol ka, ol arapela manmeri i mas wokabout i go daun long dispela hap na lusim ol ka bilong ol i stap long ples em ol i bin putim bipo.

Bihain long planim ol diwai bai ol ka i kisim ol bikman i go long hap bilong Lagani Gwauta Sports Centa long maus bilong Waigani Drive na Sir John Guise Drive.

Seremoni long dispela hap bai stat 15 minit bihain long ol bikman i kamap bikos em bai givim taim long ol arapela lain long kisim ol ka bilong ol na go kamap long hap.

HUBERT MURRAY STADIUM

Bai op long ol pablik long 10 am. Bai i no gat inap spes long putim olgeta ka olsem na mobeta ol pablik i go long bas o bung wantaim long wanpela ka. I tambu long ol pipel i putim ol ka long rot i raunim stadium.

OL PABLIK I MAS BIHAINIM TOK BILONG OL PLISMAN.

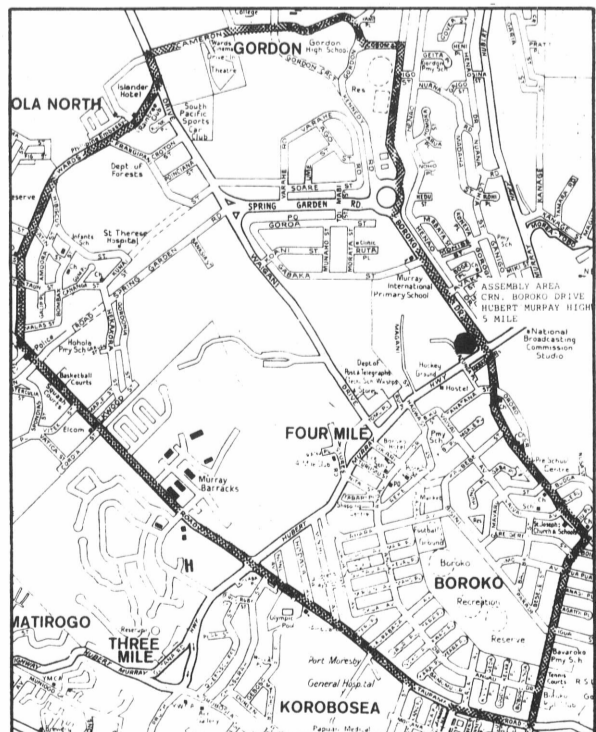



● Ol spesel botol wain long makim 10-pela yia bilong independens.

I GAT kain kain ol samting em ol kampani nabaut i kamapim long makim namba 10 yia bilong PNG i kisim independens. Na long Australia, wanpela kampani i save mekim ol kain dring olsem ol wain i redi pinis tripela kain wain em

Ol spesel dring

bai ol i salim long makim dispela bikpela de bilong PNG. Dispela Kampani Arrowfield Wine bilong Hunter Veli long Nu Saut Wels long Australia i wokim ol dispela wain na bai ol i salim long ol pipel i baim. Bikpela kampani long PNG, WR Carpenters bai salim ol dispela wain insait long PNG.

Goroka Tisa Koles kisim Helpim Mani

GOROKA TISA Koles long Isten Hailans provins i kisim sampela helpim mani i kam long Amerika. Mani ya em inap long US 15,545 i kam long Yunaitet Stet Ejensi Intenesenel Divelopmen (USAID).

Man i makim Amerika long PNG, Mista Paul F. Gardner i bin givim dispela sekmani i go long Goroka Tisa Koles long taim em i bin go long Goroka. Bai ol i yusim dispela mani long kamapim wok egrikalsa long

1.4 hekta graun insait long Goroka Tisa Koles.

Mista Gardner i tok olsem gavman bilong Amerika i amamas tasol long helpim Goroka Tisa Koles long ol wok bilong en.

Beazle - em i samting bilong PNG

MINISTA BILONG Difens long Australia gavman i tokaut long dispela wik olsem em i sori gavman bilong PNG i no laik long kisim ol fri bot bilong Pacific Patrol Boat em gavman bilong Australia bai givim long ol kantri long Pasifik.

Gavman bilong Papua Niugini i tok olsem ol bai kisim ol dispela bot sapos gavman bilong Australia i mekim sampela

senis long ples bilong wokim ol dispela bot. PNG gavman i bin tokaut long dispela samting long 2 Septemba.

Mista Beazley i tok olsem maski sapos PNG i no laikim ol dispela kain bot bai gavman bilong em i gohet yet long sainim kontrak wantaim wanpela kampani bilong Westen Australia long wokim ol dispela bot.

Em i tok olsem long taim PNG i bin lukim

ol plen bilong dispela bot long 1984 ol i bin givim tok orait long en. Na gavman bilong Australia i bin putim tok save long ol kontrak bilong wokim ol dispela kain bot.

Mista Beazley i tok tu olsem sapos PNG i no laikim ol dispela bot em i samting bilong PNG na em i no inap long egensim tingting bilong gavman bilong PNG. Em i tok tu olsem i no gat as long salim sampela tokman

bilong PNG i go long Kanbera Australia long toktok long dispela samting bikos gavman bilong Australia bai gohet na sainim kontrak bilong wokim ol dispela bot long 13 Septemba.

Tonga, Vanuatu, Solomon Ailan na Westen Samoa i tok bai ol i kisim wan wan bilong ol dispela bot. Na Fiji i tok save pinis long Australia olsem bai em i kisim 4-pela bot.

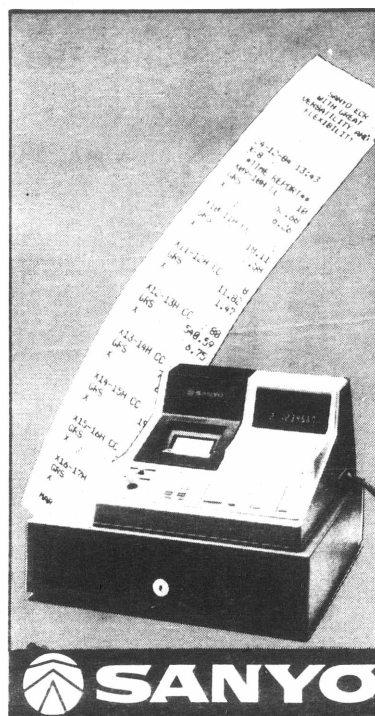

Electronic Cash Registers

SANYO FOR ACCURACY
SANYO FOR EFFICIENCY
SANYO FOR STYLE

In a range of models to suit every type of business.

"Independence Special"

Model ECR 160 2 Dept., Cash Register **K445.00**
FULL WARRANTY AFTER SALES SERVICE

Continental Trading (PNG) Pty Ltd
PO Box 7077, Boroko.
Tel: 25 2200/2425 Telex: NE 22351

10th Eniveseri

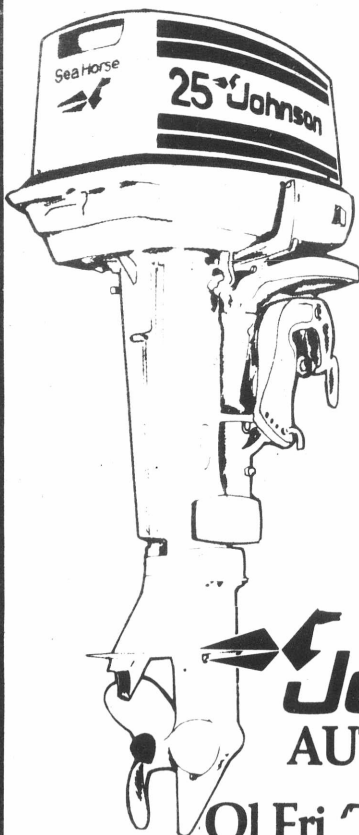

Traipela Septemba Spesols



MOTO BAIKS

HONDA

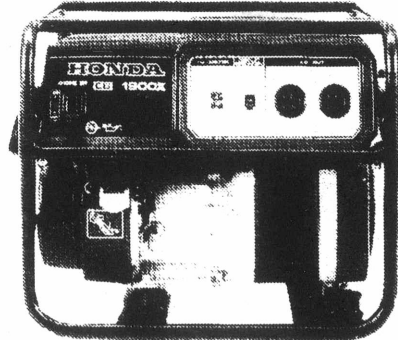

JENERETAS

Johnson
AUTBOTS

INTERNATIONAL
Stessl
BOTS

Ol Fri 'T' Siot na Hat wantaim ol wanwan samting yu baim.
SPOT BAGIN LONG PLANTI LAIN, LAE NA PORT MORESBY TASOL

HEB 3203

OL SALIM
NA SEVISIM
LONG

Steamships - MACHINERY

NA OL DILAS
LONG PNG

PORT MORESBY 25 9066 LAE 43 1753 MADANG 82 3021 RABAUL 90 1290 KIETA 95 6246

The Nations First & Finest Photofinishing Laboratory

Proudly serving the people since 1973

PNG COLOR LAB



Congratulates the Nation on its 10th Independence Anniversary



- ★ CAPTURE THE CELEBRATIONS WITH A NEW KODAK 35mm CAMERA.
— NOW ON SPECAIL!
- ★ FREE GIANT PEN WITH KODAK FILM PURCHASE (WHILE SUPPLY LASTS)
- ★ ENTER THE KODAK 'FUN TAIM' PHOTO CONTEST



MAIN LAB & FRAME SHOP
GABAKA ST., GORDON
25 4665

RETAIL SHOP
BRIAN BELL PLAZA
TURUMU ST.,
BOROKO 25 4834

MINI LAB SHOP
HUGO'S BUILDING
ANGAU DRV., BOROKO
25 8681

MINI LAB SHOP
QUEENSLAND INSURANCE BLDG.,
MUSGRAVE STREET, TOWN
21 3647

RAMU SUGA kampani i gat gutpela as long mekim bikpela amamas long dispela wik. I gat tupela yangpela menesa bilong kampani i kam bek long PNG bihain long ol i pinisim 12-wik trening kos long Ingran.

Dispela tupela menesa, Em Roy Gagau, 26 krsmas, bilong Toma viles, Rabaul, Is Nu Briten Provins na Joe Chinau, 26 krsmas, bilong Dagua, Is Sepik Provins.

Gagau em i Suprintenden bilong Harvesting na Transpot wantaim Ramu Suga

Ol tupela top man bilong Ramu Suga

kampani. Em i go kisim trening kos insait long Brighton Yunivesiti long Ingran long wok menesmen na mentenans long ol kain masin bilong wok agrikalsa.

Na em i painimaut olsem dispela trening em i narakain na gutpela moa i winim trening we em vet i kisim Basela bilong Saiens digri (BSC) long en insait long Yunivesiti bilong PNG long yia, 1980. Na em i bihainim gut taim bilong trening insait long Ingran, long

wanem i no gat dispela kain gutpela trening i kamap long PNG.

Insait long trening, em i bin go wok na kisim eksperiens wantaim sampela bikpela kampani bilong mekim kamap ol masin bilong wok agrikalsa long Windsor. Em i lukluk long Royal So long Stoneleigh na bihain em i go lukluk raun faktori bilong Massey Ferguson. Na bihain, em i iusim Ingran na i go stap long Paris, Frans long wanpela wik. Em i go lukim wok

bilong faktori ol i kolim Salon Salon de l'Agriculture.

Em na namba tu taim long Gagau i go trening long ovasis. Long yia, 1981, Ramu Suga kampani i salim em i go kisim 6-pela wik trening kos long India. Na em i skul long ol kain masin bilong kilim indai ol binatang bilong bagarapim sugaken.

Gagau i joinim Ramu Suga kampani long yia, 1980. Em i bin bungim meri bilong em, Ebo long dispela

hap. Ebo i wanpela seketeri husat i kamap pastaim long wok long dispela nupela suga projek. Ol i marit long

yia, 1982 na i gat tupela pikinini; Roy (junia), 3 krsmas na Lydia, wanpela krsimas.

Gagau i kamap

menesa long divisen bilong em long yia, 1983. Em i save sekap long ol havesta masin

i go moa long pes 13



● Joe Chinau (lepham) na Roy Gagau i toktok long wok bilong ol.

WANT TO MAKE YOUR FOOD REALLY TASTY?



Neks taim yu kukim rais, putim sampela Big Sister Curry Powder. I gat ol kain kain samting long en long mekim kaikai i swit moa yet.

WOKIM KAIKAI BILONG YU SWIT MOA

ANOTHER RECKITT & COLMAN QUALITY PRODUCT

MR KANE TASOL INAP LONG WOKIM KOKONAS BISKET OLSEM

OL SAMTING BILONG MIXIM

2 tabolspun majarin
2 tabolspun Ramu Suka
2 tispun beking pawda
2 kap sikirap kokonas
1 kiyau
1½ kap palawa

WEI BILONG WOKIM

Tanim majarin na suka i kamap olsem kirim na putim kiyau wantaim. Putim palawa, beking palawa na susu bilong kokonas i go wantaim na tanim isi tasol.



Mixim gut na putim antap long tabol na katim i go haphap.

Putim bata antap long keik tin na putim ol i go antap long en. Putim ol long aven na isi long en inap olsem 20 minit.

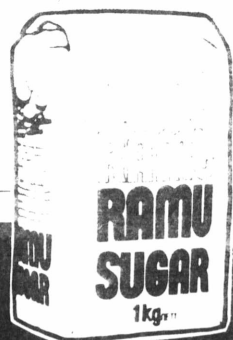
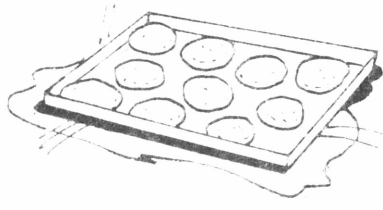

PNG SWEET ENERGY



ELCOM — TENPELA YIA BILONG OL WOK

Elcom em i wanem?

Elkom em i sotpela nem bilong nem tru bilong mipela Papua Niugini Elektrisiti Komisin. Mipela hap han bilong gavman na mipela i save mekim wok aninit long ol toktok i kam stret long gavman. Wok bilong mipela em long plenim na lukautim wok bilong kism pawa i go long olgeta hap insait long Papua Niugini em ol inap long kism pawa i go long en.

STORI BILONG MIPELA

Elkom i kamap wanpela hap nan bilong gavman long taim Palamen i tok orai long dispela samting long mun Novemba, 1961. Elkom i kamap tru long via 1963 em long taim Australia i lukautim kantri. Planti bilong ol bikpela wok bilong mipela long dispela taim em ol ovasis pipel tasol i bosim. Long dispela taim tu i no gat ol pipel bilong PNG i houm ol bikpela wok insait long Elkom. Tasol nau ol samting i senis!

BIPO LONG INDEPENDENS

Klostu long taim kantri i bin kism independens, mipela i bin wok hat tru long givim trening i go long pipel bilong Papua Niugini. Na Elkom i bin go pas long wok bilong givim trening long ol pipel bilong PNG stret long taim Elkom Trening Senta i bin kamap long Hohola. Ol lain husat i bin greduet long dispela koles i bin kism ol bikpela wok insait long Elkom long via 1970 na i go moa.

INDEPENDENS

Long independens long via 1975, mipela i kam aninit long nesenel gavman na Minista bilong Pablik Yutiliti i bin bosim mipela. Ol pipel bilong Papua Niugini yet i bin sanap insait long Bot bilong PNG tasol. Planti bilong ol bikpela wok insait long Elkom i bin go long han bilong ol pipel bilong PNG long via 1977.

SALENS NA OL SENIS

Gavman i tokim Elkom long givim lektrik pawa i go long ol pipel bilong PNG. Mipela i luksave long dispela toktok bilong gavman bikos wok bilong kirapim na lukautim wok bilong givim lektrik pawa long kantri em i bilong helpim wok developmen insait long kantri. Mipela i bilip olsem ol pipel i luksave pinis long bikpela wok lektrik pawa inap mekim long helpim ol yet na tu long kain kain wok bilong bringim gutpela sindaun i go long ol pipel long wanem hap ol i stap long en. Insait long dispela stori bai mipela i toktok long nupela samting na ol senis em mipela i bin bungim insait long dispela tenpela yia bilong independens. Na tu bai mipela i toktok long wanem samting mipela i laik mekim long ol yia i kam bihain.

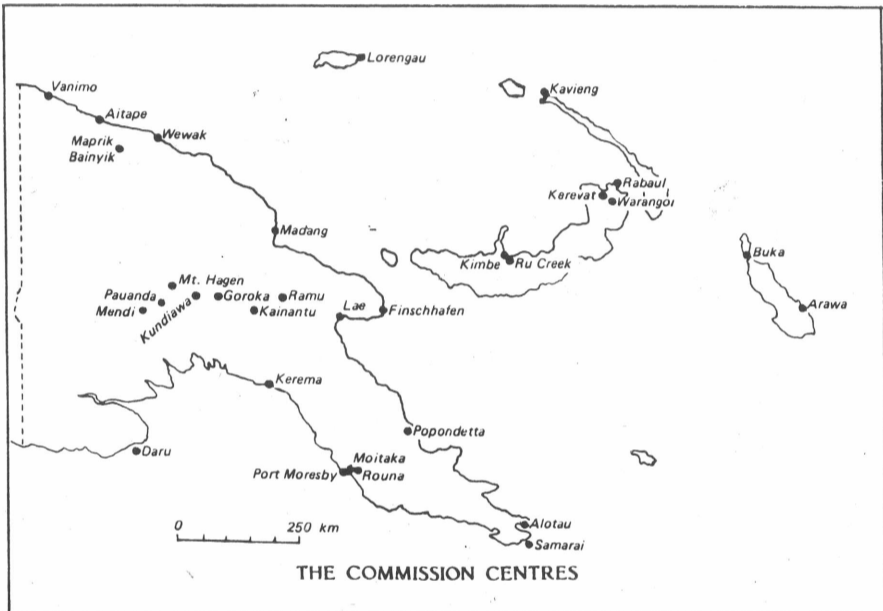

SALENS BILONG GRO YET.

Insait long dispela 10-pela yia bihain long independens i kam inap nau i bin i gat bikpela wok tru i kamap long lektrik pawa. Dispela kain wok em ol bikpela kantri tu i save hatwok long mekim na mipela tu i bin pilim dispela samting long taim ol wok bilong bringim moa lektrik pawa i go long ol ples insait long PNG i bin kamap. Olsem na mipela i amamas long tokaut olsem maski mipela i bin painim planti hevi long wok bilong mipela, mipela i win long wok bilong mipela long kism lektrik pawa i go long ol ples insait long kantri. Ol namba long hia i soim olsem mipela i gro:

- Ol senta i gat Elkom saplai 1975-1985 Senis 13.25 i go long 92%
- Ol lain i yusim lektrik pawa 26,700-43,950 io go long 65%
- Strong bilong lektrik pawa (kwh) 289,000,000-479,000,000 i go 66%
- Kos bilong ol samting K45.0 milion-K209.9 milion 366%
- Namba bilong Jenereta 80-120 i go 50%
- Ol Pawa lain 809km-3,213km i go 50%
- Ol wokman Ovasis 207-113 i go daun 45%
- Ol wokman PNG 1,553-2,201 i go antap 42%

SALENS BILONG LOKALISESEN

Wok bilong bringim pawa i go long ol ples em i wanpela wok we i mas gat ol gutpela saveman bilong holim wok. I mas i gat lektrik pawa olgeta taim long olgeta de na nait wantaim. Planti bilong PNG i bin luksave long dispela long 1975. I bin gat sampela hevi i kamap long taim bilong ol Papua Niugini pipel yet i kism ol dispela wok. Na sampela taim ol i mas wet yet inap ol i kism gut save long mekim wok bipo ol i ken tekova long husat ol ovasis man i bosim wok. Tasol nau long 1985 i gat moa pipel bilong PNG stret i mekim kain kain wok insait long Elkom. Na nau 95 pesen bilong ol wokman bilong mipela em ol Papua Niugini stret.

SALENS BILONG WOK GUT

Kamapim gutpela pawa saplai oltaim na mekim wok i ran gut oltaim em i wanpela bikpela wok bilong husat lain i bosim wok bilong ringim lektrik pawa i go long ol pipel. Em i bikpela salens tru hia long Papua Niugini bikos i gat planti maunten na ples tais na tu ol masin bilong pawa i mas kam long ovasis kantri yet. Na nau i no gat planti pipel tumas husat i save tru bilong stretim ol kain bikpela masin olsem.

I bin gat sampela hevi long dispela wok tasol mipela i winim planti ol hevi tu long mekim gutpela wok bilong bringim na lukautim gut wok bilong pawa saplai long kantri. Na long skelat ing Elkom i winim mak bilong 99.7% long wok bilong bringim pawa i go long ol pipel. Na dispela em i soim olsem ol wokman bilong Elkom bilong bipo na nau i mekim gutpela wok long lukim olsem i gat pawa saplai long olgeta de na nait long wanem wanem de mlong via.

SALENS BILONG BIHANTAIM

Mipela i amamas long ol samting mipela i mekim. Na mipela i amamas tru long ol lain bilong mipela — em ol wokman bilong Elkom — husat i bin mekim bikpela wok tru long helpim mipela na kantri bilong yumi long gro.

Mipela i amamas tasol mipela i save olsem i gat bikpela wok moa i stap yet. Mipela i mas wok strong na stretim wanem

ol hevi mipela i gat yet. Mipela i mas bekim yet wok bilong givim pawa saplai i go long ol ples longwe long taun bihain program bilong gavman long bringim ol liklik bisnis i go long ol ples.

Mipela i mas wokim Yonki. Da long hap bilong Hailans we mipela i ken bugim wara i stap long givim pawa long taim bilong san. Mipela i mas painimaut moa long wok bilong putim ol pawa lain long Lae i go long Mosbi we long taim bilong ren long wanpela hap bai ol i ken skelim pawa namel long Ramu na Rouna. Bikpela mani i save lus oltaim long baim bensin bilong ol pawa stesin olsem na mipela i mas painim rot bilong kism moa pawa i kam long ol haidro stesin. Nau pawa i kam long wara em inap long 89 pesen long ol pawa em mipela i save givim long kantri. Mipela i gat bikpela wok long givim moa save long ol wokman bilong mipela long save long wanem ol nupela samting i kamap long wok bilong ol. Yes i gat planti samting i stap yet long mekim. Dispela tenpela yia bilong independens i bin i gat ol gutpela samting na ol nupela wok na senis na ol hevi tu i bin kamap. Na mipela i ting olsem mipela inap long lukluk i go long bihaintaim na wok strong long bikpela em mipela i mas wokim narapela tenpela yia gen.

OL SAMTING I KAMAP LONG TENPELA YIA

- 1976 Ol PNG pipel stret i stap long Bot ov Komisinas. Gavana Jeneral i opim 45 MW Ramu pawa stesin.
- 1977 Komisina i stretim na kirapim ol liklik haidro pawa stesin long Simbai na Kabwum.
- 1979 wok i kirap long nupela 20 MW pawa stesin long Moitaka. Komisin i kism 12-pela pawa stesin bilong gavman insait long kantri.
- 1980 Komisin i muv i go long nupela opis bilong ol long Hohola.
- 1981 Komisin i bin wokim wanpela liklik pawa stesin long ples Sohun long Nu Ailan Provins. Na bihain ol givim i go long gavman. Strong bilong awa long dispela stesin em inap long 200 MW.
- 1982 Namba tu ges stesin long Moitaka i stat long givim pawa saplai i go long siti. Komisin i pinisim wok long pawa stesin long hap bilong Wes Nu Briten Provins. Strong bilong pawa i kam long dispela stesin em inap long 800 kw.
- 1983 12 MW Paunda Pawa stesin long hap bilong Saten Hailans Provins i stat long mekim wok bilong givim pawa.
- 10 MW Warangoi pawa stesin long hap bilong Is Nu Briten Provins i statim ol wok bilong en.
- 1984 Komisin i stretim ol computa bilong em (oli bin kism long 1981) na tu ol i bin kirapim 5-pela plen antap long 10 yia plen bilong ol. Ol i bin stretim tu ol wok bilong baim inkam takis bilong Gavman na tu long baim dividen long ol profit bilong 1984.
- 1985 Ol i stretim wok bilong kirapim wanpela 15 MW disel pawa stesin long Moitaka. Wok i stat pinis long 13.5 MW pawa stesin long Rouna No 4.

Imagine one single day without electricity!

OL PIPEL bilong PNG bai inap long harim tupela spesel program em Voice of Amerika (VOA) bai kamapim long makim namba 10 yia bilong independens bilong PNG. Dispela ol program bai kamap long Kalang Sevis bilong NBC.

Insait long dispela program Now Music USA, bai Ray McDonald bilong Wasington i toktok long independens selebren bilong PNG. Na bai em i pilai ol musik bilong Sanguma Ben em nau i raun

Spesel redio program

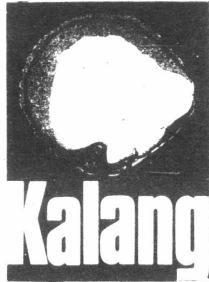

i stap long Amerika.

NBC bai brotkas long dispela program long 16 Septemba long 10 klok nait na bai ol i brokas gen long Tunde 17 Septemba long 9 klok nait.



Long Sande 15 Septemba long 10 minit pas 7 long nait. NBC bai kamapim spesel program bilong VOA em Lyn Farmer husat i bin kam raun long Mosbi bai go pas long en. Em bai toktok long ol raun bilong em insait long PNG, Fiji, Australia na Indonesia.

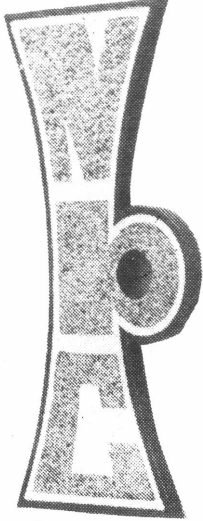

i kam long pes 11

na trakta bilong katim suga. Na em i mas lukim ol dispela havesta masin na trakta i katim 3,000 tan bilong suga insait long wan wan de na karim i go insait long faktori. Na em bai amamas, sapos olgeta masin i ron gut.

Joe Chinou i go sindaun long bikpela Intenesenel Mensmen Seminar (kibung) long Cambridge, Inglan, Booker Agriculture International (BAI) husat i menesmen

kampani bilong Ramu Suga Limitet i go pas long putim kamap dispela kibung. I gat planti yangpela menesa bilong BAI projek long planti arapela kantri long wol i kamap tu long dispela kibung.

Dispela save bilong wok menesmen i ken helpim Chinou long kalap kwik kwik long wok bilong em na kamap bikpela bosman bilong kampani.

Chinou i joinim Ramu Suga kampani long yia, 1982. Kam-

pani i promotim em i go kamap Lektrikal Suprintenden bihain long tupela yia i pinis. Na em bai kamap Lektrikal Ensinia liklik taim bihain.

Wok bilong lukautim haus pawa bilong faktori em i wanpela bilong kain bikpela samting Chinou i mas lukluk gut long en. Em i mas lukim haus pawai putim kamap 5.6 megawat bilong lektrik pawa namel long olgeta de bilong wok. Dispela mak bilong lektrik

pawa inap long go insait long kain taun olsem Madang.

Famili bilong Joe Chinou i bilong Dagua long Is Sepik Provins. Tasol mama i karim Joe long Mendi, Saten Hailans Provins. Papa bilong Joe i plisman na i wok long Mendi Plis Stesin long dispela taim.

Francesca, meri bilong Joe, i wanples yet. Ol i gat wanpela pikinini man, Solomon, husat i gat 2 krismas nau.



I gat 30 Rum Long Maun Hagen

- Em i no stap longwe long ol stua
- I gat maket i stap klostu
- I gat ples pilai i stap klostu
- I gat satelait televisen
- I gat pikap ka i sambai long ples balus

**Yu Ken Aplai Long Kisim
Spesel Pe Bilong Yusim
Motel.**

MOUNT HAGEN 52 1388

CABLES: HAPARK.
P O BOX 81, MT. HAGEN
TELEX: 52056 HGNPARK

HIGHLAND PRODUCTS LTD

PAPUA NEW GUINEAS PIONEER POULTRY PRODUCER SERVING THE NATION FOR FORTY YEARS with.



ZENAG CHICKENS, EGGS AND MILK

CONGRATULATES
PAPUA NEW GUINEA
on the occasion of the 10th Anniversary
of Independence

FOR ALL YOUR FROZEN POULTRY, FRESH EGGS and DAY OLD BROILER / LAYER PULLET REQUIREMENTS NATIONWIDE, CONTACT HIGHLANDS PRODUCTS, PNG'S LONGEST SERVING POULTRY PRODUCER AT;

PMB No. 1
ZENAG
VIA LAE PH: 44 5373 44 5375

OR LAE SALES DEPOT
PH: 42 3472 42 3900
TELEX: NE44407

Pe bilong balus sut i go antap

OL PASINDIA bilong Air Niugini balus insait long Mosbi na arapela senta insait long Papua Niugini i go het long kamautim poket tru long baim tiket bilong balus. Planti pasindia i komplem long dispela hevi. Tasol maski.

Minista bilong Sivel Eviesen, Mista William Wi na Prais Kontrolla, Mista Noreo Beangke, i tokaut long pe bilong Air Niugini balus i go antap 9 pesen moa long

olpela mak long Sande, 1 Septemba. Ol pasindia bilong Air Niusini balus i bihainim dispela nupela mak namel long Mande, 2 Septemba i kam inap nau. Na dispela nupela senis bilong pe bai stap strong i go inap long taim ol isenisim pe gen long bihain taim.

Ol hetman bilong Air Niugini, Talair na Douglas balus kampani i amamas long dispela 9 pesen senis long pe bilong balus

tiket. Long wanem ol bai sasim ol pasindia long wankain mak bilong pe. Tasol ol i bilip bai dispela senis i givim hatpela taim long ol pasindia.

Mista Beangke i tok gavman i tok orait long dispela senis, bihain long wok sekap insait long wok bisnis bilong Air Niugini na arapela balus kampani. Dispela sekap i luksave olsem ol dispela balus kampani i lusim bikpela mani moa long

pilai bilong balus insait long PNG yet namel long tupela yia. Olsem na i gat gupela as long mekim kamap dispela senis bilong pe.

Em i tok dispela senis bai helpim ol balus kampani long ranim wokbisnis ol igo yet na givim gupela senis long ol pasindia insait long dispela kantri. Tasol em bai mekim wok sekap yet na traim long stapim pasin bilong apim pe bilong balus i go antap long bikpela mak. Em i laikim bai pe i mas senis isi isi namel long wan wan taim. Na maski long pasin bilong apim pe i go antap kwiktaim tru namel long olgeta tri mun o 6 mun.

Hia em i nupela singel pe bilong balus namel long Mosbi na arapela senta: Mosbi-Lae K76 (pe i go antap K6 moa); Madang K108 (K9); Goroka K101 (K13); Hagen K110 (K9); Rabaul K156 (K12); Kieta K189 (K15); Kavieng K196 (K16); Wewak K172 (K14); Manus K172 (K14); Gurney (Alotau) K85 (K7); Popondetta K49 (4) na Hoskins K117 (K9).

Long las wik Trinde, 4 Septemba, Nesenel Gavman i givim tok orait gen long Talair i

resis wantaim Air Niugini long plai bilong balus insait long PNG. Dispela resis bai kirap long Fraide, 1 Novemba, na i go inap long 5-pela mun.

Mista Wi i givim dispela tok orait long Talair husat i bikpela namba tri-level balus kampani insait long PNG. Em i tok dispela i no min olsem bai Talair i ken baim ol nupela bikpela balus long resis wantaim Air Niugini. Nogat. Talair bai go het long yusim ol dispela liklik balus em i yusim nau.

Em i tok kliia tu olsem ol dispela balus kampani mas tingting long givim smatpela sevis long ol pasindia bilong en. Na maski

long mekim ol pasindia i hatwok long sevim ol.

Namba wan papa na mensing dairekta bilong Talair kampani, Mista Dennis Buchanan i amamas long gavman i larim kampani bilong em i resis wantaim Air Niugini insait long dispela wok traim namel long 5-pela mun. Sapos dispela wok traim i pulim gupela mani, bai kampani bilong em i baim tupela nupela Des 8 na tupela Brasilia balus.

Mista Buchanan i bilip bai Mista Wi i ken orait em long baim ol dispela nupela balus. Sapos Mista Wi i tok yes, bai Talair i ken baim Des 8 o Brasilia balus long Me na

Septemba, neks yia. Na Talair i tingting tu long baim Ep-27 balus na wanpela bikpela balus long Ingran.

Mista Wi i tokaut tu olsem em i laik larim narapela namba tri-level balus kampani i resis gen wantaim Talair insait long PNG. Tasol dispela tingting i no min bai em i larim ol balus kampani bilong ovasis i kam resis long PNG.

Sapos dispela rot bilong larim tupela o tripela balus kampani i resis long karim pasindia namel long ol senta long PNG i kamap, bai pipel i kisim gupela sevis. Ol pasindia i ken pilai long balus ol i gat laik long en. Na ol i no inap westim taim wantaim "sambai tiket," long wanpela balus kampani tasol.

Rot bilong salim PNG timba

NESENEL GAVMAN i makim Fores Indastris Kaunsil em bai wanpela lain tasol long makim gavman o kantri long mekim wok bilong painim maket long ovasis kantri long salim timba bilong PNG.

Fores Indastris Kaunsil i amamas long dispela na i stat pinis nau long stretim oi rot em bai mekim dispela wok Fores Indastris Kaunsil i stap aninit long Dipatmen bilong Fores.

Praim Minista, Mista Somare i tok dispela maket eijensi

bai i kamap olsem "Stet Maketing Ajen" (SMA). Na dispela lain bai salim ol timba bilong PNG i go long ol ovasis kantri husat i laikim timba. Na nau bai PNG i no inap long wok wantaim ol namel man long salim timba.

Timba bilong PNG kampani namba 3 long ol samting em PNG i save salim i go long ol narapela kantri. Namba wan em kopa na gol namba 2, em kopi, na timba i namba 3.

Olsem na gavman i makim dispela lain long wok gut na salim

planti gupela timba bilong kantri stret.

Gavman i wokim dispela rot bihain long Fores Minista, Mista Lucas Waka i bin givim ripot i go long kabinet olsem bipo ol wan wan grup o kampani i save tra hat tru long baim timba, na salim i go long arapela kantri.

Na ol i bin painim hat tru. Tasol rot i op long PNG i ken kisim gupela prais o mani long ranim gut wok bilong salim timba na Fores Indastris Kaunsil o Stet Maketing Ajen bai ranim olgeta wok.

i kam long pes 3

siesen i ken i go kisim nau long seketeri na Mista Absolom.

Dispela stail kala, kala stika tu i makim 10 yia Independens amamas bilong Asosiesen tu. Olgeta memba bilong Asosiesen mas kisim na putim long bas bilong ol raun long taun long dispela bikpela bung wantaim taim.

Ol i gat 300 stika olgeta em ol isalim sam o mak i go long Nu



Silan long prinim. Na i kos K80 olgeta. PNG Printing i bin helpim

Asosiesen long salim i go na stretim olgeta rot.

KRAFT

Congratulations on 10 years of Independence

are proud of their contribution to the healthy development of the people of Papua New Guinea



Distributed in Papua New Guinea by: **CONSUMER SALES & MARKETING**

Isten Hailans redi long salim ol kumu

ISTEN Hailans Provins i promis long saplaim kumu long olgeta pipel bilong PNG. Ol growa i laikim ol kampani long baim kumu i mas promis olsem ol bai baim ol dispela kumu bilong ol.

Dispela toktok i kamap long ol growa na ol lida bilong Isten Hailans

bihain long nesanel gavman i tokaut olsem. long Novemba (dispela yia) bai ol i stapim ol kampani long kantri i oda long sampela kain kumu long ovasis kantri.

Ol pipel bilong Goroka i tok olsem long Hailans, pipel i ken groim kain kain kumu. Dispela ol kumu i ken kisim ples bilong ol kumu em planti bikpela stua i save oda i kam long narapela kantri.

Na tu, ol i bilip olsem bisnis long egrikalsa bai strong long PNG sapos ol kampani i baim kumu long Hailans.

Ol man husat i gat kumu gaden nau long Goroka na ol yut grup i bin tok olsem ol i save painim hat long salim ol kumu bilong ol nau bikos nogat kampani i laik baim long ol.

Primia bilong Saten Hailans, Mista Youngtine

Koromba i tok tu olsem provins bilong em i ken groim kain kain kumu, tasol gavman i mas painim rot bilong ol pipel bilong em long salim ol dispela kumu.

Ekting Seketeri bilong Enga, Mista Luke Kembol i tokaut olsem provinsal gavman i bin statim pinis program bilong helpim ol kumu growa i kamapim planti kumu. Dispela wok em go het

nau wantaim rural development program bilong ol.

Olgeta Hailans provinsal gavman i gat wankain bikpela wari. Ol i save long bipo yet olsem, planti kumu bilong ol growa bilong ol i save sting nating bikos no gat kampani i save baim. Ol lida bilong ol Hailans i no laik lukim dispela kain pasin i kamapgen, bihain long nesanel gayman i putim tambu long ol kampani long baim kumu long narapela kantri.

Wanpela bikpela kampani bilong maketim ol kumu long Goroka, Hoveku Pty Ltd i tok tenkyu long Stimsip Kampani long sata long ol balus long kism ol kumu long Goroka na Hagen i go long Lae.

Jeneral menesa bilong Hoveku Pty Ltd, Mista James Watson i tok ol kampani olsem Burns Philp tu i mas tram long helpim ol kumu growa na sata long balus long kism kumu i go long ol arapela taun tu.

Minista bilong Pramerit Industri, Mista Rabbie Namaliu i tok olsem dipatmen bilong em bai traim long stretim rot namel long ol growa na kampani bilong baim ol kumu bai dispela bisnis i ken ran gut.

Em i tok olsem, ol kampani i painim aut



olsem em i isi long baim ol kumu long ovasis kantri bikos ol i gat gutpela sistem long transpot, lukautim gut kumu, salim gutpela kumu, na ol i gat ol bikpela bokis ais bilong holim ol kumu long planti wik bai ol i no inap bagarap. Na tu pe i no bikpela tumas.

Mista Namaliu i tok, ol bikpela kampani i tokaut olsem ol lokal kumu growa i no inap long saplaim gutpela kumu. Olsem na ol i painim gutpela long oda long ovasis. Tasol em i bilip ol growa i ken kamapim gutpela kumu long taim ol i gat bikpela maket bilong salim kumu bilong ol.

Long Novemba, 1985, PNG gavman bai tamu long ol kain kumu olsem long kam insait long kantri. Em: kapis, patete, kukamba, kapsikum, lombo, pampkin, maro, bin, tomato, spring anian,

avokado, moli, grepfrut, peas, melen, mango, popo, banana, painapel, pesenfrut, guava, swit patete, junja (kawawar), egplen, okra, silvabit, kon, redis, choko na rhubarb, karot, brokoli, kauliplawa, galik, letes na stroberi.

Gavman bai tambu long ol dispela kumu long go long ol taun olsem: Lae, Madang, Wewak, Alotau na Popondeta. Tasol Mosbi, Kavieng, Rabaul, Lorengau na Kieta bai kisim yet sampela ol dispela kumu long arapela kantri.

Ol kampani i gat wanpela bikpela wari olsem pe bilong transpot bilong kism ol dispela kumu long Hailans taun i go long ol arapela taun i antap tumas tasol Mista Namaliu i tok pinis olsem wanpela nupela bot bai kamap insait long dipatmen bilong em long lukluk na stretim ol dispela kain wari.





General Foods USA





Proud to be associated with the people of Papua New Guinea

Congratulations on your 10th Birthday

Distributed in Papua New Guinea by: CONSUMER SALES & MARKETING

COME ALIVE, COME AND DRIVE WITH THE GOOD GUYS NISSAN PATROL Pikap Trak

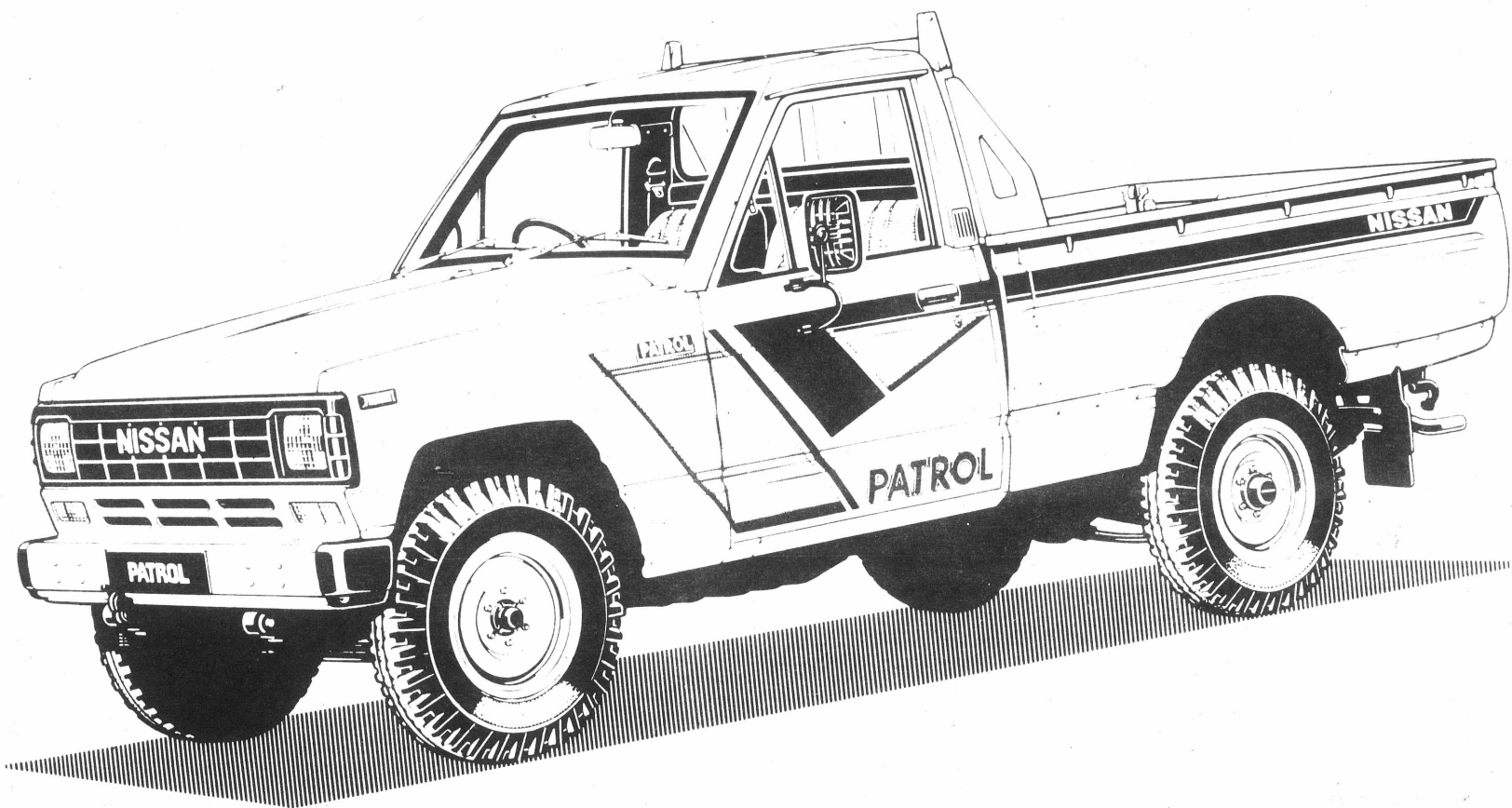

Available from:

"The good Guys"



BOROKO MOTORS	25 5255	— Port Moresby
BOROKO MOTORS	42 1145	— Lae
BOROKO MOTORS	92 2777	— Rabaul
BOROKO MOTORS	82 2433	— Madang
BOROKO MOTORS	52 1433	— Mt Hagen
ARAWA MOTORS PTY LTD	95 1566	— Arawa
HIGATURU MOTORS PTY LTD	29 7175	— Popondetta
PROVINCIAL AGENCIES PTY LTD	94 2131	— Kavieng
TORO MOTORS PTY LTD	57 4059	— Wapenamanda
MILNE BAY ENTERPRISES PTY LTD	61 1167	— Alotau

Em i gat bikpela pawa bilong ran strong. Em bai krungutim graun strong. I gat pawa long karim ol draipela kago. Em i nambawan smatpela trak. Nissan Patrol Pikap Trak i gat ol dispela samting na yu ken lukim long smatpela wok bilong en.

Dispela strongpela na smatpela 4-Wil Draiv pikap trak i no inap mekim yu wari tumas long olgeta hap yu go long en. Plai go daun long haiwe rot. Krungutim graun malumalu na liklik rot nabaut long maunten. Krungutim ol eria bilong fam gaden na banis bulmakau. Brukim ol wara i gat 600 milimita daun. Ol kain bikpela wok yu laik wokim, em dispela Pikap Trak bai mekim dispela wok i kamap isi tru.

NISSAN



Going Places

High School at home - COES helps
you with your studies



COLLEGE of EXTERNAL STUDIES

COLLEGE of EXTERNAL STUDIES

NUMBER 161

Navigating the Pacific

The people of the Pacific have navigated the ocean for thousands of years using the stars.

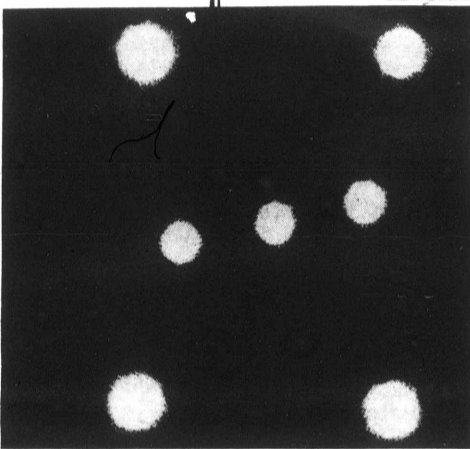

ORION'S BELT is composed
of the three stars in a row

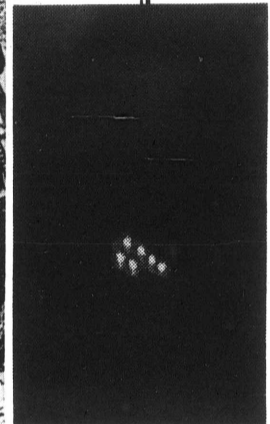
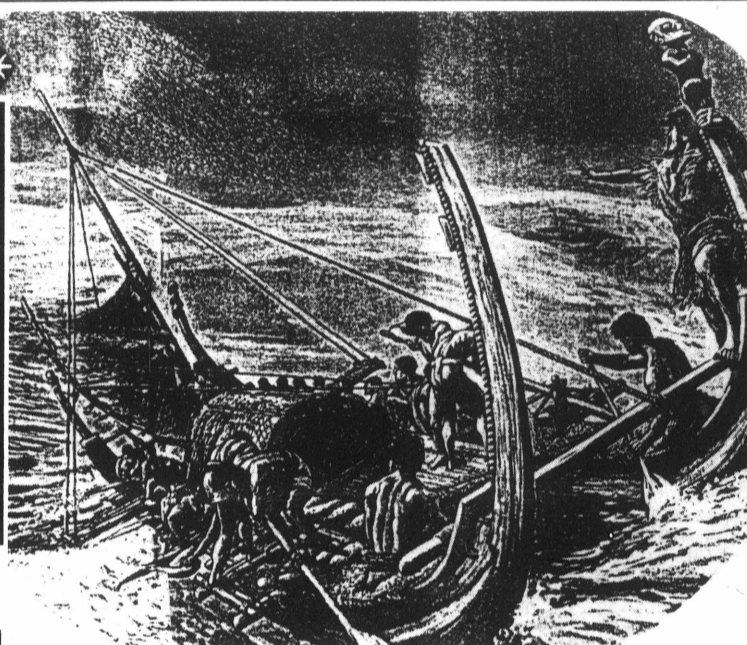

PLEIADES A cluster of about 200
stars formed about 60 million years ago.
Often called the Seven Sister, though
only six are visible to the naked eye.

They note the places on the horizon where stars appear and disappear and have learnt the seasonal position of the sun and moon in relation to them. They know which islands lie under different stars.

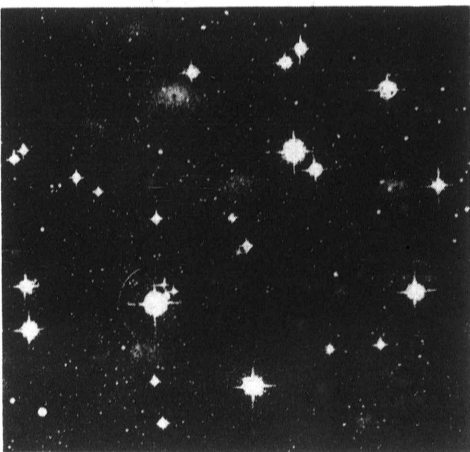

PLEIADES as seen through a telescope

Most of the people of the Pacific did not have a system of writing until recently. Therefore the navigators made up songs to teach the way to different islands. Here is one telling how to get from Bora Bora to Hawaii.

Wait for the west wind, wait for the west wind!
Then sail to Nuku Hiva of the dark bays
To find the constant star.
Hold to it, hold to it,
Though the eyes grow dim with heat.
Hold to it, hold to it,
Till wild Ta'aroa sends the winds.
Then speed to the clouds where Pere waits.
Watch for her flames, the flames of Pere,
Till great Tane brings the land,
Brings Havaiki-of-the-North,
Sleeping beneath the Little Eyes.

Nuku Hiva lies under the stars known as Orion's Belt. The "Constant Star" means the north star which does not move in the sky. The flames of Pere refers to the volcano in Hawaii. The Little Eyes is the name given to the six little stars known as the Pleiades.

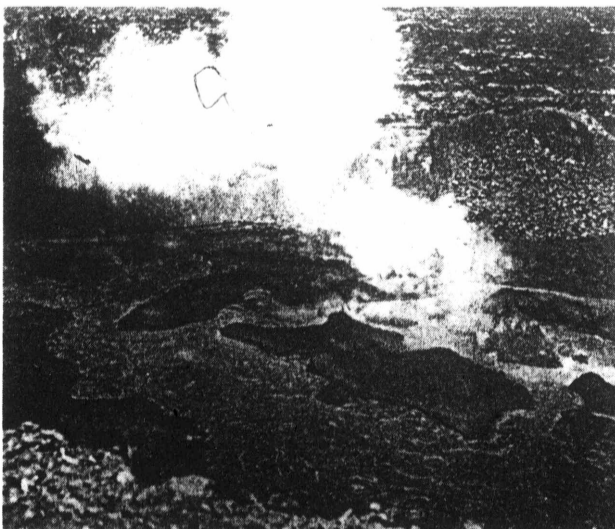

Madame Pele — Goddess of volcanoes
(in Bora Bora Pele is called Peré)

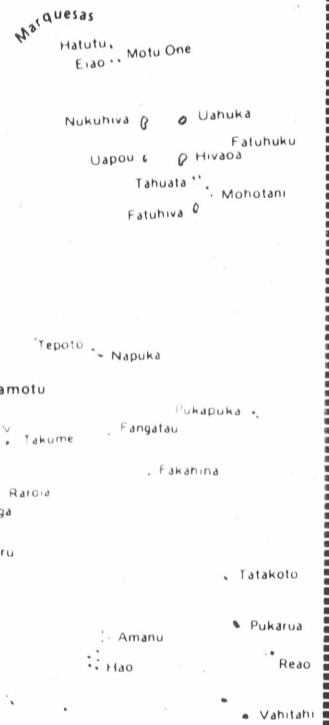

The ancient Hawaiians believed that Madame Pele, the Goddess of Volcanoes, manifested her presence at each eruption. Some Hawaiians believed the rock formation on the left was a symbolic profile of the goddess exposed by the eruption of Kilauea crater that occurred in 1952.

It took many years to train a navigator. Experienced navigators would choose bright children and begin training them on the beach. The children would sit in a model boat surrounded by patterns of rocks and stones, indicating currents and ocean swells. They had to learn and use the many star paths in the night sky. Today few children can spare the time from school to learn the old skills of navigation.



PAPUA NEW GUINEA DEPARTMENT OF EDUCATION

UNIT V

LOST OR DESTROYED

The Education Department is hereby notified to state that the following Grade 10 Certificates of Attainment have been issued to the holders thereof since the date of such a certificate after the date thereof.

HERE TAITA	BUSU HIGH SCHOOL	1972	02/01/85	NAIMINI ROSE	YARAPOS HIGH SCHOOL	1979	22/02/85
PAKE BEN	KIMBE HIGH SCHOOL	1980	02/01/85	KALI API	IAROWARI HIGH SCHOOL	1975	22/02/85
ASIME JABI	KARKAR HIGH SCHOOL	1983	02/01/85	ALTER THOMAS	MALABUNGA HIGH SCHOOL	1978	22/02/85
WAMBENA BENSON	RABAU HIGH SCHOOL	1980	02/01/85	BEGIRO JOSEPH	BADIHAGWA HIGH SCHOOL	1983	22/02/85
ARISA JOHN	SOGERI HIGH SCHOOL	1969	02/01/85	SARWOM FELIX	DELA SALLE HIGH SCHOOL	1978	22/02/85
BIRU JAMES	PORT MORESBY TECH COLL	1976	02/01/85	HOTO CHARLIE	KILA KILA HIGH SCHOOL	1975	22/02/85
NORMAN VALERY	BOISEN HIGH SCHOOL	1983	02/01/85	LOVOA MARUMORI	MALALAU HIGH SCHOOL	1984	22/02/85
OLO SIWAKA	MT HAGEN TECH COLLEGE	1977	02/01/85	MOEA BORA	PORT MORESBY TECH. COLL	1975	22/02/85
LAWRENCE PAUL	BUGANDI HIGH SCHOOL	1977	02/01/85	BUDA MATTHEW	DELA SALLE HIGH SCHOOL	1974	22/02/85
WAUYARI KINI	BENABENA HIGH SCHOOL	1983	02/01/85	YANINEN FERZETT	YANGORU HIGH SCHOOL	1981	22/02/85
KANE NULAI	KEROWAGI HIGH SCHOOL	1983	11/01/85	KANIOI ANASTASIA	ASITAVI HIGH SCHOOL	1981	22/02/85
ALON YAKARING	PAUSA HIGH SCHOOL	1980	11/01/85	KETAP ARNOLD	FATIMA HIGH SCHOOL	1971	22/02/85
HILAI HUA	IHU HIGH SCHOOL	1983	11/01/85	BONO AWOI	KUPIANO HIGH SCHOOL	1981	22/02/85
FEGONI WAFO	GOROKA HIGH SCHOOL	1981	11/01/85	ULKA MARY	KEROWAGI HIGH SCHOOL	1981	22/02/85
JURUMBARI ANDREW	MARTYR'S HIGH SCHOOL	1983	11/01/85	NAIMINI ROSE	YARAPOS HIGH SCHOOL	1979	25/02/85
GOMA SIUNE	TUSBAB HIGH SCHOOL	1970	11/01/85	KALI API	IAROWARI HIGH SCHOOL	1975	25/02/85
TAE RIGOLO	KWIKILA HIGH SCHOOL	1977	11/01/85	ALTER THOMAS	MALABUNGA HIGH SCHOOL	1978	25/02/85
LAIAM MATTHEW	DE LA SALLE HIGH SCHOOL	1976	11/01/85	BEGIRO JOSEPH	BADIHAGWA HIGH SCHOOL	1983	25/02/85
SINIK ROBERT	BUGANDI HIGH SCHOOL	1977	11/01/85	SARWOM FELIX	DE LA SALLE HIGH SCHOOL	1978	25/02/85
DERA ANTON FAREN	MALALA HIGH SCHOOL	1976	11/01/85	HOTO CHARLIE	KILA KILA HIGH SCHOOL	1975	25/02/85
KAPILO ROBERT	ST.FIDELIS HIGH SCHOOL	1973	11/01/85	LOVOA MARUMORI	MALALAU HIGH SCHOOL	1984	25/02/85
TALIU BOBO	KOKOPO HIGH SCHOOL	1982	11/01/85	MOEA BORA	PORT MORESBY TECHNICAL	1975	25/02/85
HARO KAIRI	KILA KILA H.S.	1973	16/01/85	BUDA MATTHEW	DE LA SALLE HIGH SCHOOL	1974	25/02/85
GWITYEAKWIYE SOLOMON	BUGANDI H.S.	1974	16/01/85	YANINEN FERZETT	YANGORU HIGH SCHOOL	1981	25/02/85
WAMUGL KORARA	KEROWAGI HIGH SCHOOL	1972	22/01/85	WANINARA KALAMLAM	BOISEN HIGH SCHOOL	1978	25/02/85
KUMUNO PETER	ROSARY HIGH SCHOOL	1979	22/01/85	LIKIO CONDRAD	VUVU HIGH SCHOOL	1977	25/02/85
RATSI ALPHONSE	BUN HIGH SCHOOL	1980	22/01/85	JACK BAGAHU	KILA KILA HIGH SCHOOL	1983	25/02/85
BOTI GIVASON	IAROWARI HIGH SCHOOL	1980	22/01/85	KANIOI ANASTASIA	ASITAVI HIGH SCHOOL	1981	25/02/85
JAMES MAI	KILAKILA HIGH SCHOOL	1978	22/01/85	KETAP ARNOLD	FATIMA HIGH SCHOOL	1971	25/02/85
KEVIN RHONDAH	GORDON HIGH SCHOOL	1981	22/01/85	BONO AWOI	KUPIANO HIGH SCHOOL	1981	25/02/85
KUAMIN A. JOLAM	RABAU HIGH SCHOOL	1981	22/01/85	LONGERI NOEL	PALMALMAL HIGH SCHOOL	1982	28/02/85
SUNA JOSEPH	ROSARY HIGH SCHOOL	1981	22/01/85	JU PETER	FATIMA HIGH SCHOOL	1980	28/02/85
AMOS SHIRLEY	BOISEN HIGH SCHOOL	1983	22/01/85	NENDEKOT LINUS	MAPIRK HIGH SCHOOL	1977	28/02/85
PAIMURU MUKA	IAROWARI HIGH SCHOOL	1977	22/01/85	DAVANA PALU	KWIKILA HIGH SCHOOL	1981	28/02/85
GAPI EDDY	BRANDI HIGH SCHOOL	1979	22/01/85	HUB JOSEPH KAUKOI	MALALA HIGH SCHOOL	1975	28/02/85
OFE MERO	KWIKILA HIGH SCHOOL	1974	22/01/85	KIAGE PETER	GOROKA TECHNICAL COLLEGE	1976	13/03/85
OPA PIUS	HAGEN PARK HIGH SCHOOL	1978	22/01/85	HAEMBO RODRICK	POPONDETTA HIGH SCHOOL	1983	13/03/85
TURE ANDREW	MALAGUNA TECH.COLLEGE	1975	22/01/85	BONIT ELIES	MALABUNGA HIGH SCHOOL	1974	13/03/85
KAMO CAMILLO	TAPINI HIGH SCHOOL	1984	22/01/85	MISIKALI NEAKSON	PAUSA HIGH SCHOOL	1971	13/03/85
NIMIGORA FINE	BADIHAGWA HIGH SCHOOL	1984	22/01/85	PAINAP KENEDY	PALMALMAL HIGH SCHOOL	1979	13/03/85
MORI JOHN	BUSU HIGH SCHOOL	1981	22/01/85	GOLIATH HELEN	GEORGE BROWN HIGH SCHOOL	1978	13/03/85
LEPILI PEPA	IALIBU HIGH SCHOOL	1981	22/01/85	NARING KUSS	KARKAR HIGH SCHOOL	1981	13/03/85
ERI HELEN	MARIANVILLE HIGH SCHOOL	1980	22/01/85	MAIMA BAIRE	GUMINE HIGH SCHOOL	1983	13/03/85
TOBIA THOMAS	IAROWARI HIGH SCHOOL	1980	22/01/85	MAR JOHN	LAIAGAM HIGH SCHOOL	1983	13/03/85
SIWI WAUGLA	KEROWAGI HIGH SCHOOL	1977	22/01/85	KINI RAVU	DE LA SALLE HIGH SCHOOL	1979	13/03/85
RESANIMO GASOWO	GOROKA HIGH SCHOOL	1977	22/01/85	MAHIRO LARI	KILA KILA HIGH SCHOOL	1970	13/03/85
TORO JIMMY	PORT MORESBY TECH. COLL	1976	22/01/85	NONE	NONE	1909	13/03/85
DGN POKON	ASAROKA HIGH SCHOOL	1969	22/01/85	MAPAIA GEORGE	DE LA SALLE HIGH SCHOOL	1969	18/03/85
POLOS BAPSI	UTU HIGH SCHOOL	1979	30/01/85	RABU ROBERT	KEREMA HIGH SCHOOL	1982	18/03/85
DUM ANNA	NOTRE DAME HIGH SCHOOL	1983	30/01/85	MANU LEVA	KWIKILA HIGH SCHOOL	1982	18/03/85
KINI RONNIE	KWIKILA HIGH SCHOOL	1983	30/01/85	ORARI HAYWARD	MARTYRS MEMORIAL HIGH	1983	18/03/85
SILIWEN GABRIEL	BUSU HIGH SCHOOL	1975	30/01/85	MUTU PETER	MALAGUNA TECHNICAL COLL	1976	18/03/85
WAPALIN JOHN	WABAG HIGH SCHOOL	1978	30/01/85	TONGIA BOE	LAE HIGH SCHOOL	1977	18/03/85
TURPAT DAVID	BOISEN HIGH SCHOOL	1982	30/01/85	TOPOT SANAO	BUGANDI HIGH SCHOOL	1978	18/03/85
MEK MARTIN	UTU HIGH SCHOOL	1981	30/01/85	TORU JANET	O.L.S.H. HIGH SCHOOL	1981	26/03/85
LA-ABE ANNA	MALABUNGA HIGH SCHOOL	1974	30/01/85	LEVONGO NIRIPO	MENDI HIGH SCHOOL	1975	26/03/85
AVOA DESMOND	DE LA SALLE HIGH SCHOOL	1974	30/01/85	SIWI KERENGA	KEROWAGI HIGH SCHOOL	1980	26/03/85
TIKALOM LIBORIUS	RABAU HIGH SCHOOL	1976	30/01/85	KARARA NOEL	KILA KILA HIGH SCHOOL	1979	26/03/85
KULA BILAGAGA	MALABUNGA HIGH SCHOOL	1977	30/01/85	VARPIN VINCENT	ST.MARY'S H.S. VUVU	1979	26/03/85
YAVIG YERITINE	DREGERHAFEN HIGH SCHOOL	1981	30/01/85	RALAI VALI	BADIHAGWA HIGH SCHOOL	1979	26/03/85
SARI PATRICIA	MALALAU HIGH SCHOOL	1981	30/01/85	TUVAO DUANA	IAROWARI HIGH SCHOOL	1983	26/03/85
KUBIN ROSEMARY	BOISEN HIGH SCHOOL	1983	30/01/85	KAMANE LAKI	IAROWARI HIGH SCHOOL	1982	26/03/85
KILA RUTH	KWIKILA HIGH SCHOOL	1978	30/01/85	VIVIDUBU KIVERI	KEREMA HIGH SCHOOL	1981	26/03/85
HARIHU NOEL	MENDI HIGH SCHOOL	1982	30/01/85	HAIHAVU AVEA	KEREMA HIGH SCHOOL	1977	26/03/85
MERAWO MAROME	CHUAVE HIGH SCHOOL	1981	30/01/85	SELAN LUKE	PAPITALAI HIGH SCHOOL	1977	26/03/85
KOND KOMBATTI	FATIMA HIGH SCHOOL	1978	06/02/85	KOMBUKUN BORLU	LAE TECH. COLLEGE	1976	26/03/85
POKANA LESLEE	GORDON HIGH SCHOOL	1980	06/02/85	PAPO ANDREW	ST.MARY'S H.S. VUVU	1976	26/03/85
KILORI LARI	MARIANVILLE HIGH SCHOOL	1982	06/02/85	KILA KILA	KWIKILA HIGH SCHOOL	1980	26/03/85
HIHA LAVURU	MALALAU HIGH SCHOOL	1983	06/02/85	LAMB KURAS	WABAG HIGH SCHOOL	1979	26/03/85
PHILIP MELA	TARI HIGH SCHOOL	1983	06/02/85	ILA ILA	KWIKILA HIGH SCHOOL	1970	26/03/85
NOUWE WESLEY	UTU HIGH SCHOOL	1983	06/02/85	AULO ROCKSY	ASAROKA HIGH SCHOOL	1984	09/04/85
TEMEVIVIEN GALLY	MADINA HIGH SCHOOL	1976	06/02/85	KAMA KAWAGE	KITIP HIGH SCHOOL	1982	09/04/85
PEPENA GABRIEL	MT HAGEN TECH COLLEGE	1978	12/02/85	MWAWESI ADRIAN	HAGITA HIGH SCHOOL	1973	09/04/85
SIPAU ELIJAH	BOISEN HIGH SCHOOL	1977	12/02/85	TANI KALAKI	WESLEY HIGH SCHOOL	1976	09/04/85
AMBIA EDWIN	BUSU HIGH SCHOOL	1981	12/02/85	HENI RANO	BADIHAGWA HIGH SCHOOL	1976	09/04/85
MAGE FIJOUKE	BENA BENA HIGH SCHOOL	1980	12/02/85	BOPA KAMTAI	CHUAVE HIGH SCHOOL	1983	09/04/85
AREA SIMON	IHU HIGH SCHOOL	1983	12/02/85	POUTA ANNA	KEREMA HIGH SCHOOL	1982	09/04/85
KIARU PAUA	IHU HIGH SCHOOL	1983	12/02/85	YANDAWA BRIAN	TARI HIGH SCHOOL	1979	09/04/85
RAKA MAURI	KILA KILA HIGH SCHOOL	1983	12/02/85	SUNGAN TUANZING	BUGANDI HIGH SCHOOL	1981	09/04/85
OVAKORA GABRIEL	KEREMA HIGH SCHOOL	1978	12/02/85	TALIO THOMAS	DIVINE WORD HIGH SCHOOL	1981	09/04/85
SANGI CASPAR	MALALA HIGH SCHOOL	1978	12/02/85	MAMBI WALEA	IALIBU HIGH SCHOOL	1978	09/04/85
ABDUL GEORGE	DELA SALLE HIGH SCHOOL	1977	12/02/85	SIMINA KAMA	CHUAVE HIGH SCHOOL	1978	09/04/85
GIMA TAU	GORDON HIGH SCHOOL	1977	12/02/85	TUBU MARGARET	O.L.S.H. HIGH SCHOOL	1978	09/04/85
AISOLY MUKO	HOSKINS HIGH SCHOOL	1983	12/02/85	GELUA MINIM	GOROKA TECHNICAL COLLEGE	1977	09/04/85
HAVA HEKAHU	KEREMA HIGH SCHOOL	1982	12/02/85	TEK STEPHEN	MALAGUNA TECH. COLLEGE	1977	09/04/85
HAIU NAVARAI	KEREMA HIGH SCHOOL	1971	12/02/85	LOVI KARAU	KILA KILA HIGH SCHOOL	1973	09/04/85
API KIWI	BADIHAGWA HIGH SCHOOL	1979	15/02/85	KUNI MANE	MENDI HIGH SCHOOL	1976	09/04/85
KOROA KOROA	KWIKILA HIGH SCHOOL	1983	15/02/85	WEWI HEDWIG PONING	NOTRE DAME HIGH SCHOOL	1976	09/04/85
TOMTILI LUKE	MONGOP HIGH SCHOOL	1977	15/02/85	WARO HEHURE	GOROKA HIGH SCHOOL	1977	16/04/85
KAR GETRUDE	KONDIU HIGH SCHOOL	1977	15/02/85	LAVIYONG MERENGU	ASAROKA HIGH SCHOOL	1977	16/04/85
KURKUR PAUL	DIVINE WORD HIGH SCHOOL	1979	15/02/85	FRON DIOP	MALABUNGA HIGH SCHOOL	1979	16/04/85
LUKE SALOMI	MARIANVILLE HIGH SCHOOL	1981	15/02/85	PAGAVE RENAGI	KWIKILA HIGH SCHOOL	1980	16/04/85
KISO NISO	PAUSA HIGH SCHOOL	1981	15/02/85	LEO PO	WABAG HIGH SCHOOL	1982	16/04/85
LEKKER LESTER	KUPIANO HIGH SCHOOL	1979	15/02/85	GABAR MIKEL	TUSBAB HIGH SCHOOL	1975	16/04/85
VALI RAYMOND	BADIHAGWA HIGH SCHOOL	1976	15/02/85	AGLUM PETER	KONDIU HIGH SCHOOL	1973	16/04/85
MICHAEL CLEMENT	LAIAGAM HIGH SCHOOL	1980	15/02/85	GELINGDE GELAM	BUMAYONG HIGH SCHOOL	1972	16/04/85



Microbeen
BISCUITS

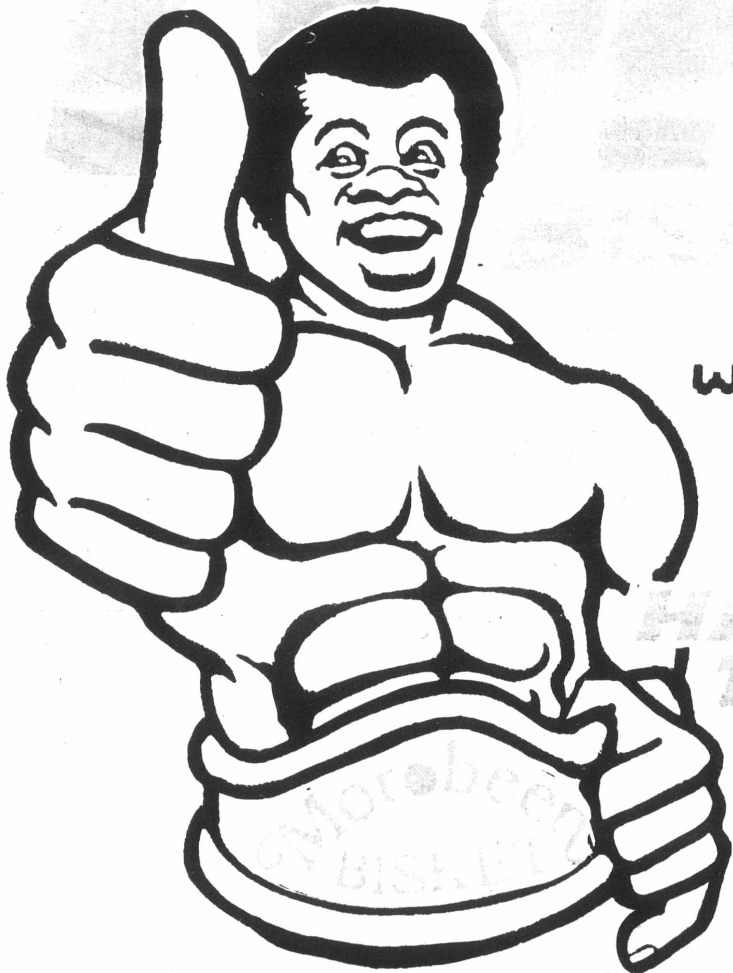
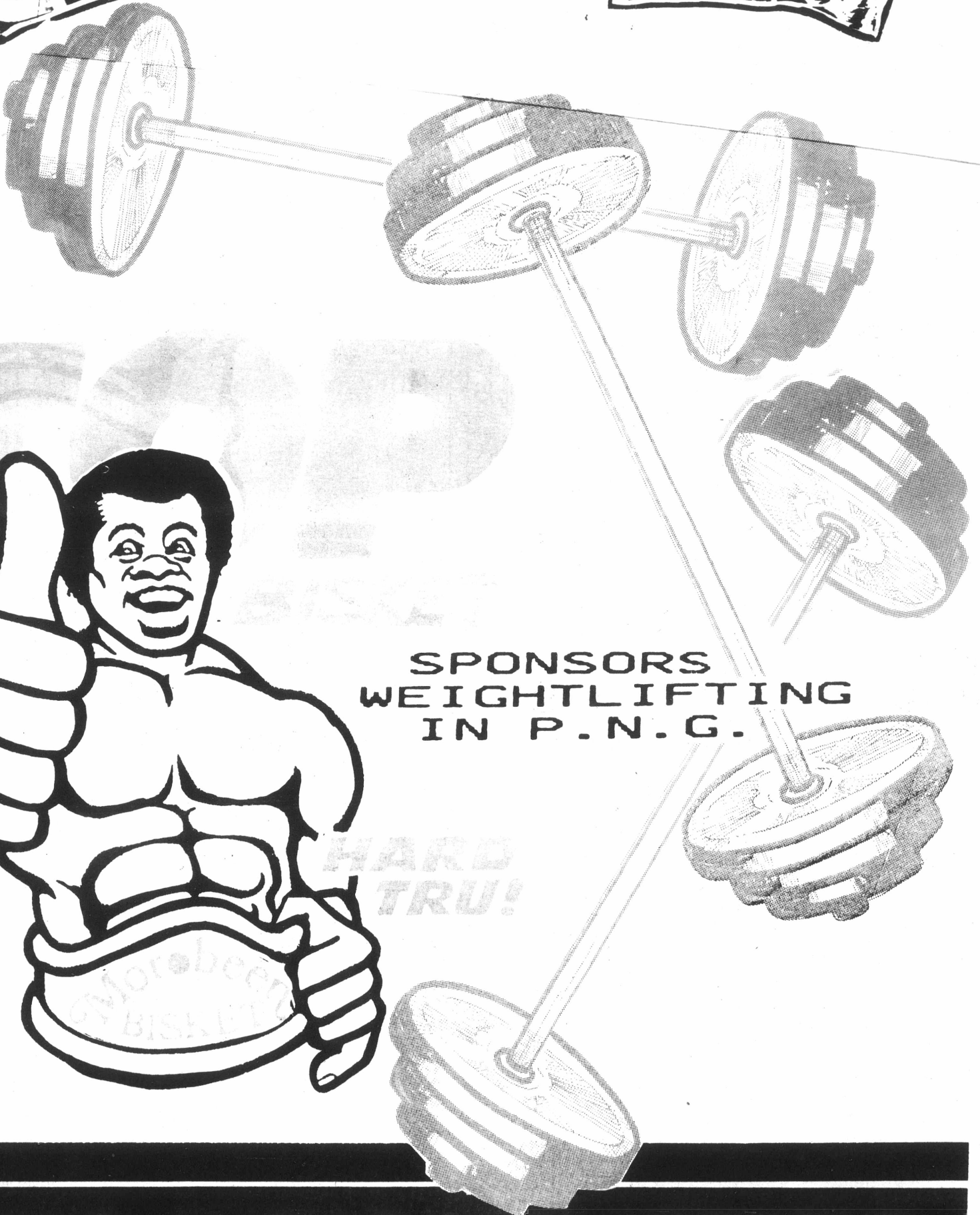

SPONSORS
WEIGHTLIFTING
IN P.N.G.

HARD
TRU!

PNG WEIGHTLIFTING SPECIAL!

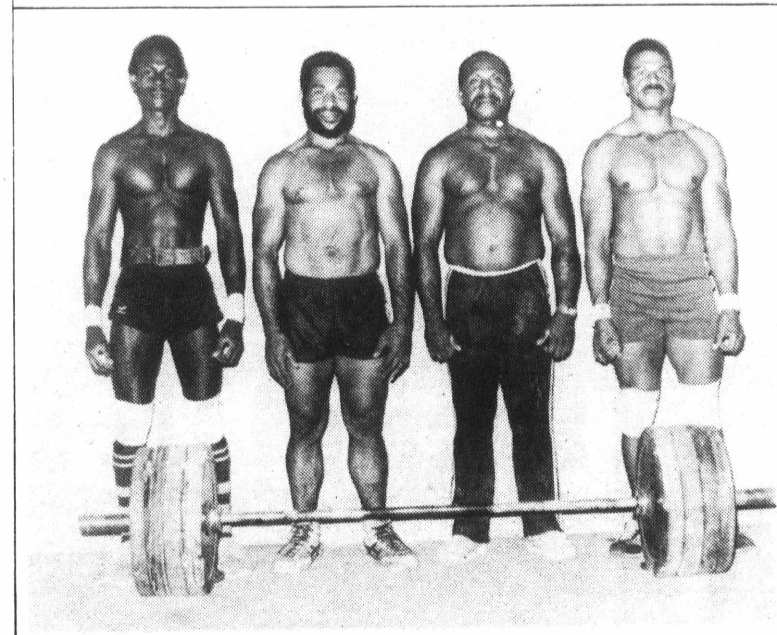

Papua New Guinea first competed overseas in Weightlifting at the South Pacific Games in Suva 1969. Although unsuccessful, experience was gained and paid dividends at the South Pacific Games in Guam 1972 and Tahiti 1975 where small team own 4 gold medals, one silver and one bronze. Geoff Hui, Sibona Oka, Michael Mexico, Kaik Yakopa and the two Seeto Brothers were the Victors. In Fiji Games in 1979 one gold medal and one silver was won and 1983 Samoa Games with one gold medal and one silver was won. The Commonwealth Games held in New Zealand had one Competitor and he won a silver medal.

A team of eleven departs on the 4th August to compete in the Australian Titles to be held in Brisbane, prospects are high as three of the Competitors are lifting more weight than the existing record.

Plans are under way for the two major events in 1986, the Oceania Titles and the Commonwealth Games to be held in Scotland.

Weightlifting is becoming more and more popular as the sport is economical to join, the required bell plus membership fee is all that is required. Gymsnasiums are in Port Moresby, Lae,

Goroka, Mt Hagen and R... estimated 100 people train... football teams have realised to have a session weekly.

The Papua New Guinea W... Association is run by elec... bearers from each province... most interested to promote...

Rigley Tokana Preside... Papimahi Vice President... Secretary and Iwila Jacob... They are confident of more... the country at the next Comr... Games as they have such o... members and record holder... Teiko, Mathew Buka in the... division, Roger Kenatsi ar... Robi middleweight, Eli To... Kamba Kandoa lightweigh... Matsi and Wilson Tokana... weight, and Willy Tokan... weight.

The Papua New Guinea We... Championships would be h... over the Independence w... promises to be a most exciting... over 40 trophies as prizes.

The Associated sport of body... now commencing and it is... commence a MR P.A.P.U.A N.E.V... competition.

Rugby League News

Season '85 — Issue Number 27 — 14 September

asics.TIGER.

Tiger Power!!

Tiger leather boots only K16.50 and K21.50 screw-in studs

HAUS BiLAS SPORTS

PORT MORESBY, LAE, RABAU, ARAWA, GOROKA, TABUBIL, KIMBE, KIETA

Kumuls in for a hard run

By Jack Metta

A fitting end to the national zone championships this weeked is the non-official international match between the PNG President's XIII and

the Australian President's XIII.

The Australian side boasts several Test players in their line-up, mostly dominated by Queenslanders in skipper John Ribot, Wally Fullerton Smith, Mark Murray, Brian

Niebling and Gregory Cornescu. The latter named Queenslanders are not new faces to PNG; they were members of the Queensland Maroons which whitewashed PNG 106-6 in 1983. Perhaps this is PNG's

chance to erase the memories of the humiliating defeat, not so much in the bid to whitewash the side, but to show that we have learnt from the experience and are raring to give them a run for their money.

spectators can expect some brilliant displays from them.

Big John Ribot, tackling machine, Wally Fullerton-Smith and Cronulla-Sutherland centre Dean Carney will be the major personalities on this occasion. The trio's presence will be awesome for the PNG defences.

tireless workers in their own right. Nothing much can be said of the PNG President's XIII as the team was yet to be announced before we went to the press.

Obviously, selectors will look to experienced players for the match. It is envisaged that several rookies may make their international debut to prime them for the hectic international matches ahead.

match will be a valuable exercise to gain experience.

The Australian President's XIII are: — Jonathan Docking, Dale Shearer, Dean Carney, Andrew Ettinghausen, John Ribot (capt.), Grant Rix, Mark Murray, David Hatch, Wally Fullerton-Smith, Bryan Niebling, Paul Dunn, Gregory Cornescu and Less Davidson. Reserves are Chris O'Sullivan and Mario Fenech.

Nevertheless, we must not forget that our southerly neighbours are here on good will mission, to celebrate our tenth independence anniversary in the only manner we know best — rugby league.

PNG, as a developing nation in the world of rugby league need international experience.

The Australian Rugby League's contribution by sending a side to PNG on this occasion is worthy of praise. When one thinks back over the years, it is almost impossible to remember when the Aussies sent a poor side to do battle with old foes. Their record of successes speak for itself as does their always high standard of play.

The squad that meets our boys on Tuesday are fast, strong and very experienced so

The team is plucked from the ranks of Sydney and Brisbane clubs out of the semi-finals contention. Carney will be partnered in the centres by club mate, Andrew Ettinghausen. Jonathan Docking is the fullback and hard working Cronulla captain David Hatch at lock.

Four of Ribot's teammates at Redcliffe in Brisbane — second-rowers, Niebling and Fullerton Smith, hooker Greg Cornescu and halfback Murray will be out to repeat their performance of 1983.

Other players to watch will be Brisbane Valley's five-eighth, Grant Rix and Sydney based Maroon winger, Dale Shearer (Manly-Warringah), who are



WOPA BISKET

Bun, tru!

WOPA TIGERS

ANOTHER CHOICE FOR RUGBY LEAGUE UNIFORMS

We still have the famous Westmont brand from Australia and all NSW club colours

17 jerseys including numbers & PNGRFL logo
17 shorts, 17 pairs of socks

K789

Plain colour jerseys ideal for village teams
A set of 15 with numbers

STRIPS COST EXTRA

AUSSIE RULES
Made in Victoria in all VFL club colours
22 jerseys, 22 shorts,
22 pairs of socks

K195

K715

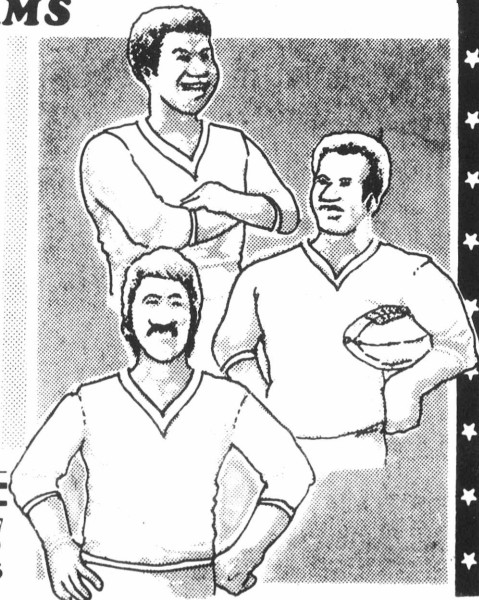

WOO TEXTILE CORPORATION PTY LTD P O BOX 5448, BOROKO PHONE: 25 5097
25 8219
Official Supplier of Rugby League and Aussie Rules uniforms



Papua New Guinea Rugby Football League

Rugby League News Girl of the Week

Draws for zone trials Lloyd Robson Oval — Port Moresby

The following referees have been appointed to the National Zone Championships and Cambridge Cup Fixtures by the P.N.G.R.F.L. Referees' Appointments Panel.

Time	Team	Reperi
Wednesday, 11 September 1985		
5.00	Schoolboys fixture	W Ainui
6.00	Highlands vs Islands	G Ainui
7.30	Northern vs Southern	J Paak
Friday 13, September 1985		
1.00	POM Junior Vs Probs	D Talar
2.00	Islands vs Northern	T Pelis
3.45	Highlands vs Southern	G Ainui
Sunday, 15 September 1985		
1.00	Junior NCRFL vs Pom	D Talar
2.00	Position 3 vs Position 4	
3.45	Position 1 vs Position 2	
Tuesday 17th Sept 1985		

Port Moresby Junior Grandfinals
U 17's
U 19's
School boys U 60's
Australian President 13 vs PNG 13



Thank you Moresby sponsors and fans

Dear Sir,

On Behalf of the President, Mr Brian Rosanowski, and the Executive of the Port Moresby Rugby League, I would appreciate the opportunity to publicly thank the people of Port Moresby for their magnificent support on grand final day, and throughout the 1985 season.

Despite pouring rain, the grand final drew a record crowd. There was not one incident reported to police during the day, and we thank our spectators for their excellent behaviour, and patience, in the wet conditions

which prevailed. Thank you, spectators, one and all.

Our congratulations go to the new Premiers, Hobar Wests, and the runners-up, Air Niugini, on providing a grand final worthy of the premier league. Full credit is due to Hobar Wests for such a successful season, and to their coach Bill Fleming and captain, Henry Miro, in particular.

Sponsors

The League thanks its official Sponsor, S.P. Brewery, for its continued support, Boroko Motors for donating the Player

of the Year Award, and other valued sponsors and the sponsors of all 11 clubs.

We thank the President of the New South Wales rugby League, Mr Tom Bellew, for travelling from Sydney to be our official guest and the Prime Minister and Mrs. Somare for honouring us with their presence.

The League also thanks all clubs, officials and all players for helping to make the grand final, and the whole season, the most successful ever.

Finally, we thank the media for its outstanding coverage of the "Greatest Game Of All" in Port Moresby!

Yours in rugby league,

(Jeffrey Wall),
SECRETARY —
PORT MORESBY
RUGBY LEAGUE.

Part time supporter

SANDRA IROGI, comes from Rabaraba in the Milne Bay province. She is 18 years old, and attends the Community Typing School at Boroko. She likes watching soccer, reading comics and magazines.

Sandra was a parttime supporter for HOBAR West during the Grand Finals, but she is really a KOOL Magani fan. She says that it will be Kool Magani for 1986. DON'T lose hope.

CONGRATULATIONS Pukpuks!!

The Flavours that ROAR

ALL ROUND SCOREBOARD

PORT MORESBY

Hobar West 14 d Air Niugini 0

Zone championships: Port Moresby

Islands 26 d Southern 6

Highlands 28 d Northern 4



HOBAR West took out their third premiership flag after dumping Air Niugini 14-nil to top a great season of rugby league in Port Moresby last Sunday.

By Alfred Kaniniba

"It's just fantastic" said a beaming West coach Bill Fleming after the game.

"We used the strength in our forwards and all the players did what they were told to do," Fleming said.

The game which was played before a crowd of more than 17,000 people and in muddy and slippery conditions.

The game opened up at a fast pace but saw both sides put up a strong defence.

West centre Peter Evera however threw the West supporters into an uproar chanting, West! West! which people heard five to six

West — Moresby Premiers

kilometres away when he opened the scoring with a converted penalty kick to lead 2-nil after 25 minutes of play.

Air Niugini

West led 2-nil at the interval.

The crowd were thrown into suspense as they tried to guess the outcome of the second

However in the opening minutes of the second half, Hobar West Big Henry Miro put the games first try after being set up by young five eight Isa Mai.

The Hobar West supporters were again thrown into ecstasy as they chanted West which echoed across the field.

The try was con-

verted by Peter Evera to lead 8-0

West again took advantage of a dropball of Air Niugini fullback Patrick Ima which saw a backing up Tati Ivra kick right into the try zone. Vavalu Ilagi who was also backing up strongly saw his only chance and dived onto the ball for West's second try.

Peter Evera converted his second goal kick out of three and West surged ahead to a 14-nil lead.

Girty

Simon Girty who was sent on for a replacement for Air Niugini

for breathing space for the players and the supporters but unfortunately his kicks did not have much of an effect as they were artfully caught by young fullback Joe Mirisa.

It just was not Air Niugini's day dropball and unco-ordinated play just threw the Airliners into further confusion.

The Premiership win won them K3000, the 10th anniversary while the veteran of the West players Pex Pekaea took out the K200 man of the match award.

The President of the NSW Football League, Mr Tom Belle who

witnessed the grandfinal was very impressed.

"There has been a marked improvement in the code since I was here 10 years ago."

Mr Belle said he was very impressed with the whole game and especially with the scrummaging.

"The ball was rolled in the way it should be done in the scrum."

He said if Papua New Guinea was able to have a following of at least 10 percent of the population, Papua New Guinea would be a force to be reckoned with in the years ahead.

Akas' saves Tigers

A late try by MBE Tigers' nippy centre Akas Mark saved MBE Tigers from a sure draw and extended the time in Alotau A grade rugby league at the weekend.

Receiving a pass from a scrum near the premiers, Allan Hivoilele's tryline, he dashed over at the 77th minute mark to give the cats a much needed try.

For a total of 39 minutes, the two sides were levelled 6-all after both sides had exchanged leads.

The Tigers hit the front 19 minutes into the game when centre Willie Kalit outpaced the Hivoilele defence to break the drought. Ome To'oro failed to convert and the cats led for the next nine minutes.

At the 28th minute, Hivoilele second row, Jimmy Irona crushed over near the uprights with several Tigers defenders clinging to him Manoa Panta made no mistake with the conversion and the 1984 premiers led 6-4 until the 37th minute when they were penalised in front of their own goal posts.

To'oro made no mistake with the penalty goal and the scores were tied 6-all at the break.

The second half was a tight tussle between the two sides as they probed for openings.

Neither side scored for 36 minutes of the half until Akas Mark scored the winning try which To'oro converted to give the Tigers a 12-6 win.

Scrummages went to Hivoilele 22-12 and penalties favoured Tigers 9-3.

In the B grade, MBE Tigers and Kula Sharks drew 8-all despite two five-minute extensions.

The grand final is scheduled to take place on independence day with minor premiers, Cheong's United clashing with MBE Tigers in the A grade and the winner of Kula Sharks/Tigers match meet Cheong United in the B Grade.

Panthers down top Tigers in Tari

LAST weekend's grandfinals in Tari League between Tigers and JD Panthers saw Panthers defeat Tigers 10-8 in muddy conditions before a crowd of 600 people. Both teams played hard and tough football. However the wet conditions saw a lot of dropped balls.

Referee Lukas Kalava however controlled the

game well and was able to see the finals through.

Tigers had been leading from the start in the competition but fell prey to the Panthers on the big day. Panthers will now be attending the cup in Mount Hagen.

In the reserve grade between Brothers and Royal Hawks we saw Hawks edge out Brothers 4-3 in a tough encounter.



First Premiership for Bomana in N.C.R.F.L.

BOMANA took sweet revenge for their major semi-final loss when they disposed of Sagaga 22-4 to bag their first ever premiership in the NCRFL at the Sir Hubert Murray Stadium before a crowd of more than 800 people.

By Joseph Kau

For Bomana it was quite an achievement as this was only its first year in the NCRFL after a four year lay off from the then Suburban League.

Bomana's three teams won their respective grandfinals.

Credit must be given to the players as they played a hard tough and disciplined game through out.

Saraga on the other hand have themselves to blame for their second consecutive

grandfinal loss as they wasted valuable time on softening up tactics in the first half in which Bomana capitalised scoring most of their points.

The first points of the game came only four minutes into the game when burly Bomana second rower, D.Homoa barged his way through a horde of Saraga players to score beside the up rights which Alfred Kumasi converted.

Later Simon Kerekere followed through later in a classical display of backline movement to send Kumasi in for a converted try to put Bomana ahead 12-nil.

Saraga at this stage just did not seem to have any answer to the Bomana onslaught, which was effectively led by Bomana's front trio of Wate, Sharp and

Tobing who were capably assisted by K. Kangal, A' Kumasi and J. Malana.

Softening up tactics employed by Saraga were given back in the same way by Bomana.

Kumasi however was penalised for late tackling of a Saraga player which saw R. Mareva convert to trail 2 points to 12.

This seemed to herald better things to come for Saraga but this did not turnout so ... Kumasi lived up to his expectations when he dived over beside the uprights to score and convert his own try.

Saraga came on more determined in the second half and limited Bomana's attack to a try by K. Sharp, but could not find the push for them to score and eventually ended up going down to Bomana.

JOIN THE COMPETITION!

WIN WIN K500

Cash Weekly

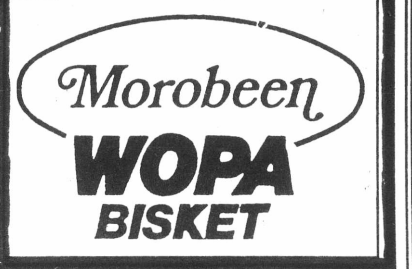

CO-SPONSORING

"Spot The Ball"

EVERY WEEK STARTS AUG, 7TH

... and it's ONLY in....

Wantok

Every Thursday

25t

DON'T MISS OUT!

MORESBY

**PREMIERS
"A" GRADE
HOBAR WESTS
"B" GRADE
RLC PAGA
"C" GRADE
HI - LIFT HAWKS**

SIMBU

**1985 PREMIER
BROTHERS**

HAGEN

**"A" GRADE
GRANDFINAL
CALLED OFF:
BROTHERS vs WALLY ROYALS
(2) - (2)**

ALOTAU

**"A" GRADE
16TH SEPTEMBER
GRAND FINAL
CHEONG UTD
vs
MB TIGERS UNITED**

KOOL

**SPONSOR
WD&H
(P.N.)**

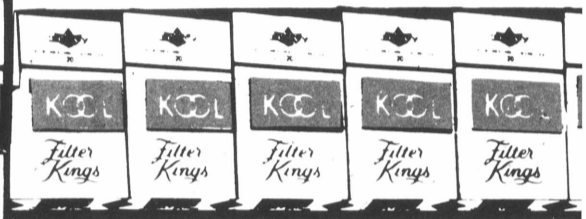

No.1 MENTHOL

10TH ANNIVERSARY SPECIAL

DEDICATION and commitment to rugby league by all concerned has always been cited by league authorities as the basis on which progress can be made by reaping benefits of success.

"There is tremendous talent among the players. You will become a force but that depends on the players. You have to dedicate yourself and show commitment to the sport. Don't underestimate your own ability."

These words from the National Coaching Director, Keith Collins two years ago reflect the potential of Papua New Guinea as a rugby league force.

However, one wonders whether such advice has actually been implemented over the years.

This week, Papua New Guinea celebrates ten years of independence. There is much for Papua New Guinea to be proud of. Its achievements over the years despite periods of uncertainty has received widespread praise from its contemporaries. Indeed we have coped within the scope of our resources.

The same can be said of rugby league in Papua New Guinea. But the question that persists in the minds of many is: Has the standard of rugby league in this country improved since independence?

Critics in the past have shown a negative

view, their attitude being enforced by the occasional thrashing PNG receives at the hands of more powerful league nations.

The results of these unfortunate outcomes overrules the glories of successes that PNG has achieved over the years.

The progress and development even in rugby league are a never ending process.

We have trod on at our own pace, learning and experiencing as we go, and then putting what we have learnt and gained back into the sport. Thus the trend continues.

Much has happened for rugby league in this country since independence. Perhaps the most prominent of these changes has been the establishment of a national body to look after the overall interest of rugby league in this country.

Not far behind in prominence is Papua New Guinea's inclusion on the International Board as a full member, bringing to five, the total number of rugby league playing countries on the board.

This is an important achievement because Papua New Guinea has a say in the development and fostering of rugby league throughout the world.

It indeed reflects an air of independence for Papua New Guinea Rugby League simply because the sport in this country cannot be

dominated by the decisions of those who are not familiar with our situation.

Achievements

Other achievements during the years of independence, include the successful launching of the four zone system and the annual championships which has lasted until this day.

If you remember, the zone system replaced the often tension packed traditional rivalry between Papua New Guinea and which was eventually phased out in 1974 following the riot of 1973.

The years of independence also saw Papua New Guinea set the pace for participation in the international arena.

The national side for the year which included names (which were to prove household words in later years) such as John Wagambie and Tara Gau, played an unofficial Test against England in Port Moresby.

England won the match by a small margin but Papua New Guinea had learnt from the experience of playing hosts and successfully staged the Pacific Cup tournament in the same year in Port Moresby involving Australian State teams and the New Zealand Maoris.

The Maoris won the cup but PNG and its Australian counter-

by Jack Metta

parts crossed the Tasman Sea in 1977 seeking to wrestle the cup from them but the Maoris were reluctant to let go.

In retrospect, Papua New Guinea's achievements in rugby league during the years of independence certainly laid the groundwork for major upheavals in rugby league.

Since that year, a number of overseas teams have visited Papua New Guinea playing matches at national, regional and club level and provided much entertainment for rugby league fans at various centres for the country who otherwise would not have been able to see overseas teams in action.

In turn, Papua New Guinea has gone overseas to play matches on a number of occasions and have proved themselves both on the field and off as sportsmen and ambassadors of the country.

Participation

It needs to be stressed that international participation by Papua New Guinea was not only confined to senior players.

Papua New Guinea junior footballers have been able to make overseas trips and in turn were enthusiastic about accommodating their junior counter-

parts from overseas in domestic matches.

Our under 60 kilogramme schoolboys teams in past years have been able to promote a good image of Papua New Guinea in Australia for example and won the hearts of the Australians with their gutsy performances.

One cannot honestly pinpoint Papua New Guinea's status on the world scene but true to say, we have tangled with the best of them.

At times, we have revelled in the glory of accomplishing the impossible and at other times, we have hung our head low in humiliation and defeat.

But for us, it has always been losing with humility and winning with dignity and pride.

We've had no less than three tours since independence — to New Zealand for the Pacific Cup in 1977, France and England in 1979 and again to New Zealand in 1983.

In turn we have accommodated New Zealanders, Australians, Britons and Frenchmen on separate occasions throughout the decade.

Unlike many critics who would base their judgements on PNG's performance to assess PNG's standing on the world scene, I share the sentiments of many of our leaders who say that "Rugby League is always the winner at the end."

The development areas of the world need international competition. As Harry Edgar of OPEN RUGBY LEAGUE wrote on PNG's first

win against the British Amateur Rugby League Association in 1982: "Papua New Guinea finished 18-16 winners, after an amazing second half comeback. But it was a result — PNG's first win in three encounters against BARLA — that will do the Kumuls far more good than Britain harm."

Commercial

The commercial value of rugby league to the private sector has blossomed over the years. Thousands of kina are being poured into the game in what the president of the Papua New Guinea Rugby League, Ben Sabumeri sees as "the confidence, the private sector sees in the future of Rugby League in this country."

Sponsorship kina has been put into prizes, clubs, major tournaments, referees and coaching courses and the establishment of institutions such as the national coaching scheme.

Perhaps the Prime Minister, Michael Somare's words can sum up the situation: "Government alone cannot be expected to improve the 'quality of life' for the people and provide sporting facilities... We need and we seek the support of the private sector and developers to provide this kind of facilities."

Administration

One area which really needs picking up is the administration side of rugby league. As rugby league grows so does the need for good effective management of club and league affairs.

Over the years, bad

management has resulted in financial and administrative problems for a number of clubs and leagues throughout the country.

Of late, ineffective administration has deprived potential national representatives from three main centres, Daru, Wewak and Madang from participation this week. The onus falls on the administrators because if they do their job well, it will mean that Papua New Guinea can produce the best their is.

Hectic

On the future calendar, PNG has a hectic game schedule ahead for both domestic and international involvement over the next ten years.

The highlight of course is the culmination of the international matches into the world club contest later in the decade.

The road ahead is a testing one for PNG because it will reflect the question of whether we have learnt from our experiences.

There is no doubt that rugby league can lay claim as the national sport in PNG. As Martin Adamson, former PNGRFL official once wrote: "natural talent bounds and need only be harnessed and guided to make PNG a force in the international arena. PNG may never dominate world rugby league, but it will enrich it with enthusiasm."

I have come from 50,000 years ago so they think, others say I was born on 16th September 1975, let my arrows fly another 50,000 years. — Kumalau Tawali.

Kiunga a wealth of rugby league

ALTHOUGH there is a gold and copper mine in the Western Province at Mt. Fubilan near Tabubil, the province's goldmine of Rugby League talent is at Kiunga.

Rugby League football has naturally developed in Kiunga over the last 3 years as Kiunga being a major government, business, mission and communications centre has provided the combination for the code to grow.

As in Rugby League anywhere, the most important factor is the players. Players from different provinces in Papua New Guinea have all contributed something to the standard of the game in Kiunga.

With the mixture of the speed of the local Western Province players, the strength of the Highlanders and the Savvy of players from major league centres like Port Moresby, Lae, Rabaul there is emerging a Kiunga

style of playing Rugby League football.

The style consists of hard and fast running with decisive defence, backed up with skill.

In 1985, players have shown greater dedication to training than in previous years, with clubs training up to 4 times a week during the competition and 5-6 times a week during the finals.

The extra dedication and discipline has resulted in a higher standard of game.

One attitude that players need to develop, is that they are the backbone of their respective clubs and the league as a whole. Players in Kiunga must assist both club and league officials with both in moral and financial support so that the code can develop to a higher level.

If players are the basis of clubs, then the club is the basis of the league.

In 1985 the clubs

have co-operated better in organising the league.

In developing the code in future years, the club officials should contribute more effort to the league and leave inter club rivalries on the rugby field.

Organising

1985 has been the best year so far in organisational matters, but the club officials should realise that criticisms of the league are actually reflections of their shortcomings of not giving enough support and assistance to the league.

Overall, the Kiunga Rugby League is poised for better things, but the co-operation and assistance of all players, club officials and supporters must be mutually maintained so that progress in the future can be made.

This year, Kiunga Rugby League has only been an associated league, as the league has been

laying the organisational ground work.

One criteria that has prevented the league to be fully affiliated with the PNGRFL is the lack of suitable fenced oval.

This facility is now under development and should be ready for the 1986 season.

The Kiunga Rugby League will be a fully affiliated member of the Papua New Guinea Rugby League in 1986.

Kiunga promises to be a major centre in the Southern Zone and certainly will give the other centres a good shake in the Southern Zone trials.

The future of the code is ensured with the operation of the Kiunga High School Rugby Football League, which is in its second year of competition.

Overall, the code of Rugby League has a great future in Kiunga, with the players officials and supporters aiming for higher and better goals in 1986.

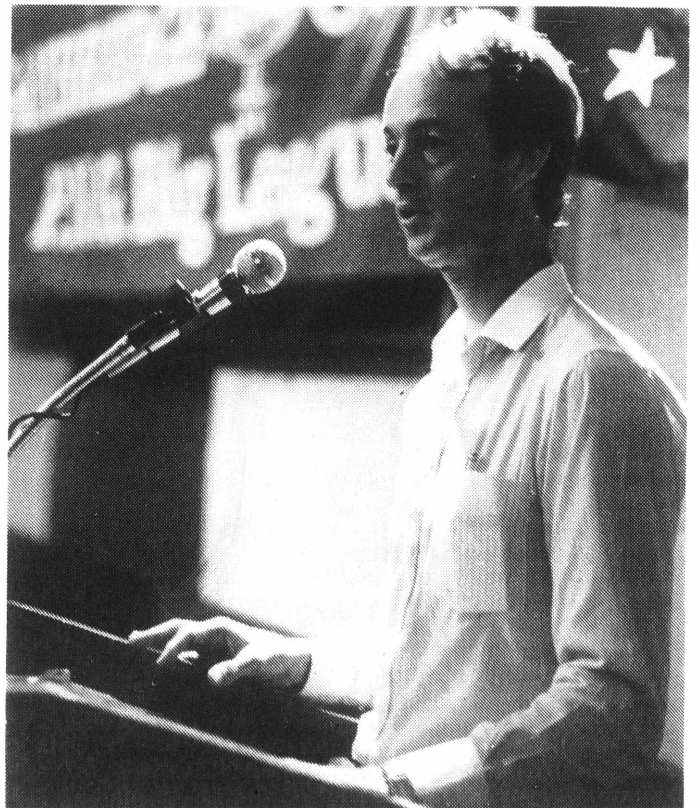

The Cambridge Cup — a boost in PNG league

The Managing Director of Rothmans of Pall Mall in Papua New Guinea who recently announced the new Cambridge cup competition which will begin on the 22nd of September. Rothmans has injected K100,000 over the next three years for the development of rugby league in Papua New Guinea.



● This player is about to do a classical copybook pass.



● The Highlands Zone celebrate their victory when they defeated Southern in Port Moresby in 1983.



● Aia Ma Naio... Aia Ma Naio... Aia ma naio naki endi Pereno... Hey boys if you keep on singing I'll take you in for Monday's Chin H Meen Super Sound.



● Hey Pereno! who's coming

WD & HO WILLS (PNG) LTD

MANUFACTURERS OF

BLUES

KING SIZE FILTER CIGARETTES

SUPPORTS

HIGHLANDS RUGBY LEAGUE THROUGH SPONSORSHIP OF THE BLUES BROTHERS

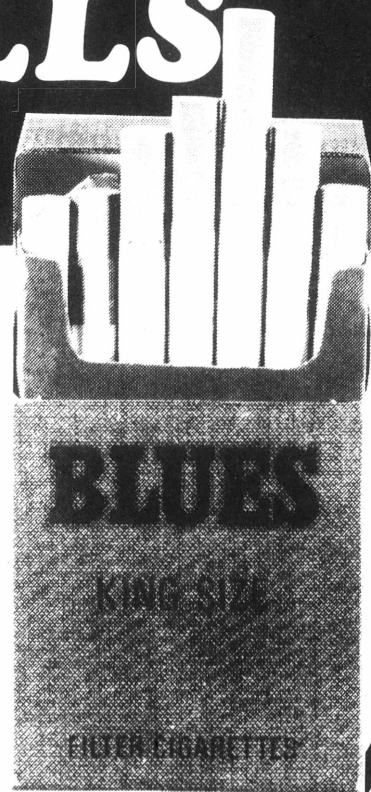



**PAPUA NEW GUINEA
NATIONAL RUGBY FOOTBALL LEAGUE
CHAMPIONSHIPS — 1985**



Kungas KUVEU



Phillip RALDA

TIMETABLE

WEDNESDAY, SEPT 11TH

- 5.00 PM SCHOOLBOYS — GEREHU vs KILAKILA
- 6.00 PM HIGHLANDS ZONE vs ISLANDS ZONE
- 7.30 PM NORTHERN ZONE vs SOUTHERN ZONE

FRIDAY, SEPT 13TH

- PORT MORESBY
- 1.00 PM JUNIORS — POSSIBLES vs PROBABLES

SUNDAY, SEPT 15TH

- 2.00 PM ISLANDS ZONE vs NORTHERN ZONE
- 3.45 PM HIGHLANDS ZONE vs SOUTHERN ZONE
- 1.00 PM JUNIORS — NATIONAL CAPITAL vs PORT MORESBY
- 2.00 PM POSITION 3 vs POSITION 4
- 3.45 PM POSITION 1 vs POSITION 2

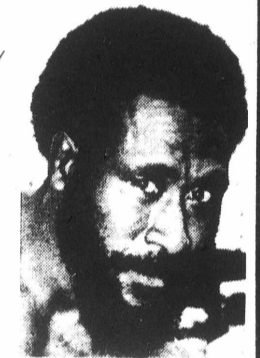

Henry MIRO

BRIAN A TAYLOR
SECRETARY



**10TH ANNIVERSARY OF INDEPENDENCE
RUGBY LEAGUE INVITATION MATCH**

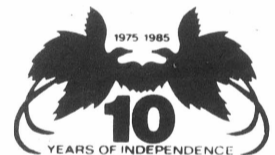

AUSTRALIAN PRESIDENT'S XIII

VS

**PAPUA NEW GUINEA
PRESIDENT'S XIII**

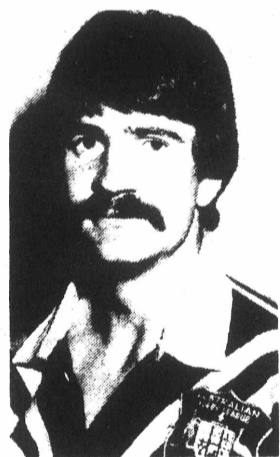

John Ribot
Australian
Captain



Benias SABUMEI
Papua New Guinea
President

TUESDAY, SEPTEMBER 17TH — 3.00 PM

ADMISSION — K2 ADULTS 50¢ CHILDREN

CURTAIN RAISERS

- SCHOOLBOYS — UNDER 55 KGS NATIONAL CAPITAL vs CENTRAL PROVINCE
- GRAND FINAL — PORT MORESBY JUNIORS — UNDER 19's
- GRAND FINAL — PORT MORESBY JUNIORS — UNDER 17's

- 2.00 PM
- 1.00 PM
- 12 NOON

GATES OPEN — 10.00 AM

BRIAN A TAYLOR
SECRETARY

Goodbye town competition; welcome village freestyle

IN Goroka, village competitions will begin straight after the independence celebrations.

These competitions could be more of a crowd thriller than normal town competitions which have just been paced out with the final countdown which went to Air Niugini.

Air Niugini defeated its next rival, Collins and Leahy United last weekend without the help of stocky five-eighth, Ifsoe Segeyaro who was banned from playing the three last matches because of some ill-play in which he was victimised.

Tigers, who at one stage, were at second play on the points tally table were discarded by other teams in the fight for premiership. And if Tigers had

been able to keep up their pace in the final matches, their victory chart would read as winners of Goroka rugby league in five successive years.

Coach Stainer Sapu is one very disappointed member of the Tigers club. He blamed the criteria used by the league to have his team at second place to defend their strength against third and fourth rated teams.

Tigers played three games on Saturday, Sunday and Wednesday the week prior to the grand final weekend and that was two games too many for his team in a week.

"We were, by my understanding, supposed to meet the winner of third and fourth play-off. But that was not the case. We had to play

freestyle

by BENNY BOGG

the fourth and third teams on the ladder and that was a new play for the finals for me. I'm very disappointed," Mr Sapu said.

But Tigers are also happy that from their nucleus the Highlands Zone selectors have appointed three players, Dickson Kimi, Sam Karara and Ken Kemutafe for representation at the second highest level of league competition in the country.

Mr Sapu will take on the responsibility of administrator of the club in the coming season and former Kumul repre-

sentative player, Francis Matmilo will be the club's coach.

Competition at village level is rather wilder and thrilling still and the matches will draw close on the winner of various shields being made available by provincial members and businessmen in the province.

Goroka is known as the league state of the Highlands region and the town dwellers will find entertainment in abundance at villages because Goroka rugby league will be kept alive all year round.

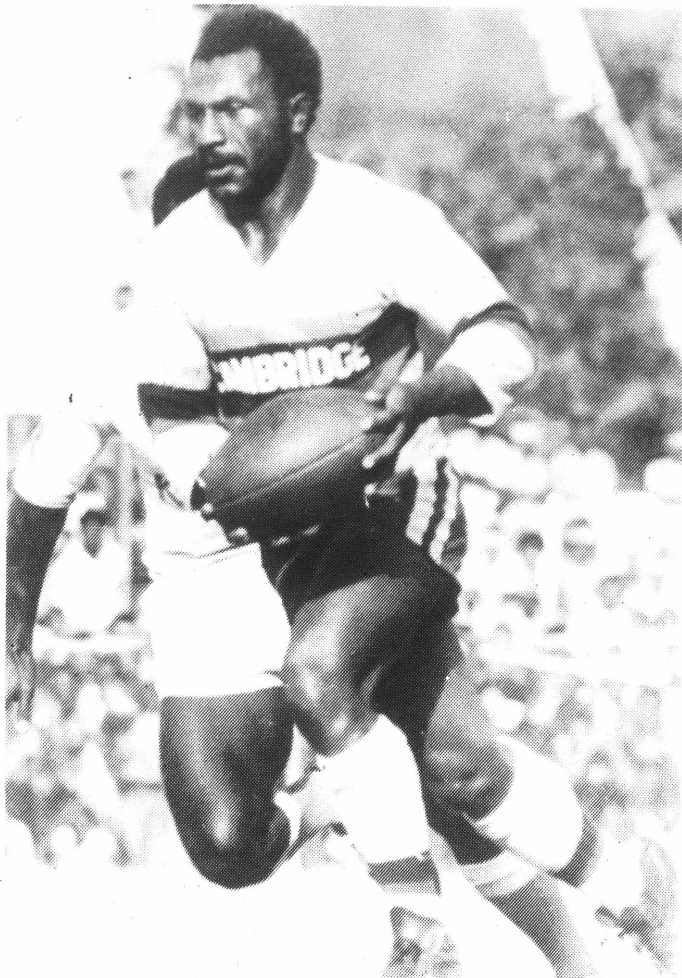

● Dashing young Gorokan Ifsoe Segeyaro who has been

one of the regular players in the Highlands Zone side.

WE

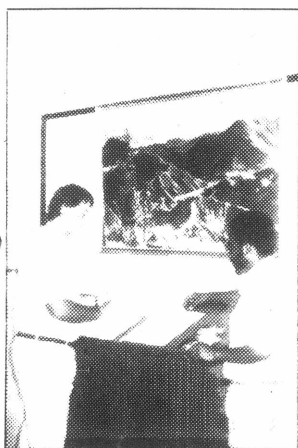

DESIGN



MANUFACTURE

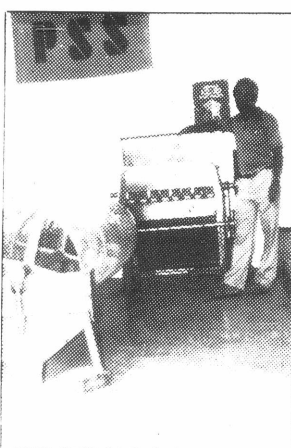

SUPPLY

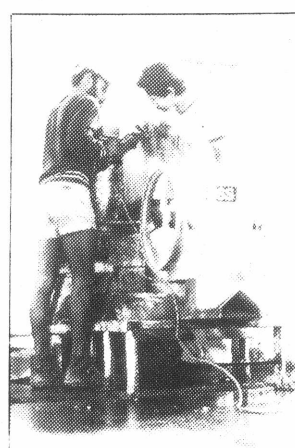

INSTALL

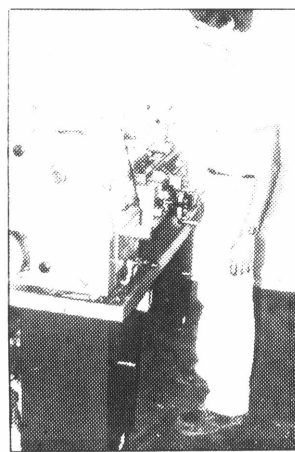
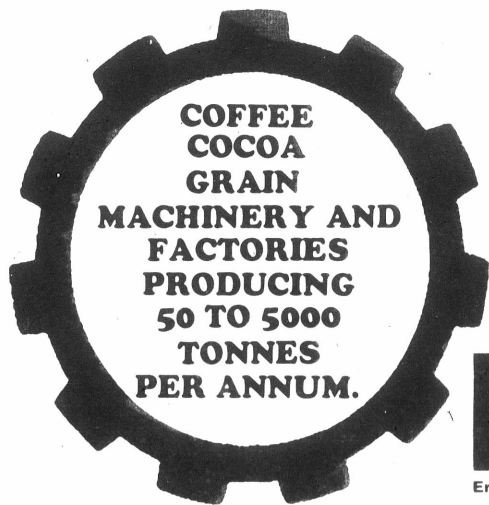

SERVICE

PSS

Engineering - Agrochemicals
Plantation Supply and Services Co Pty Ltd
P.O. Box 92, Goroka
Phone: 72 1069 (6 lines)
Telex: NE 72666



NGPS

Pastoral - Industrial
New Guinea Pastoral Supplies Pty Ltd
P.O. Box 83, LAE
Phone: 42 2635 (5 lines)
Telex: NE 44188

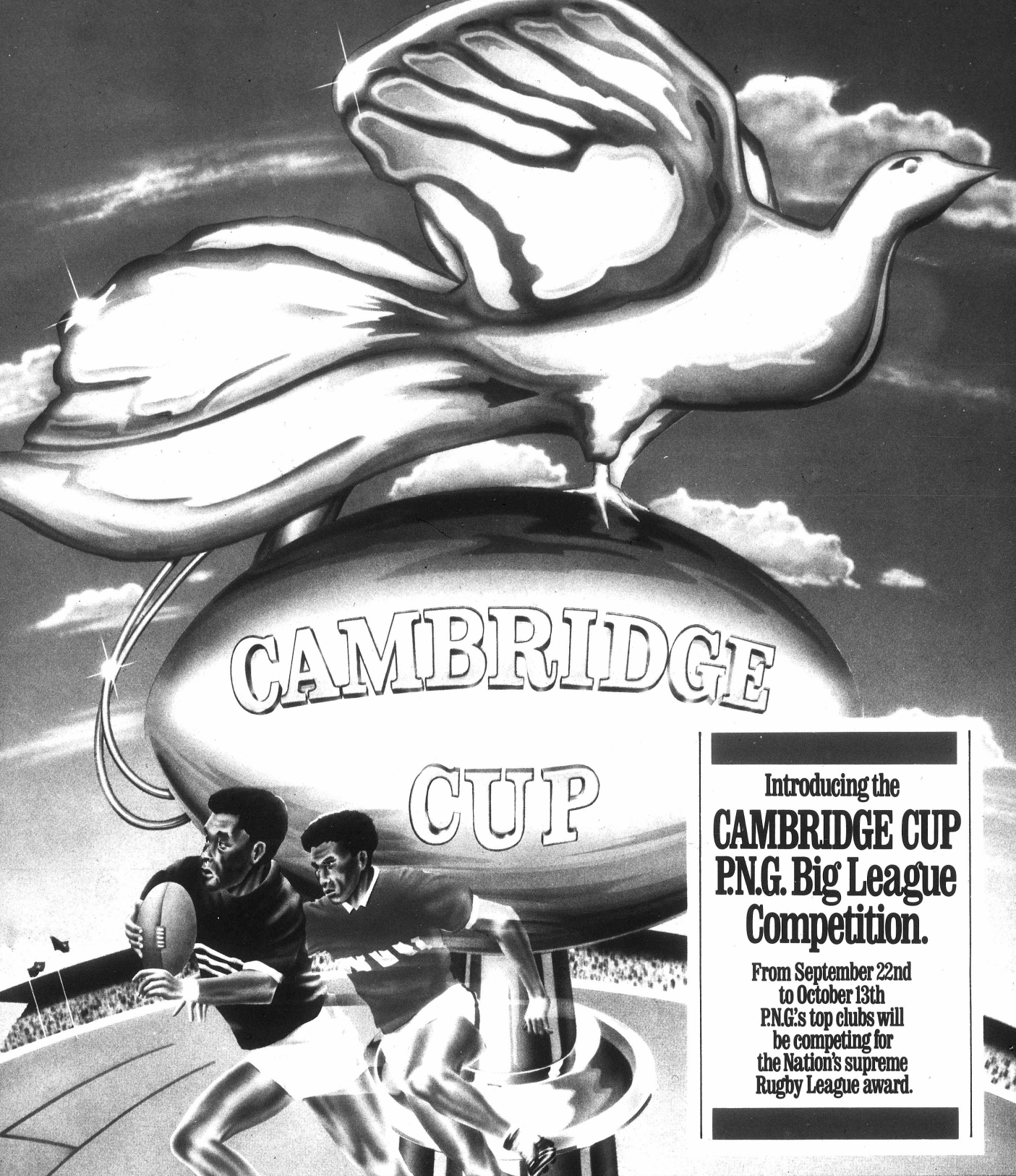

CAMBRIDGE

CUP

Introducing the
CAMBRIDGE CUP
P.N.G. Big League
Competition.

From September 22nd
to October 13th
P.N.G.'s top clubs will
be competing for
the Nation's supreme
Rugby League award.

CAMBRIDGE CUP
P.N.G. Big League

Rugby League fostering unity in the Highlands



HIGHLANDS ZONE STAR KURI NIL IN FULL FLIGHT

UNITY through sport and the promotion of brotherhood is the theme of the Highlands Rugby League competition which has been played at the Union oval at the UPNG campus over the past few weeks.

Pioneering founder of the league and president, Werea Mori — a former Port Moresby Brothers league star — contends that the competitions, involving students on campus, strives to foster regional understanding and student solidarity.

"Students are generally seen by the public as intellectuals. We want to set an example by promoting unity among the students through rugby league." Mori made it clear that there are no political motives behind the formation of the league.

"There has been moves in the past to use the league for political interests.

Under my leadership, I want to see students from the five highlands provinces involved in a sport which they are familiar with and which we all can play and enjoy in the true spirit of sportsmanship and unity."

With an able executive under the leadership of Mori, the league is proving to be a popular attraction for students and local residents alike on Sundays. Organisations have been highly commendable ensuring a smooth and entertaining run of football for the league over the past few weeks.

One aspect of the league is that it is not only confined to students from the Highlands, but students from other provinces are allowed to play for one of the five provincial teams. Provision is made under the league constitution to field a limited number of "outsiders" to ensure

that most of the students from the highlands region are given a chance to play.

The league has not only being instrumental in producing players for output into the town competitions, but has also attracted some players who have already made their names elsewhere. Among them, former internationals, Karava Haiveta and Jack Metta.

Haiveta is involve in refereeing on campus and Metta is a player-coach with the Souths club on campus.

The league involves over two hundred students and officials, sub-divided into five teams with an A and A reserve grade sides each.

Mighty Souths represent the Southern Highlands, West Kanges, the Western Highlands, Enga Mioks, Enga, East Nokondis, Eastern Highlands and Simbu Angras the Simbu province.

Enga MP, Paul Torato is the patron for this season. It seems the Engas are heavily involved in the league. Businessman, Daniel Inugu who owns a tuckerbox near the University is the official sponsor of the league this year. He has put up K400 to be paid out as prizes at the end of the season.

The 1985 premiers and runner-up in the A grade will recive K150 and K100 respectively while the reserve grade premiers and runner-up will receive K100 and K50.



PNG COFFEE

PNG COFFEE



**PAPUA NEW GUINEA
COFFEE INDUSTRY BOARD**

**BEFORE OR AFTER
PLAYING — REFEREEING —
SPECTATING — OFFICIATING
TRY A CUP OF
PNG COFFEE**

**YOU WILL BE SURE YOU ENJOYED BOTH
THE TASTE OF OUR COFFEE
AND THE GREATEST GAME OF ALL**

**PNG COFFEE INDUSTRY BOARD
P O BOX 137 GOROKA. EHP**

PNG COFFEE

PNG COFFEE

SIMBU LEAGUE TO INTRODUCE THE CLUB SYSTEM

SIMBU Rugby league will be a force to be reckoned with in the highlands in the years ahead.

President of the Simbu Rugby League Association, Mr Clement Poye who has been president of the association since last year, said the players were getting better which was boosting the standard of the game.

Mr Poye however said that he was trying to implement the club system to make the competition keener.

Port Moresby has a club system and Australia has the club system and that is what makes the league players and the games much more competitive," Poye said.

"I've tried to get this moving since

last year and so far this has clearly shown that seven players would be representing the highlands zone are from the Simbu league."

The Simbu league has eight teams each of which has an A grade a B grade and a C grade a total of 24 teams. The games are played both on Saturday and Sunday.

Sponsorship is also strong in the Simbu league and a number of business houses or private business men have sponsored teams in the competition.

Glen Helton Timbers sponsor Magani and the East club, Collins and Leahy sponsor Brothers, Geru Holdings sponsor Souths and Tigers. Mount Wilhelm Business Group sponsors

Hawks while Chimbu Wholesale sponsor Tarangau.

As the club system is one of the immediate ideas being implemented in the Simbu League, the league could surely be a leader in this type of a system in the highlands.

"It is however up to us to make the club system help in trying to help develop the game," Poye said.

He also said that he was looking to improve the field, as he was hoping that next season Simbu League should be the official host for the Highlands zone trials.

This season however has been 100 per cent better than last year, Mr Poye said.

Victory for a Chimbu coach

CHIMBU'S Brothers' coach Wali Yagiwera notched a double victory this league season in the Highlands region when he took his team to rattle the grand final scoreboard 12-3 against a determined Magani bunch.

Wali Yagiwera's name is inscribed in the imaginary book of great coaches of the region as he won for himself the name of a magnificent coach when he took his players through the finals.

Also from Chimbu and along with his name is that of the coach of Tigers' junior grade. Tigers defeated Magani in the grand final in a match no different to most 'A' grade matches in the Highlands region.

From Chimbu league, the leaders this season were Brothers, Magani and Souths. Souths who won last years premiership could not spark an equal-strength with the two leaders this year and was dropped to being the third best team in the competition.

Brothers' Bal Numapo and Mawe Kaupa who are stars of the Highlands spectators made it possible for coach Wali to score his victory.

The two livewires of the Brothers' lineup at the grand

coach

final have been also further rewarded — they will relive their grand final as they fight a set of highly tough matches in Port Moresby this week — they are in the zone trial list.

Souths in Chimbu will not forget their loss this year. They were hot favourites from the start of the season but their shaky performance at the climax of the season will be a haunting shadow over the coach and a few very good sportsman in the side.

Souths will go through hot water in

their determination to bag next seasons trophy and restore the name that was theirs the season before last.

Chimbu will relax its rugby league crowd during the next few months and prepare for another season of fireworks. Itchy feet and hands will find village competition or touch football the next best sport in the meantime.

Then from the word go in Chimbu, sparks will fly again as uncles clash against each other for the love of the sport, and to build up another period of excitement for another climax

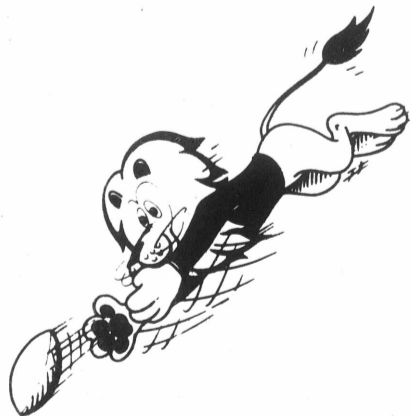

ANGCO

(a 100% nationally owned company) Pty. Ltd.

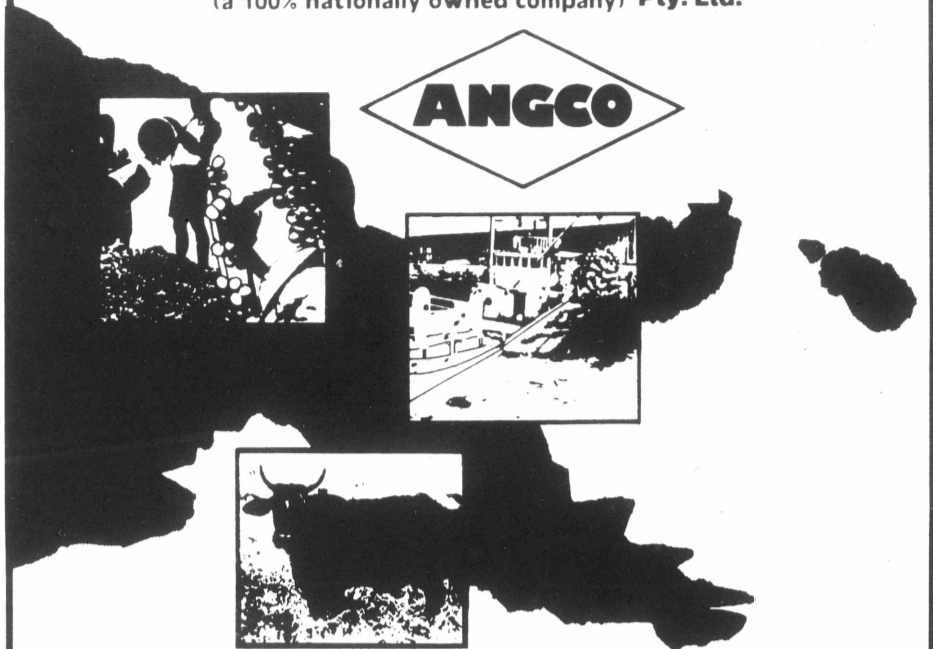

Working Nationwide to make a Better Nation...

ANGCO, as PNG's largest coffee and cocoa exporter, helps the local growers in PNG by purchasing coffee and cocoa at competitive prices. ANGCO is also involved in the production of beef at Kaitaki in the Central Province.

	PHONE	FAX	TLX
GOROKA (Head Office) Airport Rd., P.O. Box 136, Goroka	72 1677	72 2692	72622 ANGCOM
KIETA	95 6065	95 6043	95860 ANGCOM
LAE	42 3163	42 3408	44184 ANGCOM
MT HAGEN	52 1461	52 1436	52082 ANGCOM
RABAUL	92 1233	92 1589	92954 ANGCOM
SYDNEY	(302) 439 3222	(302) 439 7961	AA 22410 ANGCOM
WEWAK	86 2604		

LAMANA W/SALE

FOR ALL YOUR TRADE STORE SUPPLIES

LAMANA TIGERS

FOR 85 PREMIERS



Highlands league stars in action during the Zone trials in Port Moresby last year. The Highlands zone an awesome threat to the league giants in PNG.

Highlands a real force

These highlands Rugby League stars in Action are no doubt house hold names in the Highlands.

And just the sightest word in any town in highlands that one of these stars is in town really gets the fans all excited.

To the boys who follow rugby league in the highlands it is a dream that they all share of one day becoming a star.

But until then the Highlands has really proved to be a real force in the PNG league scene and it is

quite evident that in the next few years the competition will be one of the best in Papua New Guinea.

The Simbu League has already set the example of introduc-

ing the club system and if this can truly take off in a big way. The Highlands Zone team in future years will surely be a strong force in the Rugby League world.

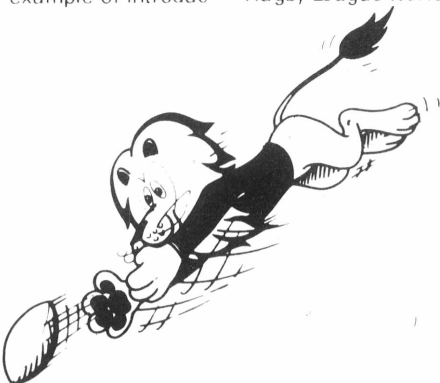



BUSU MOTORS

For all your auto electrical repairs in Goroka

PHONE 722648 P.O. Box 785 GOROKA.

10TH ANNIVERSARY SPECIAL

National Coaching Scheme

By Keith Collins PNGRFL - National Coaching Director

THE Papua New Guinea Rugby League National Coaching Scheme began in June 1983. Because of the interest shown by two great Papua New Guinea Companies, S.P Holdings Pty Ltd and Rothmans of Pall Mall PNG Ltd, these two companies, made sponsorship available for the PNGRFL. To employ a National Coaching Director for a period of three years to try and establish a foundation of knowledge and expertise that would help bring Papua New Guinea to a higher standard of Rugby League.

The idea was to coach coaches in PNG and bring them to a higher standard. Also to allow any interested person the opportunity to complete a Preliminary Coaching Course and learn more about the greatest Game of all. They would then be able to carry on to a Level 1 Coaching certificate Level 2 and Level 3.

All these accreditations go further into Rugby League Coaching involving, Sports Medicine, Physiology and Psychology of Coach-

ing, Biomechanics, Sports Administration and Management.

To establish a base for this progressive Learning Programme, was going to be a big job. The National Coaching Scheme decided, that the highest level of proficiency was necessary and by learning the skills and techniques of Rugby League correctly, players would automatically raise the standard of the game. This is happening. Rugby League has improved in PNG, since June 1983 when Queensland defeated us 106 to 3. Coaches are certainly more aware of the help there is available to them through the National Coaching Scheme.

The competition for Coaching positions is keener than ever before. Clubs are aware that we have level 1 Coaches being Accredited and are seeking them to coach their teams. These coaches will bring into the game that added commitment to training and learning of skill and technique that will put PNG up beside the best Rugby League playing

Countries in the world.

The Papua New Guinea Referee's Association, is working closely with the National Coaching Scheme and they have had 263 people sit for the Referees Exam, 157 people passing, with a knowledge of the Rules of the Game sufficient for them to Referee.

The number of coaches accredited through the National Coaching Scheme is: Preliminary Coaches 475, Level 1, Coaches 152, with the Referees course, it gives us 890 people who have benefited, through the introduction of a National Coaching Scheme. Averaging 33 per month or better than one a day since its inception.

The National Coaching Director, is also involved in the training of Goroka Teacher College Physical Education Students.

These students complete a course in Rugby League Coaching and Refereeing as part of their Physical Education training. This gives rugby League the very same opportunity as other sports in schools and give pupils in Schools

where these Students are posted, the advantage of learning the skills and techniques of rugby League, from qualified people and also learn mini-games that can lead them into Rugby League well equipped to play the game at all levels. Schools Boys, Junior League plus Senior Rugby League.

The National Coaching Scheme.

Has been involved in, conducting Clinics for young people interested in rugby League, over 700 have attended these. Also coaching Forums involving Referees Coaches and players where all aspects of Rugby League have been discussed, from Administration to Ball Boys.

The National Coaching Scheme, is contributing to Rugby League in Papua New Guinea and hopefully it will be allowed to continue, for a second and third term, to reach the ultimate goal for which it was established.

Keith Collins
PNG Rugby Football League
National Coaching Director



Wau - Bulolo league getting stronger

RUGBY League has been a sport that was introduced in Papua New Guinea during the time of the Australian Administration and where there was a white community their grew a community which put the code into practise.

One such in Papua New Guinea is Wau and Bulolo.

The names of some of the early players and officials in the early 60's: Bob Murphy, Bill McKenzie, Bill Phillips, Bobby Ackerman, John Trevor, Jack Lindquist, Eric Boyd, and his Brother Charles Boyd. Peter Holmes, Dave Smith, Len Price, Mauri Smith, Jim "Chimbu" Anderson, and Dr Kelly Larkin.

Apart from the expatriates there was also nationals who can be called pioneer of the game in that area, such were Komo Aihi, Daniela Gire, John Dobi Roroa Maru, John Chacker and Kalep Kawa, (now the provincial member for Bulolo).

In those day's the competition was low key and there were not many representative games

However in 1966, Maurie Smith and Komo Aihi were selected and were able to play for the New Guinea side against Papua.

Most of the players were employed by the Bulolo Gold Dredging however the league died a natural death in 1968 when players began to move out of the area.

But in 1970 and 1980 the league was started up again.

In 1981 - Mr Franz Arentz was elected the president of the Wau-Bulolo league.

In 1982 Mr Brian Sullivan took over as president of the league and in 1983 Mr Kone Henry was

elected president of the league.

"I found it very hard to run the Wau-Bulolo league says Kone. Firstly because there was not enough players and also that because of financial problems due to a small number of players in the competition it was hard to bring up the standard of Rugby League, because the games were played on and off.

However, this year a number of good players some of which have experienced playing in major centres like Port Moresby like Peter Bebi, Gima Ai, Michael Noah, and Mathias Vineval were able to boost the interest of the league in the centre.

And this year the Wau-Bulolo league was recognised as an associated member of the PNGRFL because of the late payment of their affiliation fees.

Since Wau-Bulolo league was not able to compete in the northern zone trials Wau Bulolo have played their own test matches between the

Ramu.

The development of the Wau-Bulolo league here is growing very fast and it is fortunate that the game of Rugby League now is gaining full support of the community and from individuals within the community who are dedicated in developing the code.

The league's only major problem is the oval is not fenced and therefore there is no revenue.

The Wau Oval was recently fenced by the Provincial government but the oval is also being shared with soccer games

Mr Henry, however, said there needed to be two ovals built one in Wau and the other in Bulolo specifically for the use of Rugby League

"I say this because these two communities here in Wau and Bulolo have players who are just as good as players in other centres. I also believe that players have both the spirit and the morale in developing the league in Wau and Bulolo



Rugby league news acknowledges

AS we remember the occasion of our independence, we think of people who have contributed much towards it achievement.

People like Michael Somare, Moaori Kiki, Julius Chan and company. Likewise in rugby league we think of people like Jim Jacobi, Jeff Wall, Ben Sabumei, Kevin Murphy and company for making rugby league the greatest game of all in Papua New Guinea today

But most of all, we are forever conscious of the stars of rugby league and forget about the "little people" behind the scenes whose efforts have contributed to the development of rugby league over the past ten years.

As our independence fathers receive medals for distinguished services and contributions to national development, we at Rugby League News acknowledge the following for their services and contributions to rugby league

R Albert, K Kearsley, J Amesbury, V Murphy, O Fischer, A Vaname, D Yates, S Bonga, D Mea, N Nicholson, D Downie, P Betson, P Jeffs, B King, P Repatraio, L Pascoe, J Colwell, D Klink, J Collin, P Mullins, A Malori, B Middlemiss, B Humphries, P Aia, P Aisa, J Kevime, G Ainui, R Stewart, R Seymour, L Pettitt, E Baal, G Ainui, T Riles, the late Dr S Tongia, G Cooper, R Cutmore, T Peruka, M Adamson, K Haiveta, S Palanga, B Noi, I Jorgensen, J Taylor, R Anderson, H Greer, M Firth, M Seeto, T Lavatul, J Weise, R Wilkes, A Straube, B Van Heekeren, J Nitsche, Lloyd Robson, Rod Pierce, Dawa Solomon and not forgetting members of the press.

Those who have contributed either directly or indirectly, we acknowledge your efforts also. On this occasion, it is only fair that rugby league doff their hats to you all for making rugby league what it is today

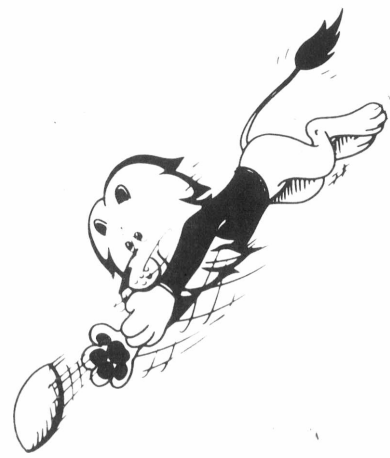

POINTS TABLE

SPONSORED BY
WILLS
TOBACCO LTD



WILLS TOBACCO LTD

LAE

1985 PREMIERS
"A" GRADE
SULLIVAN DEFENCE

"B" GRADE
SULLIVAN DEFENCE

MADANG

"A" GRADE
PREMIER
TIGERS

TARI LEAGUE

1985 PREMIERS
"A" GRADE
J.D. PANTHERS

"B" GRADE
BROTHERS

NATIONAL CAPITAL

1985 PREMIERS

"A" GRADE
BOMANA

"B" GRADE
BOMANA

"C" GRADE
BOMANA



● Thank you Mr Rosanoski I think Bomana deserves this shield.

N.C.R.F.L grand final action

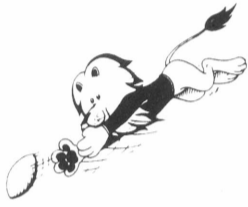

● Bomana for 85'. Bomana supporters saluting their first grandfinal win.



● You better get down is what this Saraga player is saying.



● Hey no punching guys.



● That's right brother it's almost on the bridge of my nose.. that's Ray Mitton being checked a tough centre.



● Well at least I'm on the upper end.



● Well another one bites the dust.

Port Moresby League Action

Pictures by Mark Roi Teno

● Port Moresby's top referee Graham Ainui under pressure at the grandfinals. Well I guess it's all over for the time being.



Hobar West Trainer Samuel Susuve scored his first win as a trainer in Rugby League "I feel absolutely terrific".

● A reserve grade defence player seems to be caught in this Paga defence.



● Well mate I guess we'll be going down together.

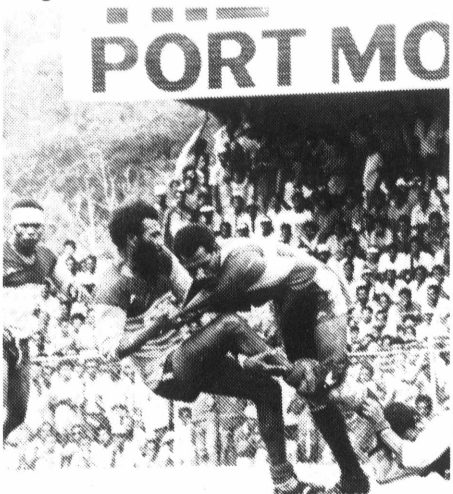

● Hey bras yu painim wanem nau?



● Let me go you damn leech.

Rugby League Uniforms

17 JERSEYS
17 SHORTS
17 SOCKS
17 NUMBERS

ONLY K450

Choose from **13 DIFFERENT STYLES** from SYDNEY CLUBS!

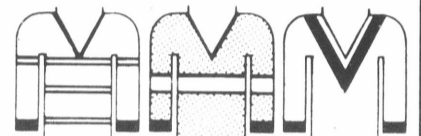

Maroon White Marilyn Sky Black/White Cronulla White/Red St George

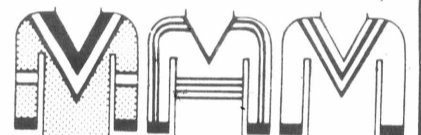

Navy Red White Eastern Royal Blue/Gold Parramatta Orange/Black Balmain



Red Black North Royal Blue White Canterbury Royal/White Newtown

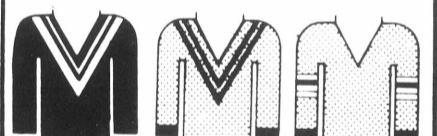

Black/White Western Green/Gold Australian Lime/White/Royal and Gold Canberra

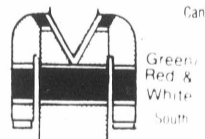

Green/Red & White South

TOP QUALITY UNIFORMS IN STOCK NOW FOR IMMEDIATE DELIVERY!



PORT MORESBY, LAE, RABAUL, ARAWA, GOROKA, TABUBIL, KIMBE, KIETA

For orders and enquiries phone: MIKE CARTER 217799 BARRY BARRY 217322 Pom DAAN or BONI 422213 Lae CEDRIC 922039 Rab

Please send information on

NAME

ADDRESS

PHONE

or write to P.O. Box 1141, Boroko N.C.D.

Prices do not include cost of freight from Port Moresby.

league Mettas

SUNDAY'S grandfinal was certainly a thriller and would have been better if not for the rain.

The K-Aves, I understand are still celebrating West 14-0 grandfinals win over Air Niugini.

It's amazing how our superstitions play a big part in our lives, even in sport.

Notice Air Niugini did not touch the ball from the kick off by Wests. I heard that the ball was put through some Kerema magical work, what ever that means.

But that aside, congratulations to both Air Niugini and Wests and especially to West for bagging the premiership for the third time.

Congratulations also goes to Defence of Lae for taking out their first ever premiership and to all other clubs throughout the country for wins in their respective leagues.

A league goer was arrested at Lang park recently, and was fined \$75 in the Brisbane magistrates court because he had Queensland police badges sewn on his leather jacket.

He pleaded guilty, but said that is uncle had given him the badges. A check through the records showed that the uncle had been convicted of impersonating a police officer.

Talking about cops, heard about the lady driving down Moresby road, steering her car with her knee, as she knitted. A policeman pulled alongside and shouted, "Pull over, lady." She replied: "No, its a cardigan for my husband."

Making a break from the lunatic assylum and brandishing an iron bar the escapee commanded a chinese laundry run and forced the two orientals to drive hellbent to the country.

Unfortunately they came into violent collision with a freight train at a level crossing.

The ambulance recovered two washers and a nut.

Seen on a tombstone
Here lies a father of 29.
He would have had more
but he didn't have time

All the best to the teams playing during the independence anniversary week. May the best team. For the aspiring national reps, play your best. Whatever you do on the field, do it dilligently, in style and above all do it the Papuan New Guinean way.

Happy playing and celebration to one and all.
Take care Jack Metta.

ISLANDS tipped for first title

by BENNY BOGG

WE could cut our tongues for saying that Southern Zone was thrashed by Islands last Tuesday night during the start of the zone championships, because some of the key players in the Southern Zone team were still recovering from last Saturday's Port Moresby grand final.

Rugby League in its many years of receiving quite a lot of attention in PNG should have prepared zone selectors and players and there need not be any

excuses for physical and medical fitness for players selected to participate in the second biggest league competition in the land.

Thanks to the selectors and administrators in the Island region. Their selection has proved a success on Tuesday when Island displayed a 'give-no-and-take-no-quarter' match over last years champion Southern Zone and easily won by a 20 points margin; 26-6.

I could come close to the truth when I say

that this year could be Islands' number one in the history of zone championship. But as I see it, Islands will take on Highlands in the grand final.

Highlands defeated Northern 28-4 on Tuesday. A much improved Northern Zone backline fired to notch the first four points but a more determined Highlands pack diminished all hopes for Northern's victory.

The score at half time suggested a hard fought match. Highlands' 12-4 led at the half way mark is read parallel to Islands' 14-6 half time score against Southern Zone. Both scored eight points more than their rivals.

The vital match for Highlands and Islands yesterday is a landmark for Island's Zone since 1975. From here they will never look back.

Since 1975 Southern Zone have been masters in race of zone trials. From 1978, Highlands took over Southern again in 1981.

Highlands in 1982 and from 1983, its been Southern Zone all the years after. It tip Islands

ZONE TEAM LINE UP

SOUTHERN ZONE

- 1 Mathias Kitimon
- 2 Alan Aukoa
- 3 Peter Evara
- 4 Mafu Kerekere
- 5 Kwapena Vagi
- 6 Gesau Gebob
- 7 Tony Kila
- 8 Gideon Kouoru
- 9 Joe Madidu
- 10 Kile Ario
- 11 Henry Miro
- 12 Roy Heni
- 13 Tati Ivava
- 14 David Noifa
- 15 Bernard Waketsi
- 16 Alois Erebebe
- 17 Joe Wate
- 18 Ray Mitton
- 19 Anderson Agiru
- 20 Heni Morea

Coach Clive Clerke
Manager Tony Huai
Trainer Buddy Dou

NORTHERN ZONE

- 1 Julius Casey
- 2 Sam Kawari
- 3 Simon Elap
- 4 Alphonse Malala
- 5 Harry Tambui
- 6 Andrew Gandin
- 7 Peter Metta
- 8 Joe Katsir
- 9 George Kua
- 10 Tua Amuino
- 11 Dekot Koki
- 12 Michael Matmillo
- 13 Aiyuta Ayako
- 14 Lawrence Koko
- 15 Kimoi Koiwa
- 16 Andy Ralpa
- 17 Albert Aigwy
- 18 Benjamin Kimisive
- 19 Peter Barbs
- 20 Jorifa Yubiko

Coach Peter Bananga
Manager Tom McEnroy
Trainer Gavin Ross

HIGHLANDS ZONE

- John Koniara
Arnold Tivilet
Dickson Kimi
Bal Numapo
Mawe Kaupa
Ifisoe Segeyaro
Collin Bahilio
Pora Wek
Robert Kubak
Bobby Ako
Phillip Ralda
Ken Kemutafe
Brown Sil
Ifisa Wanenga
Joe Tep
Sam Karara
Mol Apa
Tom Panu
Homate Payesi
Peter Launa
7
Joe Mugabuga
Himony Lapiso
Karo Kamu

ISLANDS ZONE

- Kungan Kuvuu
Kama Nalus
Jimmy Peters
Petrus Lalio
Abel Tulai
David Tommy
Ngala Lapan
Ekon Togili
Joe Gispe
Nelson Iune
Peter Kilori
John Polup
Simon Wema
David Gaius
Darius Haili
Michael Losah
Penias Wasiton
Austin Reddy
Simon Benari
Jack Sapat

John Kolan
John Mark
John Robin

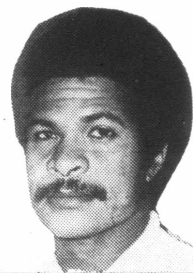

from the EDITOR'S desk

So long and all the best

TO ALL league clubs throughout the country Rugby League News would like to congratulate all the teams who have taken out their hard fought premiership awards.

This year's league season was a very hectic one especially to all the teams that tried their best to at least put up some strong resistance.

RLN also would like to thank the club executives for their unending support to their players supporters and especially to the greatest game of all.

Our season has finally come to an end and for our loyal supporters it will be a game they will miss. But remember that next season, we hope that you will be still supporting the greatest game of all because Papua New Guinea will be heading for big things.

1985 has surely been a year where many leagues can boast that they have gone one step ahead.

Finally Rugby League News would like to wish every one a happy Tenth Anniversary.

And next year we hope to eclipse the whole of Papua New Guinea in order to produce a bigger and better paper. Until next season, take care and all the best!

Yours in Rugby League

ALFRED KANINIBA

Defence's big deal!

ELA Motors has announced a comprehensive sponsorship package totalling K10,000 for the 1986 Port Moresby Rugby League Season for the Toyota-Defence Rugby League Club at a function hosted by Lt. Col. Vagi Mai, president of the Toyota-Defence RFL Club and Senior Defence Force Officer with Brigadier - General Ken Noga in attendance to officially accept the Sponsorship Agreement from Ela Motors Advertising and Marketing Executives.

Also in attendance was Lt. Alois Erebebe - Port Moresby's Rugby League 'Player of the Year' and retiring 'A' Grade Coach Jim Taylor.

Ela Motors, who are official sponsors of Port Moresby Junior Rugby League for the next 5 years, will be continuing their sponsorship of the entire Defence Force Rugby League Club in all Grades (Under 17's, Under 19's, 'C' grade, Reserve grade and 'A' grade) for the 1986 season.

* Brian Taylor, personnel manager of Ela

Motors who was standing in for his Divisional Manager, Adrian Collins, who was out of town and not able to be in attendance at the function, said in presenting the sponsorship agreement to Brigadier-General Ken Noga that Ela Motors and Toyota, who came together with the Defence Rugby League Club in 1985, were proud to be associated again for 1986 and with closer support by the Ela Motors executive team he was sure Toyota-Defence teams would be in the winners circle towards September next year.



JOHNSTON'S PHARMACIES

PLAYER OF THE WEEK!



Ray Mitton
inside centre
Bomana Club
NCRFL

Congratulations!

You win K20 worth of First Aid accessories for your team from Johnsons Pharmacy



FOR ALL YOUR FIRST AID!

FOR HEALTH & FITNESS

SPONSORS
WEIGHTLIFTING
IN P.N.G.

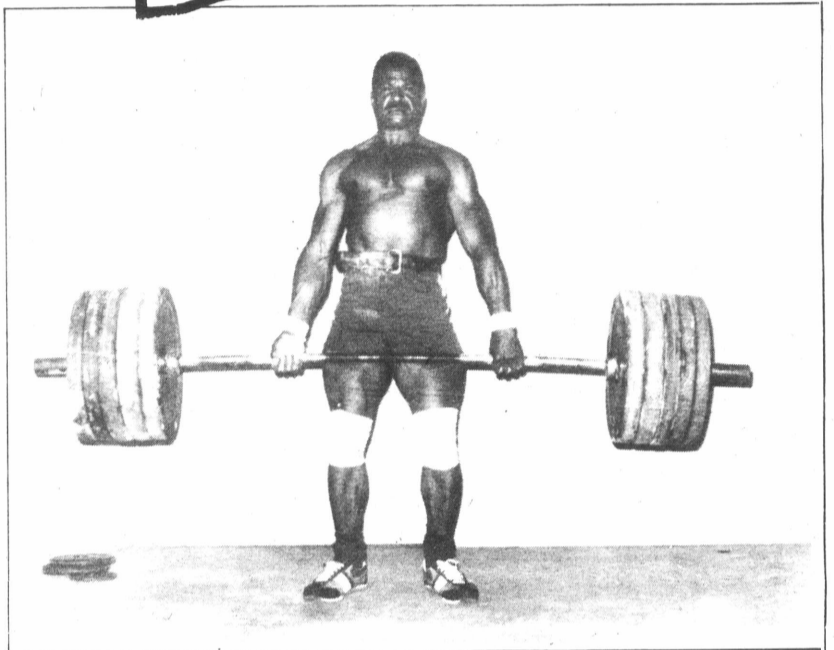
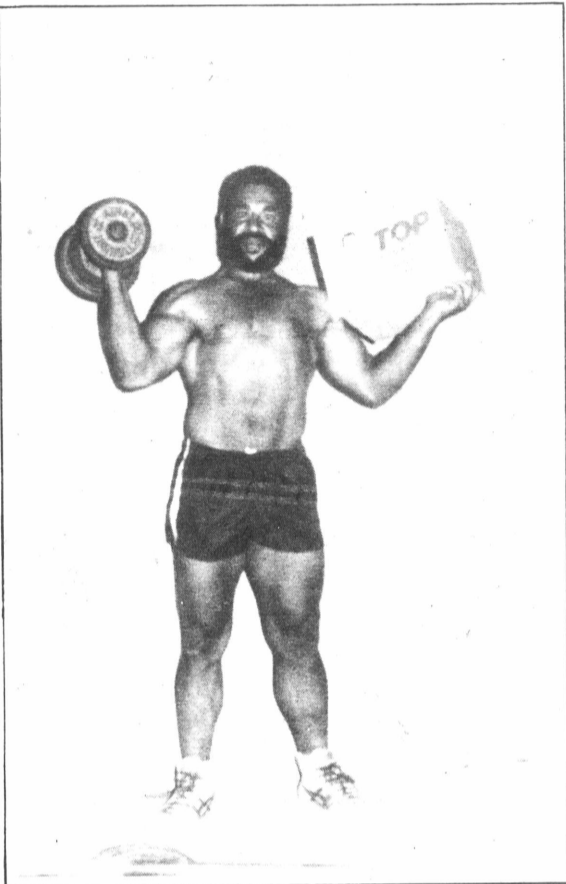

A team of eleven competed in the Australian Powerlifting Championships held in Brisbane, the team consisting of Barry Hughes Manager, Michael Mexico Coach, Roy Yali and Danny Pakalu Officials (to gain referee experience) Tias Tuna, Michael Matsi 60kg Division, Jacob Kuila, Jwila Jacobs 67.5kg Division, Linus Hopabul, Doasa Kobusu 75kg Division and David Teiko 82.5kg Division.

As guests of Australia the team could not win any titles but the performance of our lifters impressed and surprised the Australian Officials that much that the lifters were presented with awards.

Papua New Guinea can be assured of our future in this sport after the Australian Officials complimented the team on their World Standard. Michael Matsi and David Teiko were most outstanding in their Divisions.

B. HUGHES

06th September, 1985

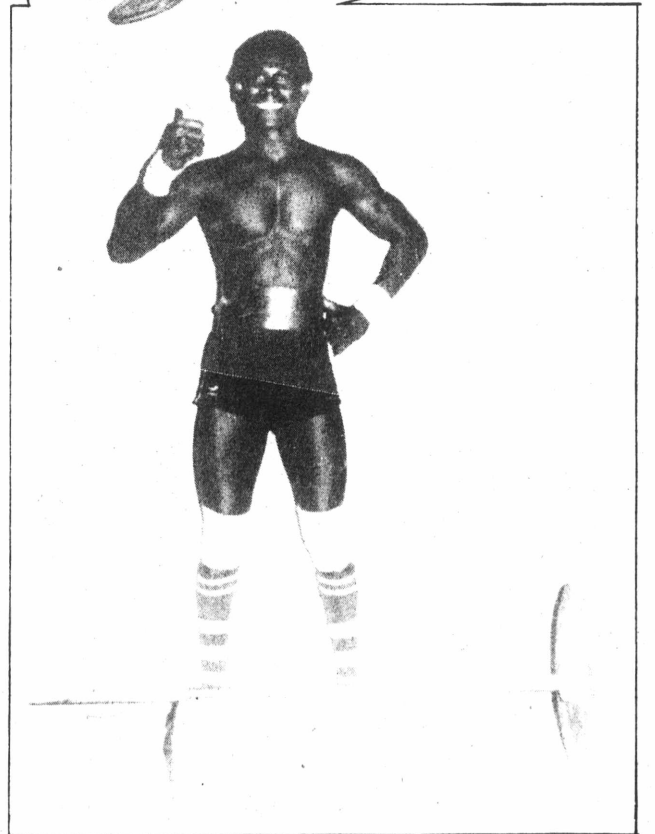
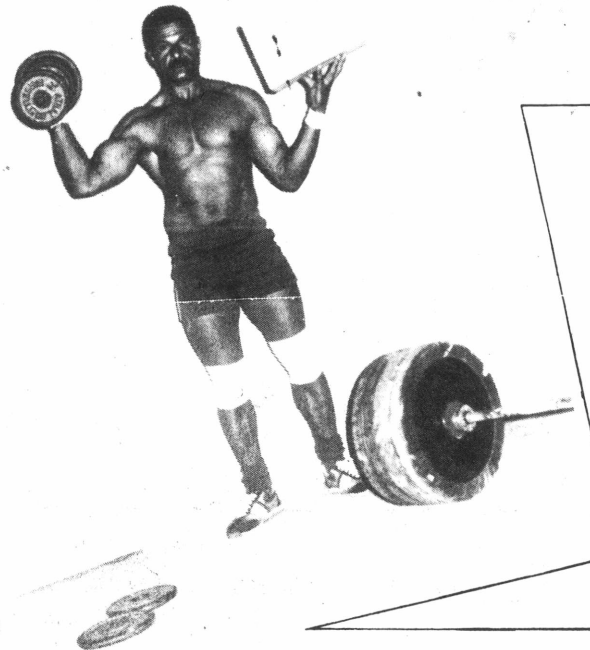

HE'S WON

K500 CASH

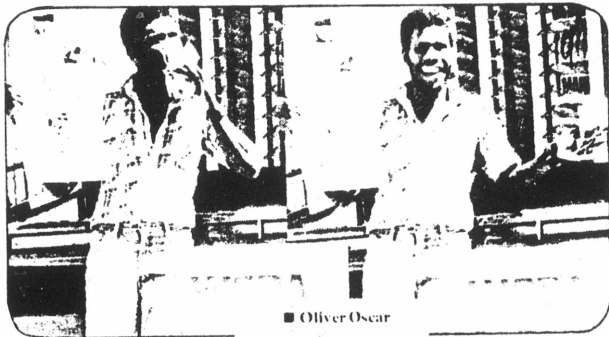

Oliver Oscar

WILL YOU?

EVERY WEEK K500 CASH TO BE

WON

SPOT THE BALL

Only in Wantok



EDUCATION MEASUREMENT SERVICES

PAID CERTIFICATES

Original Statutory Declarations which
 Certificates are no longer in the
 possession. Official Statements of
 replace these certificates. Any use
 of issue of the replacement is
 suspect.



PAMOTU BENEDICT	KEREVAT HIGH SCHOOL	1971	16/04/85	KOKON JACK	MADANG TECH COLLEGE	1977	12/07/85
HEMBENEI WILSON	MADANG TECHNICAL COLLEGE	1976	16/04/85	MABU LEVI	MENDI HIGH SCHOOL	1977	12/07/85
KADAKA GORRETTY	MALABUNGA HIGH SCHOOL	1975	16/04/85	TABULO ANDREW	PALMAMAL HIGH SCHOOL	1978	12/07/85
JOHN ESSON	FATIMA HIGH SCHOOL	1976	16/04/85	NONO MOREA	BADHAGWA HIGH SCHOOL	1978	12/07/85
SIBE LAWRENCE	HAGITA HIGH SCHOOL	1975	16/04/85	WINKUARU ISIDORE	MAPRIK HIGH SCHOOL	1978	12/07/85
MASIU LUKE	RIGU HIGH SCHOOL	1981	30/04/85	ALAPE DAMIEN	GOROKA TECH COLLEGE	1977	12/07/85
WOFUMBI KUTAP	DREGERHAFEN HIGH SCHOOL	1982	30/04/85	MATSU JOSEPHINE	OLSH HIGH SCHOOL	1978	12/07/85
NAURU DOROME	KEROWAGI HIGH SCHOOL	1980	30/04/85	KAUPA KIA	IAROWARI HIGH SCHOOL	1978	12/07/85
IMAMA EVA BONA	DE LA SALLE HIGH SCHOOL	1975	30/04/85	WALLOK DAVID	PAUSA HIGH SCHOOL	1979	12/07/85
URE BEA	O.L.S.H HIGH SCHOOL	1981	30/04/85	WALI MOSES	RABAU HIGH SCHOOL	197	12/07/85
TIKA YANA	BUGANDI HIGH SCHOOL	1971	30/04/85	LUTHER JOSEPH	WABAG HIGH SCHOOL	1981	12/07/85
SIWER ROBERT	KAMBUBU HIGH SCHOOL	1979	30/04/85	KYANGALI DIAKALI	PAUSA HIGH SCHOOL	1981	12/07/85
DEDEWANA GILO HEDRICK	BADHAGWA HIGH SCHOOL	1977	30/04/85	GALUS MERAM	MAPRIK HIGH SCHOOL	1981	12/07/85
ABABA LUKE	LAE TECHNICAL COLLEGE	1975	30/04/85	PARINDALE LIBE	TARI HIGH SCHOOL	1981	12/07/85
NAMBANAMA JOHN	MARTYRS HIGH SCHOOL	1984	15/07/85	KEPUTONG JEREMIAH	BUMAYONG HIGH SCHOOL	1982	12/07/85
PITIRI NAWI	KOROKA HIGH SCHOOL	1984	15/07/85	SEIWENI DANIEL	LUMI HIGH SCHOOL	1982	12/07/85
KEVIN PATONGIEL	MALAGUNA TECH COLLEGE	1977	15/07/85	KUKUP JULIUS	BOISEN HIGH SCHOOL	1982	12/07/85
TAPAI YALYA	PAUSA HIGH SCHOOL	1983	15/07/85	IPA SARUFA	KAMBUBU HIGH SCHOOL	1982	12/07/85
KUNALISA SAKIS KUN	LAIAGAM HIGH SCHOOL	1984	15/07/85	MORIS GEROLD	LUMI HIGH SCHOOL	1983	12/07/85
YUBIRAGO HAYABE	KOROKA HIGH SCHOOL	1983	15/07/85	TROGI HARRY	MARTYRS HIGH SCHOOL	1983	12/07/85
NEPAO NERKY	PAUSA HIGH SCHOOL	1977	24/07/85	DIDE PAULINE	POPONDETTA HIGH SCHOOL	1983	12/07/85
SKUB MICHAEL	MADANG TECH COLLEGE	1977	24/07/85	YKONGRI YAPOWA	KOMBOLOPA HIGH SCHOOL	1983	12/07/85
RAWO STEPHEN	BRANDI HIGH SCHOOL	1975	24/07/85	WALI MOSES	RABAU HIGH SCHOOL	1979	15/07/85
MESSA ANDIWA	DARU HIGH SCHOOL	1980	24/07/85	IODEME UMAGU	GOROKA HIGH SCHOOL	1984	15/07/85
SIGIMO ATIO	BENABENA HIGH SCHOOL	1980	24/07/85	JAKE BEN	KILAKILA HIGH SCHOOL	1984	15/07/85
AUL TOM	LAIAGAM HIGH SCHOOL	1981	24/07/85	JOHNSON JOEL	GELEM HIGH SCHOOL	1975	30/04/85
KORA MANI	MUAINA HIGH SCHOOL	1982	24/07/85	KUMAN PIKIP JOSEPH	KEROWAGI HIGH SCHOOL	1980	30/04/85
TAKURA BAPI	WABAG HIGH SCHOOL	1982	24/07/85	TAMAN ELIAP	BOISEN HIGH SCHOOL	1982	30/04/85
ONAMBO LINDSAY EDWARD	MARTYRS HIGH SCHOOL	1973	24/07/85	RANIATA REA	LAIAGAM HIGH SCHOOL	1983	30/04/85
EBES MEKALYN	MADINA HIGH SCHOOL	1977	24/07/85	JOHN WILLIE	TUSBAB HIGH SCHOOL	1983	30/04/85
KANDATO YOMBONAKALI	PAUSA HIGH SCHOOL	1974	24/07/85	PATRICK WALDO	BUGANDI HIGH SCHOOL	1983	10/05/85
EMAINO MAMAU	MT. DIAMOND HIGH SCHOOL	1984	24/07/85	VAGI KALA	KILA KILA HIGH SCHOOL	1983	10/05/85
YANGA RUBEN PEA	PANGIA HIGH SCHOOL	1984	24/07/85	STEVEN ALLAN	WESLEY HIGH SCHOOL	1983	10/05/85
BIGE PAUL	MUAINA HIGH SCHOOL	1984	24/07/85	NAKON MARIA	MADINA HIGH SCHOOL	1982	10/05/85
CAPI PAU	KWIKILA HIGH SCHOOL	1983	24/07/85	MUNDUA DINBI	KEROWAGI HIGH SCHOOL	1981	10/05/85
PANI WILLIAM	ST. XAVIERS HIGH SCHOOL	1983	24/07/85	ANTON ALO	PAUSA HIGH SCHOOL	1981	10/05/85
TILDO PELE	MENDI HIGH SCHOOL	1983	24/07/85	PALIE POKOPIYE	MT HAGEN HIGH SCHOOL	1981	10/05/85
RUABA NIGEL	POPONDETTA HIGH SCHOOL	1976	24/07/85	MUI GERE	CHUAVE HIGH SCHOOL	1981	10/05/85
OK BAREK	MINJ HIGH SCHOOL	1984	24/07/85	NAPAE PARENK	WABAG HIGH SCHOOL	1979	10/05/85
WAK STEPHEN	MOUNT HAGEN HIGH SCHOOL	1984	30/07/85	TALIUAN PAUL	PALMAMAL HIGH SCHOOL	1979	10/05/85
MIMARI JEAN MADLINE	DOGURA HIGH SCHOOL	1979	30/07/85	IAPIA RANIATA	AITAPE HIGH SCHOOL	1975	10/05/85
NUGI TIMBI	MADANG TECH COLLEGE	1971	30/07/85	WEKUL DANIEL	RABAU HIGH SCHOOL	1975	10/05/85
DIMO THOMAS	HAGITA HIGH SCHOOL	1980	30/07/85	DANIEL JILL	MARIANVILLE HIGH SCHOOL	1975	10/05/85
VARBALAI STANIS	KOKOPO HIGH SCHOOL	1976	30/07/85	PALA ILA	KWIKILA HIGH SCHOOL	1972	22/05/85
BATU SALE	GOROKA TECH COLLEGE	1978	30/07/85	MIVA TOM	PORT MORESBY TECH COLL	1976	22/05/85
ANGAIWA MEKENG	MALALA HIGH SCHOOL	1975	30/07/85	PAUL KIAK	MADANG TECH COLLEGE	1973	22/05/85
RAINO STEPHEN	BRANDI HIGH SCHOOL	1975	30/07/85	HARO MEROVE	MARIANVILLE HIGH SCHOOL	1978	22/05/85
RABBIE ROBIN	KOKOPO HIGH SCHOOL	1982	30/07/85	KEI POREAPO	KAGUA HIGH SCHOOL	1979	22/05/85
GALA GOMADA	AWABA HIGH SCHOOL	1982	30/07/85	ILOT RAPHAEL	BOISEN HIGH SCHOOL	1980	22/05/85
GAMBA JOSEPH	HOSKINS HIGH SCHOOL	1980	30/07/85	YALYA KUTEA	ARAWA HIGH SCHOOL	1981	22/05/85
ALAVA CLEMENT	IAROWARI HIGH SCHOOL	1980	30/07/85	KIRAI HANSEL	MARTYRS HIGH SCHOOL	1983	22/05/85
NUANA MUDIRI	IAROWARI HIGH SCHOOL	1978	30/07/85	KORAK KAPU	WABAG HIGH SCHOOL	1980	29/05/85
PAITO MOHAE	BUSU HIGH SCHOOL	1979	01/08/85	HUVE NAGATUMO	GOROKA HIGH SCHOOL	1975	29/05/85
PAIPAIRA MAY HILDA	DOGURA HIGH SCHOOL	1973	01/08/85	LAE MARAI	MALALAU HIGH SCHOOL	1978	29/05/85
AKAKU IAMO	KILAKILA HIGH SCHOOL	1978	01/08/85	KAIRI PAMATA	KEREMA HIGH SCHOOL	1975	29/05/85
WAUTA DAVID	BOISEN HIGH SCHOOL	1981	01/08/85	UAKU JOHN	VUVU HIGH SCHOOL	1976	29/05/85
WALAUNIA ELIZA	KIMBE HIGH SCHOOL	1978	01/08/85	ANTONIO WYCLIFFE	WESLEY HIGH SCHOOL	1976	11/06/85
BURUA LELEOK	MALABUNGA HIGH SCHOOL	1978	01/08/85	MANUEL EREMAS	UTU HIGH SCHOOL	1984	11/06/85
MAITAKULI PAKE	WABAG HIGH SCHOOL	1977	01/08/85	MALA LORAH	KAMBUBU HIGH SCHOOL	1981	11/06/85
THOMAS TEIA	PORT MORESBY TECH COLL	1976	01/08/85	EPHRAIM JAMES	LAIAGAM HIGH SCHOOL	1981	11/06/85
DIRITANUMO JOSEPHINE	DOGURA HIGH SCHOOL	1971	01/08/85	HENI KARI	KWIKILA HIGH SCHOOL	1981	11/06/85
POMAKI RENATE	MANUS HIGH SCHOOL	1969	01/08/85	UFAIO KWASI	MADANG TECHNICAL COLLEGE	1976	11/06/85
TERI JAMES	KILA KILA HIGH SCHOOL	1972	02/08/85	KETA BENI	DE LA SALLE HIGH SCHOOL	1977	11/06/85
GEI KEVIN	DELA SALLE HIGH SCHOOL	1973	02/08/85	NORI BETTY MAPA	NOTRE DAME HIGH SCHOOL	1978	11/06/85
PENROSE ALLAN	GORDON HIGH SCHOOL	1975	02/08/85	PEPE PAKUK	AITAPE HIGH SCHOOL	1979	11/06/85
TOABOLI PHILIPPO	KERAVAT HIGH SCHOOL	1974	02/08/85	TIRIMA FIRMAN	PANGIA HIGH SCHOOL	1984	11/06/85
HITOLO IGO	BADHAGWA HIGH SCHOOL	1974	197/06/85	MISEREL ALFRED	UTU HIGH SCHOOL	1984	11/06/85
GURIA ROBIN	KILA KILA HIGH SCHOOL	1972	197/06/85	RIFI MONCHIM	MARKHAM VALLEY HIGH SC	1984	11/06/85
SUNG BALAU	TUSBAB HIGH SCHOOL	1968	24/06/85	AWAROA IKAROA	IHU HIGH SCHOOL	1984	11/06/85
BINGMALOO PAUL	ASAROKA HIGH SCHOOL	1968	24/06/85	PARILIA WARUNI	TARI HIGH SCHOOL	1981	11/06/85
TAMI ALLAN	BOISEN HIGH SCHOOL	1975	24/06/85	KOIMA JOHN	KONDIU HIGH SCHOOL	1983	11/06/85
PONACN ESEKIA	ARAWA TECHNICAL COLLEGE	1976	24/06/85	DIAYA EPAGO	KAGUA HIGH SCHOOL	1983	11/06/85
EKI BONA	DE LA SALLE HIGH SCHOOL	1976	24/06/85	NUPRI NOLA	MENDI HIGH SCHOOL	1980	11/06/85
GAROKA HENRY	VUVU HIGH SCHOOL	1971	24/06/85	KAWAGE UKA	KEROWAGI HIGH SCHOOL	1979	11/06/85
BANDI SUPA	CHUAVE HIGH SCHOOL	1978	24/06/85	KOPO JOHN	BUN HIGH SCHOOL	1977	11/06/85
PIPI PAUL	DE LA SALLE HIGH SCHOOL	1978	24/06/85	DOTAGNA PERRY	CAMERON HIGH SCHOOL	1976	11/06/85
LARI MARGARET	MALALAU HIGH SCHOOL	1979	24/06/85	KOROTI VINCENT	MALALAU HIGH SCHOOL	1983	197/06/85
NIME WAU	KEROWAGI HIGH SCHOOL	1981	24/06/85	MERO BERNADETTE	KEREMA HIGH SCHOOL	1982	197/06/85
KOTERE ARTHUR	KUPIANO HIGH SCHOOL	1982	24/06/85	PONDRIEI MOLONG	MANUS HIGH SCHOOL	1980	197/06/85
LULUAI ARTHUR	BOISEN HIGH SCHOOL	1983	24/06/85	AUAPOK SUINA	BRANDI HIGH SCHOOL	1977	197/06/85
POLI LOREN	KAMBUBU HIGH SCHOOL	1983	24/06/85				
KUMORMAI SIBILAI	TUSBAB HIGH SCHOOL	1983	24/06/85				
ESAIWA ANGELO	WABAG HIGH SCHOOL	1984	24/06/85				
SERE METAHERA	MALALAU HIGH SCHOOL	1984	24/06/85				
SEKI UROHO	GOROKA HIGH SCHOOL	1984	24/06/85				
ORI FRANCIS	DE LA SALLE HIGH SCHOOL	1984	24/06/85				
IRU AKLU	PORT MORESBY TECH COLL	1973	11/07/85				
TAGAMA KEYANA	AWABA HIGH SCHOOL	1973	11/07/85				
JACOB KAIMA	HAGEN TECH COLLEGE	1975	11/07/85				
JOSEPH MANUEL	MANUS HIGH SCHOOL	1975	11/07/85				
USAKE NANAI	GOROKA HIGH SCHOOL	1975	11/07/85				
ISULEILEI JOLLY	HOLY NAME HIGH SCHOOL	1976	11/07/85				
AVES BATHOLOMEW	ST MARY'S VUVU HIGH	1977	11/07/85				
ORANGASI BENJAMIN	MANGGAI HIGH SCHOOL	1977	11/07/85				
IONAU BERNARD	ARAWA TECH COLLEGE	1977	11/07/85				
IRU ARLU	PORT MORESBY TECH COLL	1973	12/07/85				

If employment has been offered to any person in the list :
 (a) after the date quoted, and
 (b) on the basis of sighting the original certificate,
 then it is likely that either impersonation or forgery
 has occurred. Employers are advised to check.

S.G. ROKEINA
 Secretary of Education

GRADE 10 CERTIFICATES



Making movement easy

— Friction in cars

When a car's wheels turn they should push against the road. If they slip or skid then the car cannot move properly. So there should be a lot of friction for the tyres on the road.

The road and the tyres should not be oily or slippery. If they are like that the friction is reduced and the car cannot move properly.

* Replace a tyre if it is worn. New tyres let any water on the road get in the spaces in the tyre. Then the rubber can grip the tyre.

Special tyres are made to give a lot of friction in loose sand or mud.

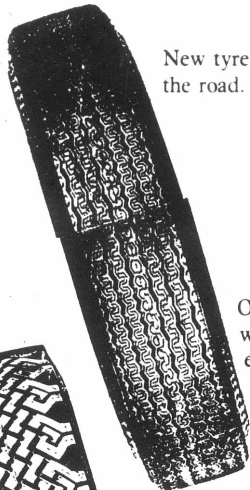

New tyre — grips a hard road well, even if some water is on the road. This gives a lot of friction.

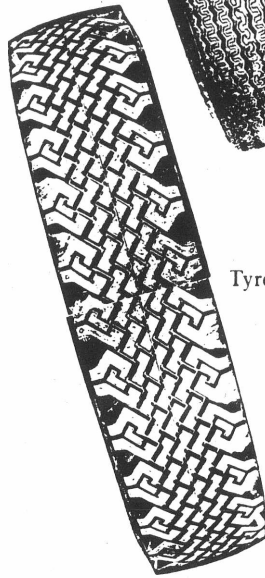

Tyre to give friction in sand or mud.

On an old tyre the rubber is worn smooth. If the road is wet the rubber will slide on the water — there is not enough friction.

Reduce friction in engines

Inside a car engine are parts which move. These parts must move easily past each other, so there should not be a lot of friction.

Oil is used to reduce friction in the engine as oil is very slippery.

- * The oil should be clean. Any dirt in the oil will rub on metal parts and make friction.
- * There must be enough engine oil for the moving parts. Oil is pumped around the engine to many of the parts. If there is not enough oil, some parts may have too much friction. They might then get worn away.

The parts inside an engine must move easily. They need oil.

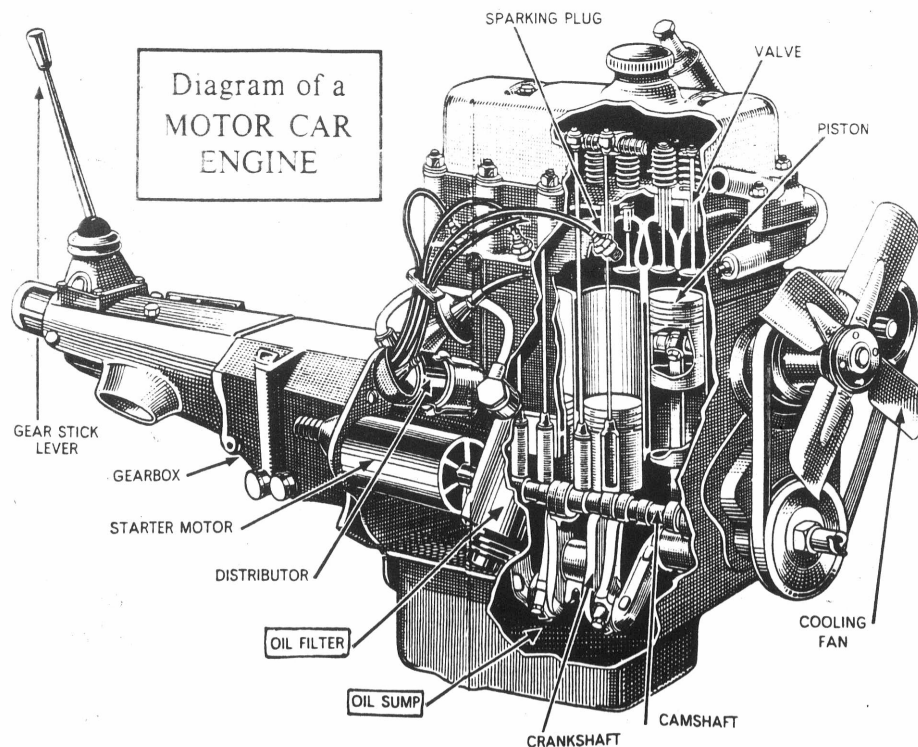

K500
Weekly
CASH
PRIZE

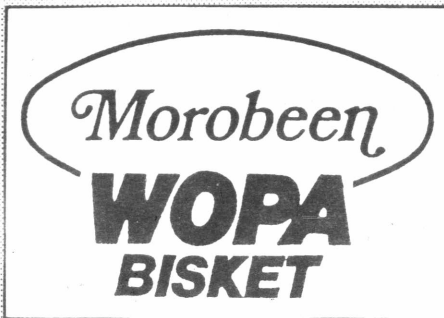

Look at the picture below. Put a X in the exact place where you think the ball should be using your skill and judgement. Cut out your entry along the dotted lines shown and fill in the special coupon alongside. Send your entry to,
Spot the Ball No.1
Wantok News.
P.O. Box 1982
Boroko.

SPOT THE BALL IS HERE!

SPOT THE BALL No 6



ENTRIES for Competition No 6 close on 4th October and all entries received after this date will not be accepted.



ONLY ONE X PER ENTRY. YOU MAY ENTER AS MANY ITEMS AS YOU WISH PROVIDED A SEPERATE COUPON IS USED

Rules and conditions of entry

1. The first correct entry drawn from the drum will be the winner.
2. Winners names will be published in Wantok newspaper the following week.
3. The judges decision will be final.
4. All entries must include an original entry coupon from Wantok newspaper. Photocopies will not be accepted and entries received after the closing deadline will not be accepted.
5. Employees of Word Publishing Co. Pty Ltd are not eligible to enter.
6. No correspondence shall be entered into.

**You can enter as many times as you want but,
 only one coupon per entry!**

Your Name

Your Address

Your Tel No.

The ball lies in square

Laik bilong ol yangpela

Dia Edita — Mi laik bekim toktok bilong Anton Yabisagi bilong Wes Yangoru, I.S.P. i bin kamap long Wantok Ogas 17.

Em i bin tok long rausim tok "SAISO". Mi wanpela yangpela man na mi no pilim orait long pas bilong em. Mi laik tok olsem

ating mobeta yu no ken subim nus raun long olgeta hap we ol yangpela manmeri i tok pilai i stap.

Sapos ol i wokim gris tok olsem "Saiso" na

"Ken ai o", em wari bilong ol. Dispela kain tok i bin bagarapim lewa bilong yu na yu tok o? No ken stapim laik bilong ol yangpela. Em wari bilong ol.

FKSPDA i go het

Dia Edita — Mi laik bekim toktok bilong Mista H. Hengune i bin kamap long Redio Morobe (15/8/85).

Em i bin daunim nem bilong Finschhafen, Kabwum, Siassi Planning and Development Authority (FKSPDA). Em i tok ol i no wok hariap long ol rot bilong Kabwum Distrik. Em i bin askim Primia Samana long putim tenda long narapela kampani i ken tek ova.

Gutpela man yu memba o wanem? Yu mas save olsem ples bilong yumi i gat taim bilong ren na taim bilong san olsem na FKSC i mas wok long taim tasol.

Sapos i ren long Finschhafen kampani i

mas i go long Kabwum o Siassi.

Bipo ol papa i laik brukim Morobe Provins i go tripela hap. Not Morobe, Saut Morobe na Sentral Morobe. Tasol taim Samana i kamap Primia, em i stapim ol papa na em i tok Morobe Provins em i no inap bruk.

Em nau ol i kirapim ol kain Autoriti olsem FKSPDA, Anga Development Autoriti na nau ol putim Huon Development Autoriti.

Mi ting Morobe Provins em i winim ol arapela provins long helpim ol rural pipel.

Maregbaroy Karapua, Kaiapit, Lae.

Peter K. Yakopa, RBK Viles, Kagua, SHP.

Givim I.D. kat long ol wokman

Dia Edita — Mi lukim planti hap long PNG ol skwata setelman long siti na taun i bagarap, tru. Olsem na long helpim liklik ol plisman mobeta yumi ol wan wan wokman bilong gavman na kampani i gat idetifikesen kat, (I.D. kat).

Dispela bai helpim ol plisman long save husat i trupela wokman. Na husat i drip nabaut i stap long ol taun. Ol pasin bilong stil na ol kain kain trabel i bagarap olgeta nau.

Moses Patage, Lae.

Wok i no ran gut

Dia Edita — Mi wanpela manki bilong Wemil viles long Nuku District insait long Wes Sepik Provins. Mi laik sapotim Mista Namah husat i memba bilong Bewanan long provinsal gavman.

Provinsal gavman

bilong Paul Langro husat i primia i no ranim gut wok bilong gavman inap 7-pela mun i go pinis nau. Na tu long taim bilong Primia Andrew Komboni em tu i no ranim

wok bilong gavman na politik gut long Wes Sepik.

Petrus Perkil, Wemil viles, Nuku, WSP.

Bilip long plis opisa

Dia Edita — Mi wanpela plisman i stap nau long Wakunai Plis Stesin long Not Solomons Provins. Mi laik givim bikpela tenkyu long plis opis, Mista David Iamerua. Em i stap nau long sampela hap bilong Kupiano Distrik long Sentral Provins.

Mi tenkyu long yu, Mista Iamerua. Long wanem yu wanpela man bilong wok hat na wok bung gut wantaim ol plisman bilong yu. Long taim bilong bikpela pait namel long tupela hauslain, man, yu save go pas long ol plisman na sanap namel. Na yu helpim long stapim pait namel long tupela grup bilong pipel.

Yu no save pret long ol spia i flai i go i kam. Olsem na mi bilip tru long olgeta bikpela na liklik wok yu bin mekim long ai bilong mi long Wapenamanda, Enga Provins.

Mi bilip bai yu go het long mekim dispela gutpela kain wok bilong yu. Tasol mi laikim ol hetman bilong Plis Dipatmen i lukluk long gutpela wok yu bin mekim long taim yu wok insait long ol Hailans Provins.

Nick Savalin Avene, F/Const. 4922, Wakunai, NSP.

Pas i lus long rot

Dia Edita — Plis givim liklik spes long mi. Wari bilong mi em i go olsem. Planti taim mi save salim pas i go

long ples bilong mi na mi save putim liklik wan siling long pas na mi save salim.

I tru mi save rejista o

tok lukaut long samt- ing i no ken lus.

Sapos taim mipela i save raitim leta na putim wan siling insait na go postim o long pos opis. Ating dispela leta i save putim tupela lek bilong em na i go paul pinis long namel na i no kamap long ples we mipela i salim.

Askim bilong mi i olsem bilong wanem tru na mani bilong ol pipel i save lus long pos ofis.

Turex guy, Bombx,



Tok Save i go long ol man i save salim pas long Wantok. Sapos yu no putim nem tru bilong yu long pas mipela i no inap prinim leta bilong yu.



NEW GUINEA MOTORS USED VEHICLES



STOCK NO. MODEL COMMENTS VALUE

PORT MORESBY

UVP413	Mazda Truck	1 owner	K2,000
UVP405	Daihatsu Poro	4x4	K2,500
UVP420	Toyota Ute	Unreal deal	K2,800
UVP418	Mazda 1600	Plenty rego.	K2,800
UVP423	Toyota Hi-Ace	15 seater	K3,000
UVP424	Isuzu BLD Bus	Ex PMV	K3,800
UVP416	Toyota Hi-Ace	Family unit	K3,800
UVP428	Isuzu SBR Truck	Automatic	K5,000

LAE

UVPL100	Isuzu 2.5 Tipper	Excellent condition	K2,500
UVPL128	Mitsubishi Canter	SWB, diesel	K3,500
UVPL144	Toyota Coaster Bus	Good PMV	K3,800
UVPL93	Suzuki Mini Van	Mag wheels	K3,800
UVPL142	Mazda B1600 Ute	New rego	K3,800
UVPL64	Toyota Stout Ute	Excellent mech.	K3,800
UVPL	Toyota Coaster Bus	Good PMV	K3,800
UVPL145	Nissan Patrol 4x4	Coffee body	K4,200
UVPL141	Isuzu BLD 36	25 seater	K4,500

MT. HAGEN

UVH—	Isuzu Twin Steer	16 tonne good unit	K2,500
UVH—	Nissan Patrol	1 Short wheel base	K5,000
UVH—	Nissan Patrol	1 Long wheel base	K7,500
UVH—	Isuzu Bus	1 year old	K7,500
UVH138	Hilux 4x4	3 months old	K8,500
UVH—	Toyota 6000	Tipper, good condition	K9,000
UVH—	Toyota 6000	Flat top, A1 condition	K9,000



Call in or phone us now!

HRD 6207

PORT MORESBY George Browne (91) 42 9644 LAE Norm Keay (91) 42 1477 KIEVA Doug Shortland (91) 96 1144 RABAUL Fred Powell (91) 92 1022 MT HAGEN Bob Hall (91) 52 1152 KIMBE Mark Seabrook (91) 53 7943 and TABUIL (91) 53 7943



Look what you can win in the Kodak 'Fun Taim' Photo Contest!

1. Grand Prize: Four FREE return Air Tickets!

Enter the Kodak "Fun Taim" Photo Contest and you could win the Grand Prize of Four Free Return Tickets to anywhere in New Guinea, flying Talair (two adults and two children). Entry Forms are automatically included in every 'Develop and Print' processing

order placed through the photo dealers listed below. Secondary prizes consist of 20 Kodak VR35 camera outfits, plus other prizes of Free Kodacolor Film for the next 100 successful entrants. It could be the most profitable way ever to celebrate the Anniversary!



TALAIR

2. FREE GIANT KODAK PENS!

Buy a roll of Kodacolor film now. You'll not only capture all the 10th Independence Anniversary fun,

but you'll also receive FREE a Giant Souvenir Pen. But hurry — offer while stocks last only.

3. FREE GIANT SOUVENIR WALL CHART!

Leave your color print film for processing with any of the dealers listed below, and you'll receive a Giant Souvenir Wall Chart, absolutely free! There's space

on the chart to mount your favourite pictures of the 10th Independence Anniversary fun! It will be a wonderful memory of the occasion in years to come.

All offers available from these Photo Dealers:

Port Moresby:
PNG Color Laboratories (Boroko, Gordons, Port Moresby)
Johnston's Pharmacies (Boroko, Gerehu, Port Moresby)
Haus Bilas (Boroko, Port Moresby—and other Haus Bilas stores in PNG)
Steamships (main Port Moresby store)

Lae: Lae Color Service
Morobe Pharmacy
Huon Gulf Pharmacy
Wewak: Wewak Pharmacy
Madang: Madang Pharmacy
Steamships
Mt Hagen: Mt Hagen Pharmacy
M & L Chegg
A J & S R Soo

Goroka: Goroka Pharmacy
Highlands Pharmacy
Steamships
Rabaul: Clarke's Chemists
Rabaul Pharmacy
Arawa: Johnston's Pharmacy
Arawa Supermarket
Panguna Supermarket

Kimbe: Kimbe Pharmacy
Kimbe Supermarket
Tabubil: Tabubil Pharmacy
Popondetta: Steamships

Free Giant Pen also available with Kodacolor film purchase from:
Chin H Meen (all stores); Tang Mow, Wewak; Wirui Trade Store, Wewak; Photo-Sonic, Madang; Wing Hay, Popondetta; JJ & H Seeto, Kokopo.

Sandaun independens wik

SANDAUN PROVINSAL gavman i opim namba wan de bilong amamasim Independens insait long Vanimo taun long dispela wik Trinde, 11 Septemba.

Spika bilong provinsal gavman, Mista Alphons Minda i opim dispela de bilong amamas long 10 klok moning. Na moa long 500 studen bilong olgeta komyuniti skul insait long Vanimo Distrik i bung long Vanimo spot oval. Planti papamama i kamap tu long lukim planti spot resis i kamap bihain long spika i opim pilai.

Mista Minda i tok spot pilai em i namba wan bikpela program bilong skulim studen bilong planti hap i bung na pren namel long resis insait long PNG na long arapela kantri tu. Planti ovasis kantri i luksave long PNG, bihain long spotmanmeri bilong PNG i winim resis insait long ol ovasis spot tonamen.

Em i tokaut olsem olgeta senta insait long PNG bai putim kamap bikpela spot resis bilong bungim pipel namel long dispela wiken bilong amamasim independens de. Na em i amamas tru long lukim dispela bikpela bung bilong ol studen tusa na papa-

mama long Vanimo. I gat soka resis namel long ol man studen na netbal resis bilong ol meri studen. Ol dispela resis i kamap namel long tim bilong wan wan skul long moning i go inap long 6 klok moning. Na i gat drama pilai i kamap long nait.

Ol dispela spot resis na drama nait bilong studen i pinis long dispela wok Fonde, 12 Septemba. Bikpela bung bilong ol bikpela manmeri bai kirap long dispela wik Fraide, 13 Septemba i go inap long Tunde, 17 Septemba. Bai gat spot resis bilong soka,

volibal, netbal na ragbi lig i kamap long Fraide i go inap Mande, 16 Septemba.

Long Sande, bai olgeta manmeri i bung gen long bikpela lotu sevis long 8 klok moning i go inap long 12 klok apinun. Na bihain bai spot resis i kirap gen i go inap long apinun tru.

Long Independens De (16 Septemba) bai gat draipela bung gen long Vanimo taun. Em i de bilong apim plak, singsing, bikpela wokabaut mas bilong Plis na skul studen na planti arapela pilai so. Bai gat spot resis na kain kain bung i kirap

long planti hap bilong taun.

Bai gat bikpela soka resis bilong Karl Stack Sil i kamap long Aitape namel long Fraide i go inap long Mande tu.

Soka tim bilong Vanimo, Aitape, Lumi, Nuku, Amanab, Bewani, Imonda, Grind Riva na Telefomin bai stap insait long dispela resis. Dispela spot resis long Vanimo na Aitape Distrik hetkota i stap namel long bikpela wiken bilong amamasim namba 10 Independens Yia bilong PNG long Wes Sepik Provins.

Ol memba i amamas long ol distrik

INDEPENDENS bung wantaim long Nu Ailan bai kamap insait long ol distrik na sab-distrik. Na bai i no inap long kamap long Kavieng taun tasol. Olsem ol i skelim pinis ol provinsal lida na memba bilong Nu Ailan Rijinal, Mista Noel Levi.

Primia yet, Mista Robert Seeto bai i stap long Is Kos eria, Kara/Nalik. Na provinsal seketeri bilong em, Chris Rangatin bai amamasim independens hia.

Primia Seeto i oraitim dispela program

long taim Nu Ailan Independens Komiti i bin askim em long skelim aut ol lida bilong em i go long olgeta eria bilong provins na i stap wantaim ol liklik lain pipel tru.

Mista Seeto i tok provinsal gavman yet bai painim rot bilong ol lida long i go aut long ol distrik. Bikos dispela K11,000 (11 tausen kina) Nesenel Gavman i givim long Nu Ailan bilong Independens amamas i no inap long bungim olgeta samting.

Long Kavieng taun bai i no gat bikpela selebresen tumas. Tasol long liklik distrik na sab-distrik komiti i wokim gut tru gutpela program. Program bilong Nu Ailan bai stat long Fraide, Septemba 13 i go inap long Tunde Septemba 17.

Na stat long Fraide bai ol wan wan provinsal memba na mimista bai i go i stap long ol 14 distrik na sab-distrik bilong Nu Ailan insait long dispela bung wantaim ol pipel na amamas.



Laitning Kilim Man

● Wapela man bilong Angoram, Is Sepik Provins i bin dai las wik bihain long laitning i bin kilim em. Man ya i bin ran long moto bot bilong em taim em i painim dispela birua.

Piis long Wewak i tok olsem dispela birua

i kamap namel long solwara. Olimekimyet wok painimaut long dispela samting.

● Tupela yangpela meri bilong Sepik i painim bagarap long las wik Sande long han bilong olstilman. Long Wewak, Is Sepik provins, sampela lain bilong stil long meri i

holimpas wapela yangpela meri, krismas 16, bihain long wapela danis long Wewak na bagarapim em. Plis long Wewak i tokaut olsem dispela birua i kamap long samting olsem 3.30 bikmoning long Sande 8 Septemba.

Long Lumi, Wes Sepik Provins, wapela man i bin holim pasim wapela haikul meri, 15 krismas, long haus malolo bilong haikul na bagarapim em. Dispela trabel i kamap long samting olsem 8 klok nait long las wik Sande.

The Coffee Market

Sponsored by:

COFFEE INTERNATIONAL
CIL PHONE 721322 P.O. BOX 111
 TELEX 72663 GOROKA
 FAX 722180 PAPUA NEW GUINEA

Wik stat long: 9-9-85.

Pe bilong grin bin kopi long ol stua long Lae na long ol dua bilong faktori.

Dispela mak bilong pe i kam long ol kopi kampani. Ol mak bilong pe i bilong wanwan senta insait long PNG.

Gret	Mak bilong Pe
Y _____	K2 15 inap K2 33
X _____	K2 20 inap K2 31
A _____	K2 25 inap K2 37
ROBUSTA _____	K2 00 K2 02

Pe bilong ol drai kopi bin long dua bilong faktori:

KAINANTU _____	K1 50	K1 52
GOROKA _____	K1 50	K1 61
KUNDIAWA _____		K1 45
MINJ. BENZ _____	K1 60	K1 65
Maun Hagen _____	K1 47	K1 49
WAPENAMANDA _____		K1 45
MENDI _____		K1 40
LAE Arabica _____	K1 50	K1 60
Robusta _____	K1 20	K1 30
MADANG Arabica _____		K1 40
Robusta _____		K1 20
WEWAK Robusta _____	K0 90	K1 00

The Future of our Country

depends on the health of our people.

For over 34 years, Johnston's Pharmacies have provided the people of Papua New Guinea with the latest medicines, chemist services and general health care products. We congratulate PNG on its 10th Anniversary of Independence and look forward to many healthy generations to come.

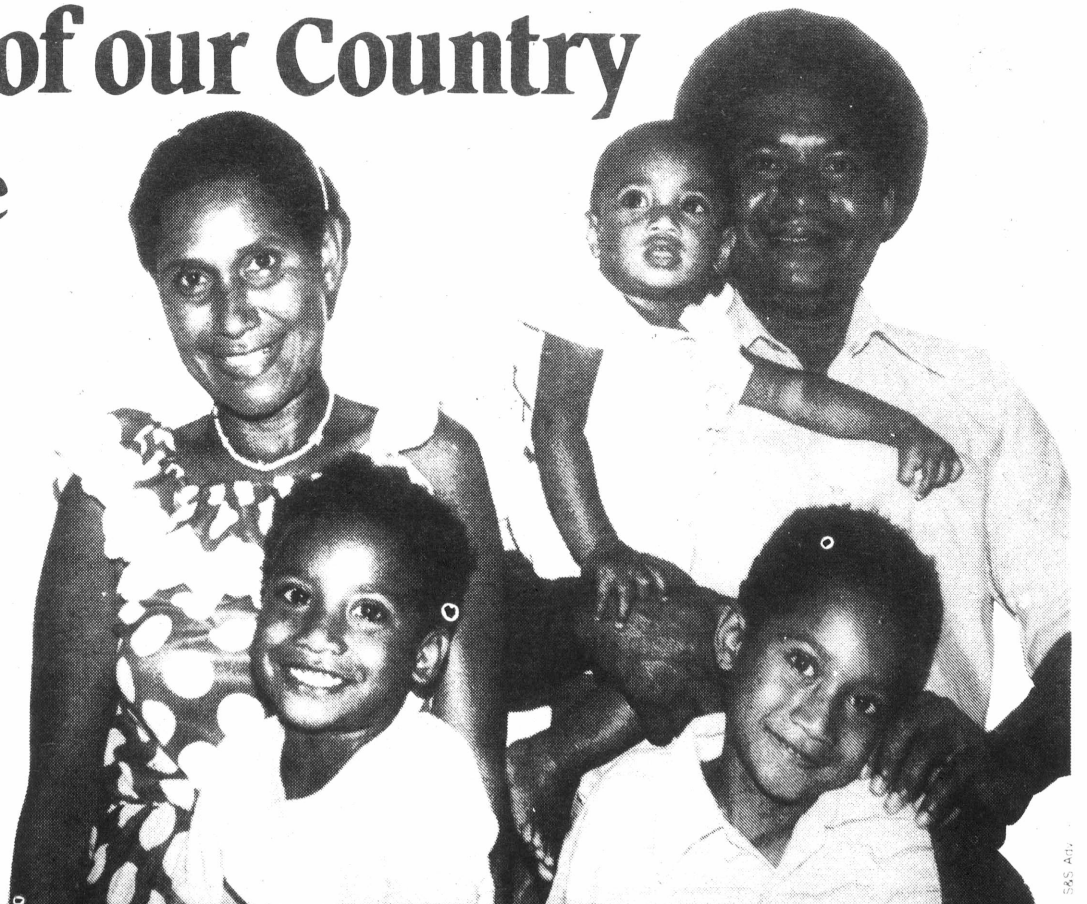

10 Years On... A Healthier Nation.



JOHNSTON'S PHARMACIES



LUKAUTIM BOT em i wanpela saplimen Wantok Niuspepa i ranim long helpim ol manmeri husat i gat pinis ol kain kain bot long kisim save long was gut long bot bilong ol. Ol stori bai tokaut long wanem kain helpim ol liklik bot i ken kamapim, long mekim sindaun bilong ol famili i gutpela sapos ol i stap long ol ailan bilong PNG na save yusim bot long raun bilong ol.

Dispela saplimen bai tokaut long ol pipel tu long wanem kampani long PNG i save salim ol bot bai em i no hat long painim bot yu gat laik long en.

Las wik mipela i ranim saplamen bilong moto. Dispela saplimen i bin tokaut long wanem kain moto i gutpela long wolwara bilong yumi na wanem kain bot i no save kaikai bensin tumas. Mipela bin tokaut tu long wanem kain moto em isi long ranim sapos yu wokim bisnis long painim na salim pinis.

Tupela wik bihain, bai mipela i ranim wanpela saplamen bilong wanem kain samting yu mas gat long bot bilong yu. Lukluk gen long Wantok long kisim moa save long we bilong lukautim bot.

Lek bilong ol long ol pipel ailan

Benny Bogg
i raitim

SOLWARA i rap tru, tasol liklik bot bilong Francis Salin i wok long paat wantaim bikipela si. Mipela ol pasindia long bot i no waswas. Long wanem, dispela bot em ol save-man bilong wokim bot wokim gut na tu wanpela save-man bilong woksip i holim stia bilong em. Mi toktok long wanpela ron long mipela namel long Kairiru Ailan long Is Sepik na Wewak, biktaun bilong ol.

Long dispela taim, mi wantaim pren bilong mi, Schola Salin i bin go long ples bilong em, Solal, long Kairiru long lukim lain famili bilong em.

I gat 7-pela man olgeta long dispela

liklik bot, Papa bilong pren bilong mi, Francis, meri bilong em Philomina, na ol pikinini bilong ol Joe, Mathew, Schola, Keryann na mi.

Bot bilong famili bilong Schola em ol i kolim 'Joelin'. Nem tu i narakain na bot yet i save ran narakain stret. Fran bilong em i save go antap tru long taim papa Francis i pinisim olgeta spit bilong 25 hos-pawa moto o ensin long beksait bilong bot.

Mipela i lusim pinis ples Solal na nus bilong bot i makim stret kona bilong poin Sup long Ailan Muschu. Dispela ailan i drip namel long Ailan Kairiru na Wewak yet.

Poin Sup tu i no gutpela ples tumas long bot i ron. Ol rip i

surik i go ausait long daun liklik na si i save bruk kranki tru long pretim ol nupela kru na siman.

Tasol 'Joelin' i no surik long si bruk. Mipela i lusim poin Sup na makim stret Wewak maunten na haus bilong Primia Jonathan Sengi. Long dispela taim mipela stat long tanim bot liklik na katim si.

Mi sindaun long beksait tru klotu long ensin na papa Francis i wok long tok, "Long taim yu ron long bot, liklik o bikipela, na yu lukim si rap olsem, orait, oltaim putim nus bilong bot sait long katim si. Oltaim katim si long sait, bai bot i no inap long kalap tumas na ensin bilong yu mas stap insait long solwara

oltaim." Ples Medebur i stap antap stret long solwara tu. Mi save dring solwara olgeta de taim mi manki yet na mi save waswas long si. Tasol tumbuna bilong mi na papa bilong mi no gat bot.

Mipela i no tingting long baim ol bot long wanem, i no gat wok bilong bot long hap bilong mipela. Medebur i stap long hap bilong Bogia long Madang Provins, na long dispela hap, rot bilong ka i kamap long ples bilong mi sampela taim long yia 1969 o olsem.

Tasol long Kairiru, sapos ol Japan i wokim bikipela bris long ailan i kam kamap long Wewak em bai ol ka i ken ron. No gat nau na bot em lek bilong ol pipel. Wankain tasol long ol manmeri i stap long ailan Muschu na Vokeo.

Dispela bot bilong Salin famili em i wanpela olpela bot liklik. Francis Salin i

Lukautim Bot

bin baim long wanpela pren bilong em long Wewak. Na em i bin ron long dispela bot wantaim famili bilong em inap tupela yia nau. Francis i no nupela

man long ronim bot. Em i bin wok long ol bot bilong gavman long Madang inap samting olsem 18 yia olgeta. Wanpela bot em i bin wok olsem

ensinia long en em gavman bot 'Koro'.

Dispela bot i bruk pinis na sampela hap bilong

I go moa long pes 30

TRANS MELANESIAN AIRWAYS PTY LTD

P.O. BOX 1975 BOROKO
PAPUA NEW GUINEA
TEL: 213039
TELEX 22341
(LOCATION RPYC POM)

SECOND HAND OUTBOARD MOTORS SPECIALS

EVINRUDE

4HP only K220
15 HP only K650
35 HP only K700
40 HP only K600

Plus! Plus! Plus!
Mercury GHP K600

Plus Plus Plus
Evinrude 6 HP for spare parts (as is where is)

Na tu, i gat ful jeneral sevis na sevis bilong fiksim olgeta kain bagarap wantaim olgeta kain spea pats i stap. I gat nupela lain autbot moto bilong

EVINRUDE
i pulap i stap.

8 HP K735 30 HP K1435
14 HP K835 40 HP K1860
25 HP K995

Mipela i gat olgeta kain samting bilong bot yu gat laik long en.

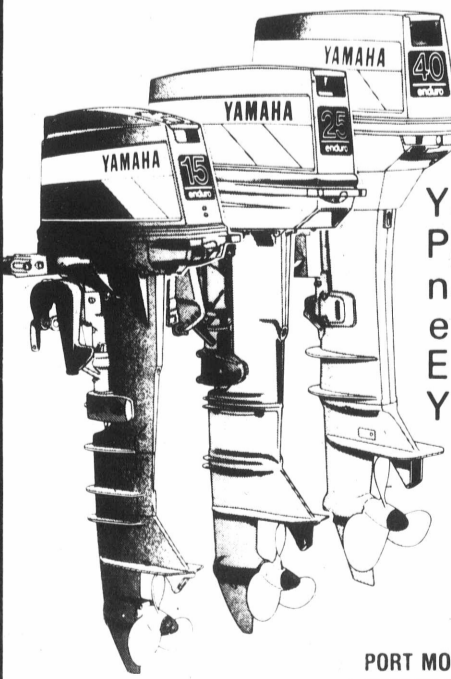

Go wantaim Yamaha

Namba wan long autbot mota

Yamaha i ken givim yu planti kain stail autbot mota insait long PNG. Em i strongpela ensin, yu ken putim bilip bilong yu long em na bai yu no ken tromoi mani nating. Yamaha i gat 2 hos pawa ensin i go inap 175 hos pawa. Tu i gat sevis na spea pats long Ela Motos long olgeta senta insait long PNG. Yu ken bilip long Ela bai ol i ken mekim Yamaha ensin i stap strong yet.



YAMAHA

ELA MOTORS YAMAHA

POWERING THE NATION

PORT MORESBY 21 7036 • LAE 42 2322 • RABAU 92 1988 • MADANG 82 2188 • GOROKA 72 1844 • MT. HAGEN 52 1888 • WEWAK 86 2255 • POPONDETTA 29 7240 • KAVIENG 94 2132 • KIETA 95 6083 • KIMBE 93 5155 • TABUBIL 58 9060

A MEMBER OF THE BURNS PHILP GROUP

en i slip nau aninit long solwara bilong Madang.

Olsem na taim yu sindaun long bot Francis Salin i stiaman long en, yu ken putim ol wari long baksait na opim wanpela bia na apim gut. Maskisi i rap olsem long dispela taim mipela i bin pait wantaim si ya.

Dispela ron bilong mipela i las raun bilong mi long dispela bot. Mipela i kamap long Wewak bihain long 45 minit tasol na mi tok gutbai long 'Tolin' na Francis Salin.

Mipela i bin lusim Wewak gen long na-



rapela de wantaim mama Philomina na liklik Kerryann na kamap long Madang long narapela de. Sip bilong Lutheran Shipping oi i kolim Manemba i kisim mipeia.

Tru. Long taim yu stap long ailan na yu gat bot, yu bai amamas. Dispela bot em olsem ka bilong yu. Long graun, yu ken woka-baut i go long ples yu laik go long en. Tasol long ailan, dispela bot i

olsem lek bilong yu. Em stret. Lek bilong yu na famili bilong yu.

Sampela taim, Francis Salin wantaim pikinini bilong em Jochim Salin husat i stap wantaim em long ples, i save yusim bot long painim pis. Na taim oi i kisim planti pis tumas, bai yu ken lukim oi long Wewak, aninit long ol yar diwai we ol ailan manmeri i save putim ol bot bilong ol.

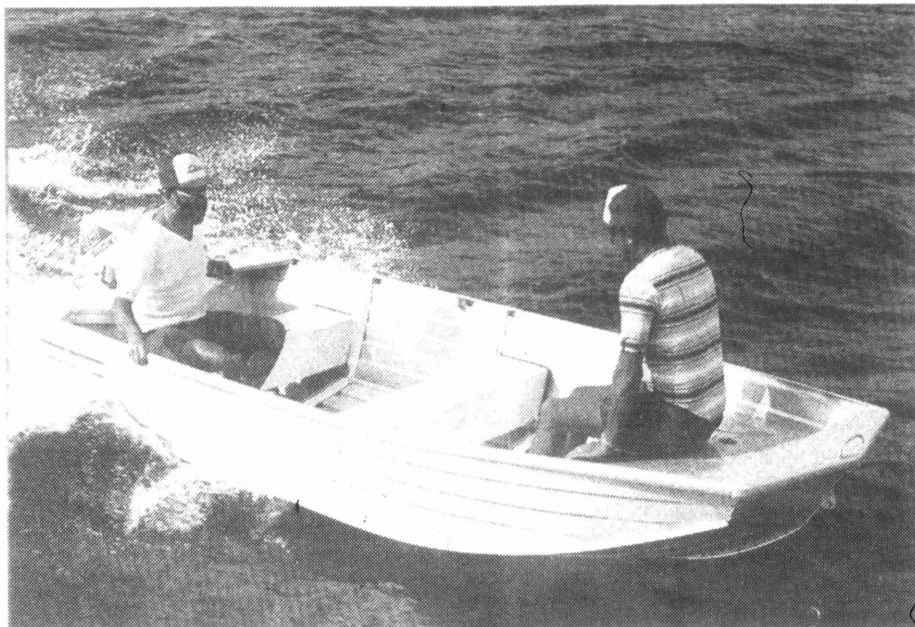

Sevim bensin long moto

LONG PAPUA NIUGINI olsem long ol arapela hap long wol, sapos ol pipel i yusim bensin long ol autbot mota ol i lusim bikpela mani tru long baim bensin oltaim. Dispela liklik stori i kam long Dan Wilcox bilong Pioneer Bible Translators. Em i tok em yet i save traim dispela liklik rot na em i save wok oltaim.

Pe bilong ol fuel teng bilong ol autbot moto em i bikpela tumas. Na long taim ol kanu o bot i ran long longpela hap tru ol i save yusim wanpela tang na sampela 20 o 25 lita dram. Dispela em i no gutpela tumas.

Wanpela rot bilong daunim dispela pasin bilong karim planti dram tumas long ol kanu o moto bot em long yusim wanpela 60 lita dram long kamapim spea tang bilong bensin.

Hia em pasin bilong mekim dispela spea tang:

a) Drilim hul long ai bilong wanpela spea fuel dram. Dispela hul i mas bikpela inap long wanpela kopa paip i go insait long en na dispela paip i mas fit tait tru long fuel lain. Yu ken wokim wanpela liklik hul tu long dram we win i ken go insait.

b) Katim paip em longpela bilong em inap long 5 sentimita. Na yu katim tu wan kain sais bilong fuel lain.

c) Kisim wanpela fuel konekta em i go long moto. Dispela i ken nupela o olpela tu em i orait tasol. Pat namba bilong Yamaha na OMC Johnson/Evinrude em Yamaha 655-24304-02 na OMC em 376154.

Putim dispela fuel konekta long sotpela hap bilong fuel lain na putim hap kopa em inap long sentimita samting long narapela hap. Yusim ol skru klemp long krungutim i go daun. Orait putim dispela samting antap long ai bilong fuel dram we dispela hap kopa i hangamap i kam ausait long hul.

d) Orait nau yu ken katim narapela hap fuel lain gen. Dispela hap lain em i mas longpela i go daun we em i ken sindaun long as bilong wanem dram yu laik yusim. Orait putim i go long hap kopa em i stap aninit long ai bilong dram na krungutim i go daun wantaim wanpela skru klemp.

e) Katim narapela hap gumi gen. Longpela bilong gumi ya i mas namel long 15 i go inap long 25 sentimita samting. Orait krungutim dispela gumi i go inap long 90 digri na tanim longpela hap bilong em. Orait wokim samting olsem 10 o 20 liklik hul long dispela longpela hap na dispela hap bai i wok olsem fuel strena. Orait autim dispela hap long fuel lain na krungutim i go daun long kiemp.

Mi yet i save putim wanpela fuel filta long dispela fuel lain long helpim mota bilong mi.

Em i no dia tumas na bai map long helpim yu na mota bilong yu.

Dispela stori i kam long YUMI KIRAPIM NO. 30

First again in '85

EVINRUDE

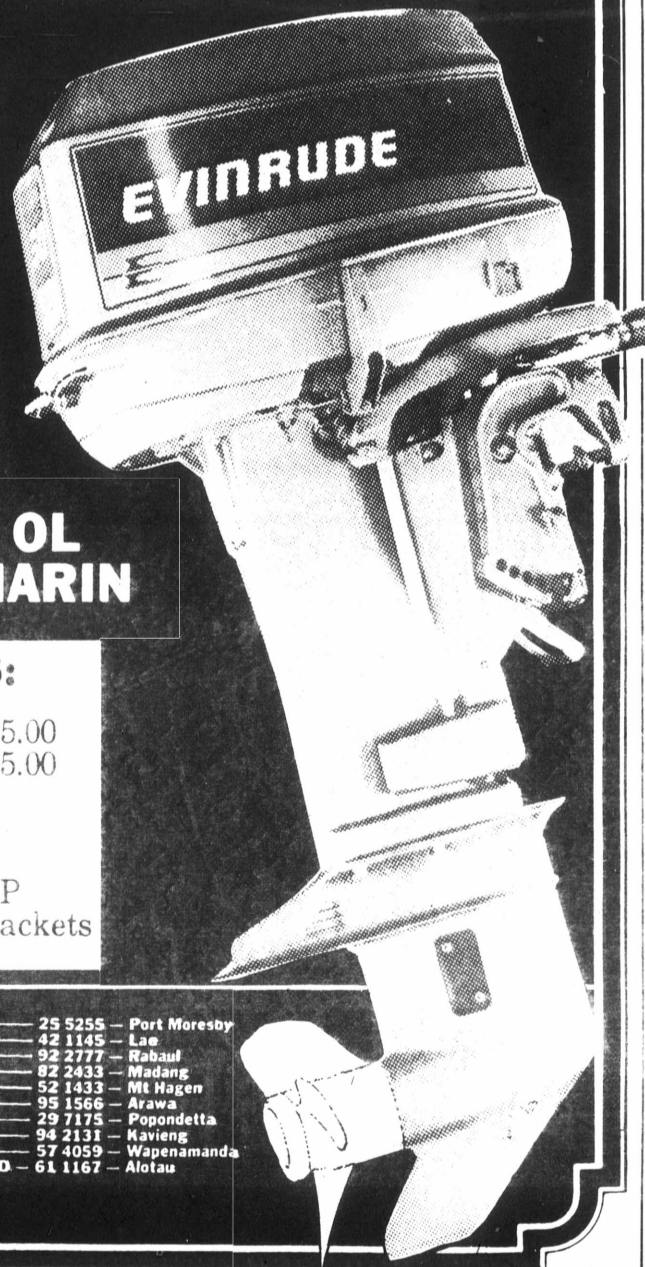
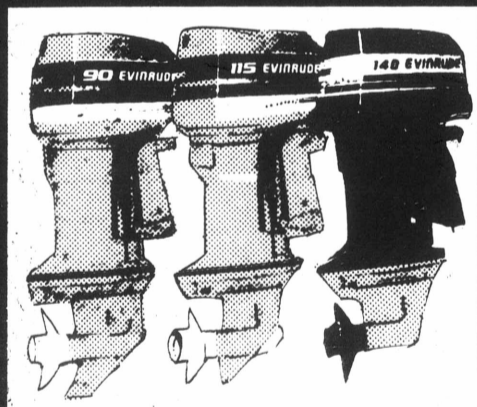

MIPELA INVENTIM OL AUTOBOD MOTOR MARIN

AUTOBOD SPESELS:

14 HP Evinrude longshaft K735.00
25 HP Evinrude longshaft K895.00

MORESBY TASOL

120 Dinghy complete with 14HP Evinrude — fuel tank & 2 life jackets K1750.



BOROKO MOTORS	25 5255	Port Moresby
BOROKO MOTORS	42 1145	Lae
BOROKO MOTORS	92 2777	Rabaul
BOROKO MOTORS	82 2433	Madang
BOROKO MOTORS	52 1433	Mt Hagen
ARAWA MOTORS PTY LTD	95 1566	Arawa
HIGATURU MOTORS PTY LTD	29 7175	Pogondetta
PROVINCIAL AGENCIES PTY LTD	94 2131	Kavieng
TORO MOTORS PTY LTD	57 4059	Wapenamanda
MILNE BAY ENTERPRISES PTY LTD	61 1167	Alotau

Lukautim Bot

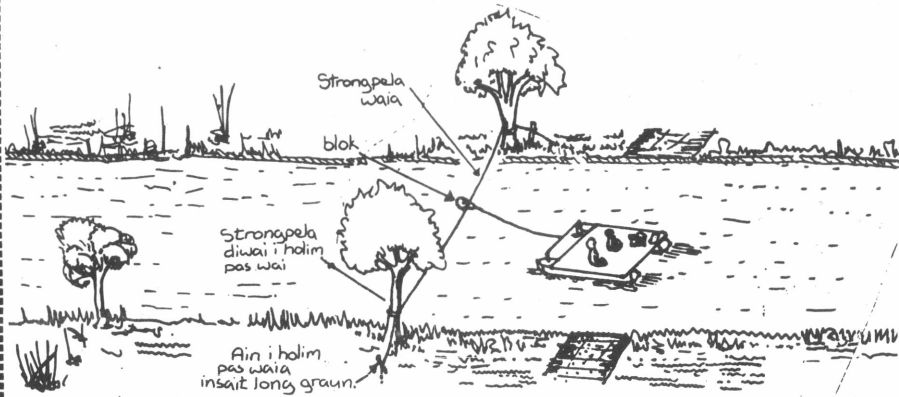

● 1. Wara i subim bot na ol man i sindaun nating.

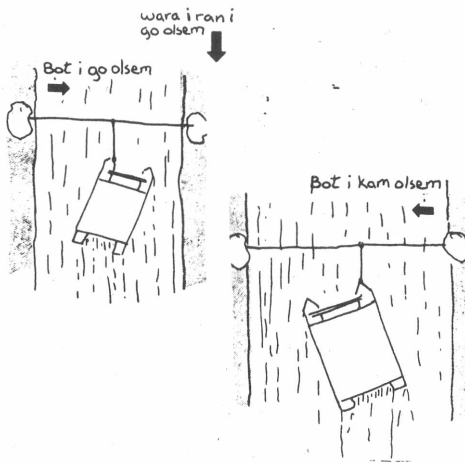

● 2. Ples bilong rop i pas long en, dispela i mekim na bot i go o bot i kam.

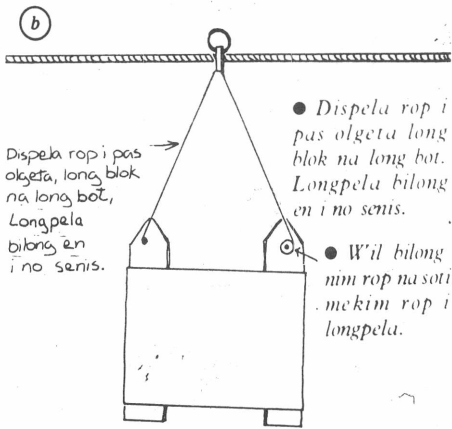
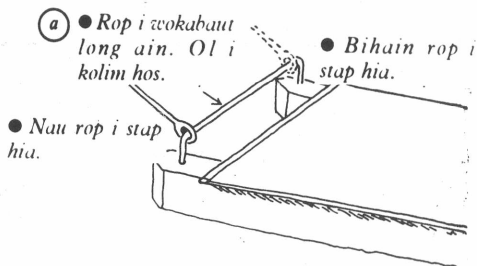

● 3. Pasim bilong senisim rop. Long Berina, Sentral Proviens ol i pasim wanpela rop tasol (Lukim piksa a). Tasol long Is Nu Briten ol i save pasim tupela rop (lukim piksa b).

Wara yet i subim bot

LONG TAIM bilong ren, tait i save brukim planti bris long ol ples insait long Papua Niugini. Tasol planti bikpela wara insait long PNG i no gat ol bris we ol pipel i ken kalapim wara. Sapos ol i laik kalapim wara i go long narapela sait, orait man o meri i mas pul long kanu i go.

I gat wanpela rot we ol pipel i ken brukim wara i go long narapela sait. Tasol ol i no inap long hatwok long pul, o swim nogat. Ol i ken sindaun isi tasol na larim wara yet i karim

ol i go long hapsait. Orait bihain wara yet i ken karim ol i kam bek gen.

Tok bilong rop i pulim

Long nus bilong dispela kain bot i gat ain i stap long holim pas rop. (Lukim piksa 1). Bilong brukim wara i

go, rop i mas pas long hapsait i kam. Bilong brukim kam, rop i pas long hap i go (Lukim piksa 2).

Tok bilong pasim rop

I gat tupela rot bilong senisim rop i go i kam. (Lukim piksa 3).

Marine And Ships CHANDLERY

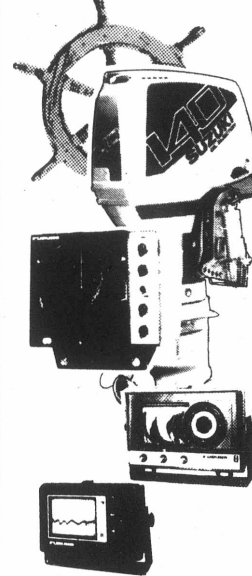

- Ford — Industrial & Marine Engines, Lees Marine Engines.
- Suzuki — Outboards, Generators & Pumping Sets.
- Furuno — Radar, Echo Sounders, Sonars, Radios.
- Brooks & Gatehouse, V.D.O., Seafarer, Saura, Shipmate — Instruments.
- Ronstan, Fico, Simpson, Vetus — Blocks, Hydraulic Steering, Swages, Rigging, Rope, Hatches, Vents, Stainless Steel Bolts - Nuts - Washers.
- Parker N2 — Aluminium Extrusions
- Markon — Alternators.

LOHBERGER ENGINEERING

21-2034
21-1614

LAWES ROAD BOX 810 PORT MORESBY

Aluminium Boats and Dinghy's

From K670 aprox.

- X Ol i smat moa — bai stap strong oltaim
- X Ol i gutpela bilong yusim na painim pis.
- X Longpela bilong ol, em i 3 mita i go inap 6 mita.
- X Mipela i gat ol SUZUKI autbot mota i pulap i stap

- * Telefax-morse controls and steering
- * Marine equipment inc

V.D.O. instruments
Ritchie compasses
Batteries
Marine Transceivers
Depth Sounders

Sapos yu laik baim, askim mipela pastaim.

HUON MARINE

LAE
421125
BOX 785
TELEX 44191

RABAU
922574
BOX 248
TELEX 92976



DESIGNED FOR
PAPUA NEW GUINEA
WATERS

Workboats..
Fishing boats... Speed boats.

Span Enterprises
PTY. LTD.

SALAMO — LAE — RABAU — PORT MORESBY

WRITE FOR BROCHURE BOX 1401 POM

LONG TAIM planti pipel long ol nambis long PNG i wok long yusim yet ol kanu long painim pis, i gat wanpela man i wok long baim ol dingi long ol kampani nau long taun long mekim wok bilong painim pis.

I gat kain kain ol dingi ol kampani i save salim ol dingi hia long Papua Niugini. Na ol lain bilong gavman olsem Plis Fos. DPI, ol provinsal gavman na ol arapela lain i save yusim tu ol dingi long mekim wok

bilong ol.

Wanpela kain ol dingi em Stimsip kampani i wok long salim nau em ol i kolim Stessl. Dispela liklik dingi em inap long mekim kain kain wok. Yu ken kisim famili bilong yu raun long en, o go painim pis long solwara na long ol riva tu. Em i strongpela liklik dingi.

I gat 28 kain stail bilong dispela ol Stessl dingi. Tasol Stessl i no save

wokim ol dingi tasol. Ol i save wokim ol bot tu em ol pipel o kampani i ken baim. Ol lain bilong Australia Nevi tu i save yusim ol dispela dingi bilong Stessl long wanem kain

kapa em ol i yusim long wokim dingi i strong tru.

Ol liklik bot em ol i wokim long ol kain klas samting i gutpela long yusim. Na planti ol pipel i wok long baim ol dispela

kain bot tasol bot ya i hevi liklik long tanim hariap. Olsem na ol lain husat i les long ol kain bot olsem i wok long painim nau ol kain liklik bot o dingi em ol i wokim long aluminium.

Alf Stessl em i man husat i bin statim dispela famili bisnis bilong em long wokim ol dingi na liklik bot nabaut long Australia. Na nau em i amamas long dispela famili bisnis

bilong em i wok long ran gut nau. Tasol em i tok olsem ol lain bilong em i wok long kamapim ol nupela aidia na traim yet long painim ol kain liklik bot o dingi em ol manmeri i laikim. Na tu we ol i no inap long tromoi bikpela mani tumas long baim na lukautim.

Painim gutpela dingi o bot





MARINER

OUTBOARDS

10th year
Independence
Anniversary
Special!



**30hp
long shaft
K1075**



**40hp
long shaft
K1289**

Meridien Motors
PORT MORESBY 252477 LAE 422869

**Sales ends 30th of
Sept 1985**

WOK O PILAI, BIHAINIM STESSL WEI TASOL

Quintrex
ENGINEERED ALUMINIUM BOATS

INTERNATIONAL
Stessl

Yellowfin
Custom Built Boats

STESSL IGAT KAIN KAIN BOT LONG PNG

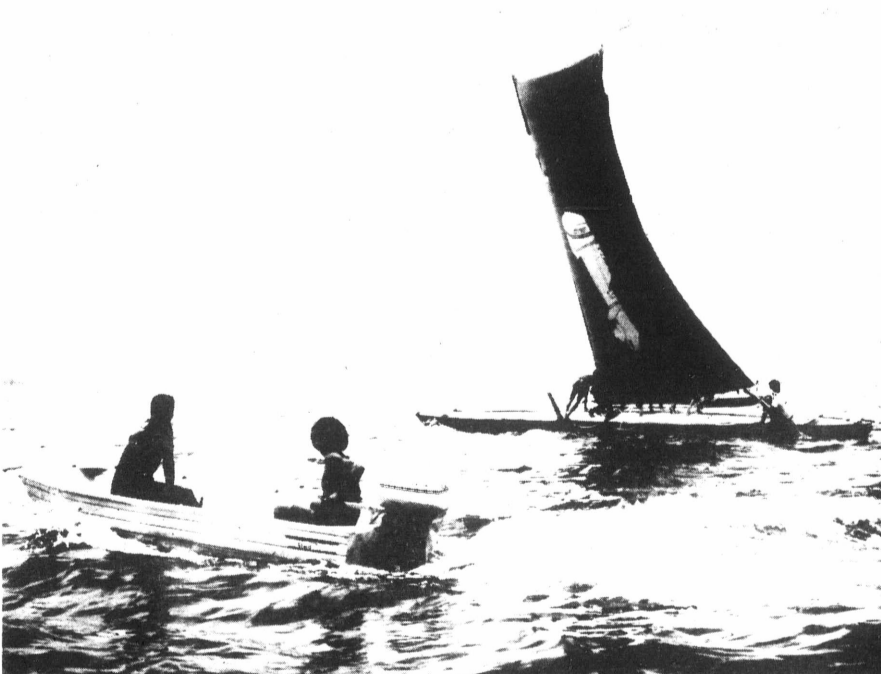

OL I SALIM
NA SEVISIM
LONG

Steamships - MACHINERY

PORT MORESBY 259066	LAE 43 1253	MADANG 82 3021	RABAUL 90 1290	KIETA 95 6246
------------------------	----------------	-------------------	-------------------	------------------

HEB 2887

Senisim tingting wok bungwantaim

LONG MAKIM namba 10 yia bilong independens long Papua Niugini, planti misinari na bisop, pater, bruder na sista long kantri bai givim toktok na singautim pablik long tainim bel, lukluk bek long laip bilong ol 10-pela yia i go pinis na statim gen nupela laip bilong bihainim wok Jisas Krai i statim long graun — mekim wok bilong gutpela kristen.

Wankain olsem John bilong Baptais, Asbisop bilong Mosbi, Peter Kurongku i singaut long stretim ol ples i gat hul long laip bilong ol nesanel memba bilong yumi na tu ol pablik sevan.

"Mi olsem lida bilong sios bilong mi, wanpela wok bilong mi em long tok save long ol pipel long wanem kain samting i gutpela long laip na wanem kain samting bai bringim amamas long sotpela taim, na i no gutpela long laip bilong ol. I mas tok lukaut long ol long wanem kain samting ol i mekim i no stret long lo bilong sios." Peter Kurongku i tok long wanpela toktok bilong em long makim namba 10 yia em PNG i kisim independens.

Em i singaut long ol lida bilong kantri na ol pablik sevan long lusim pasin bilong tingting long ol yet, na stat long tingting long ol arapela manmeri tu.

Asbisop Kurongku i tokim ol lida bilong kantri, "Yumi mas statim nupela laip nau. Hamas taim yumi opim nuspepa na harim long redio na planti taim yumi i abrus long mekim gut wok bilong ol na kalapim lo bilong kantri? Yumi harim ol lida bilong yumi i gat sas bilong stilim mani, givim grismani long kisim sapot, givim wok long wantok bilong ol yet, na planti kain pasin olsem?"

Em i tok olsem, kain pasin olsem long level bilong ol bikman long kantri i mekim ol "raskol" i pilim olsem ol i lusim sans bilong ol tu long kisim mani. Olsem na ol i kamapim kain pasin bilong stil Ol i no gat hop long gavman bilong ol i helpim ol i painim gutpela sindaun long kantri.

Asbisop Kurongku i tok olsem, yumi tingting long helpim ol arapela husat i stap klostu long yumi bai sindaun bilong yumi kamap gut. Yumi no ken lukluk long provins. Maski em i bilong Papua o bilong Niugini o bilong Hailans na ol ailan. Yumi mas wok olsem pipel bilong wanpela kantri.

"Long ol lida bilong mipela, politisen, pablik sevan na ol komyuniti lida; God i putim bikpela wok lukautim ol pipel bilong em long han bilong yupela. Em i givim yupela moa pawa long ranim gut dispela kantri. Olsem na yupela ol lida i gat bikpela wok bilong karim hevi bilong ol pipel. Dispela wok, yupela i mas mekim gut long nem bilong God na pipel bilong em." Asbisop Kurongku i tok.

Em i tok, long mekim gut wok i no isi samting. Planti taim kain kain traim i kamap. Bai i gat planti sans we ol politisen i ken kisim mani long trik bilong ol. I gat planti sans we ol politisen na lida i ken putim ol yet i go pas long wok na pipel ol i makim long kantri. Tasol trupela lida i mas sakim beksait ol dispela traim na bihainim wok bilong Jisas Krai long helpim ol manmeri.

Em i tokim ol man bilong mekim lo na ol etministreta; yupela tu i mas bihainim lo bilong God. Olgeta lo bilong kantri mas bihainim lo em God i givim long ol pipel.

Sande lotu

Frank Mihalic

SANDE NAMBA 26 BILONG SIOS

YIA

(1 Oktoba 1985)

Long stori bilong tude (Mak 9:38-43) ol aposel i jeles long wanpela man i kolim nem bilong Jisas na i wokim sampela mirakel. Ol i no laik.

Tasol Jisas i tokim ol, "Yupela i no ken kros. Larim dispela man. Sapos em i singautim nem bilong mi, em no ken egens long mi. Man i no wok egens long yu, em i helpim wok bilong yu yet."

Tude yumi gat planti lain kristen na olgeta ol i pait wantaim ol narapela. Long PNG i gat moa long 34 lain kristen. Wan wan i tok em i mekim wok bilong God; wan wan i tok em i lain i tru na ol arapela i rong. I gat wanpela stori nating long dispela samting. Stori i go olsem.

Jisas i tokim mipela, em i no bin lukim wanpela pilai soka yet. Olsem na ol pren na mi i kisim em i go long wanpela bikpela pilai. Tupela strongpela tim tru i pilai. Nem bilong wanpela tim Katolik Kauboi; na nem bilong arapela tim Luteran Lakiman.

Orait, gem i stat na ol Kauboi i givim namba wan gol. Jisas i amamas na i singaut strong. Tasol kwiktaim na ol Lakiman tu i givim gol. Wantaim moa Jisas i kalap na sanap antap long sia na i singaut na amamas.

Wanpela man i sanap klostu em i lukim na i longlong nau. Em i sutim pinga long solda bilong Jisas na i askim, "E, yangpela yu smabai long wanem tim?"

"Mi, a?" Jisas i bekim tok. "O mi no sambai long wanpela taim. Mi amamas long gutpela pilai tasol." Na em i lap na i paitim han gen.

Man ya i harim dispela tok, na em i tanim long poroman bilong em na i tok, "Wanpela blari haidenman tasol i ken tok olsem, long taim ol Luteran na ol Katolik i resis long pilai."

Taim mipela i wokabaut wantaim Jisas na i go bek long ples, mipela i skulim em long pasin bilong ol sios tude ... olsem wanem na ol i resis na pait nabaut namel long ol.

Na mipela i tokim em olsem, "Bikman, tude olgeta wan wan sios i save ting God i stap long sait bilong ol, na em i egens long ol arapela sios."

"Yes, mi save pinis," Jisas i tok. "Na bilong dispela mi no tingting tumas long ol kain kain sios. Mi tingting long ol pipel. Sios i no mekim pipel. Pipel i mekim sios."

Mipela i harim dispela tok na mipela i givim tok lukaut long Jisas. Mipela i tokim em olsem, "Lukaut, Jisas. Kain tok olsem i bin kilim yu indai bipo..."

"Yes, em i tru," Jisas i tok. "Na husat i bin kilim mi i dai? Ol man i strong long sios bilong ol tasol." Na em i smail.

Sapos yumi resis long toktok long wanem sios i namba wan tru, na wanem sios i tru olgeta - bai no gat samting i kamap. Toktok tasol. Kros tasol. Long wanem, i no gat wanpela man o meri i bilip tru, ol arapela sios ol i inap long soim bilong em. Sapos em i bilip olsem, bilong wanem na em i stap long dispela sios bilong em, na i no long arapela sios?

Wan wan sios i olsem wan wan rot i go long God. I gat kain kain rot, i gat kain kain sios. Sapos yu laik save wanem rot i win, yu mas save wanem rot i bin bringim moa manmeri i kamap long God. Na hia long graun husat bilong yumi i ken save long dispela samting?

Sios i mekim ol pipel insait long em i holi na i santu na i gutpela manmeri, dispela sios i win. Em i wok bilong olgeta sios. God wanpela tasol i ken save husat i win long dispela wok. Long wanem, i gat planti planti sios tu i no kristen olgeta. Na yu ting wanem, ol memba bilong ol i lus? Ol i no inap kamap long God, laka?

Olsem Jisas i tok long gutnius bilong tude gen, "Sapos ol i wok wantaim yumi em i min, sapos ol i mekim ol man i holim na i bringim ol long God ... ol i no egens long yumi." Ating yumi jeles tasol, olsem ol aposel long stori.

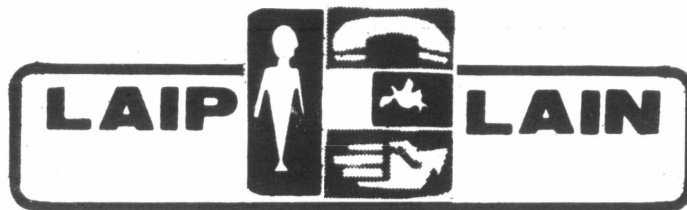

No gut gelpren gat bel

DIA LAIPLAIN,

Long taim mi bin go long ples long skul holidi bilong mi, mi wantaim gelpren bilong mi i bin slip wantaim. Olsem na nau mipela i wari olsem nogut em i gat bel.

Bai mipela i mekim wanem tru nau?

SKUL MANKI.

Dia Pren, Ating yu wantaim gelpren bilong yu i no bin tingting long wanem kain wari bai kamap long taim yutupela i bin slip wantaim long dispela taim yu bin go holidi.

Yu traim tingting. Olsem wanem sapos gelpren bilong yu i karim pikinini na no gat wanpela bilong yupela i laikim dispela bebi? Yu wantaim gelpren bilong yu i yangpela tumas long lukautim dispela pikinini nau na tu yupela i yangpela yet long tingting long marit.

Namba wan samting

em gelpren bilong yu bai painimaut sapos em i gat bel em olsem, em bai abrusim sik mun bilong em. Susu bilong em bai skrap na em bai pilim susu i hevi. Em bai inap painimaut tu olsem em bai pilim pispis klostu, klostu.

Samting olsem 5-pela mun bihain long em i gat bel, bai bel bilong em i go bikpela liklik.

Sapos gelpren bilong yu i ting olsem em i gat bel, orait, em i mas go lukim dokta o klinik long medikal sekap.

Ripot bilong planti dokta i tokaut olsem, ol manmeri husat i slip wantaim long amamasim bodi bilong ol tasol long sotpela taim, i no

save gat bikpela laik long poro bilong ol.

Ol dispela kain manmeri i ken kisim kwik ol sik nogut em ol manmeri i save kisim long taim ol i slip wantaim man o meri husat i gat dispela sik.

Tingting long olgeta dispela samting em mipela i autim nau, wantaim gelpren bilong yu.

Yu tupela tu i mas traim long save long planti arapela yangpela manmeri, bai bihain yutupela inap long makim gut husat pren em yupela i laik maritim na stap wantaim oltaim.

LAIPLAIN.

Ol wokmanmeri o kaunsil bilong Laipain i sambai tasol long helpim ol manmeri i gat wari. Yu ken ringim ol long telipon namba 257711 namel long 10 klok long moning na hap pas wan long apinun. Yu ken ringim ol tu namel long 4 klok apinun na 9 klok nait, em long olgeta Mande i go inap long Fraide.

Yu ken putim wari bilong yu long leta na salim i go long Laipain, P.O. Box 6047, Boroko. NCD.

Wantok BUK KLAP

LUKIM WANEM BUK YU LAIKIM NA SALIM TASOL MANI I KAM NA BAI MIPELA I SALIM BUK BILONG YU I KAM.

- Putim dispela mak x insait long boks long makim wanem buk yu laikim.
- Prais bilong buk i karamapim pe bilong pos opis insait long PNG.
- Bai i gat ol nupela buk bilong Wantok Buk Klap olgeta tupela wik.

Pocket Dictionary
by John Grisewood
Wantok book club prais K3.95

Beginners guide to Woodwork
by Tony Lawley
Wantok book club prais - K2.95

Tom Thumb
by Mae Broadley
Wantok book club prais K1.60

Story Of Music
by Simon Mundy
Wantok book club prais K7.75

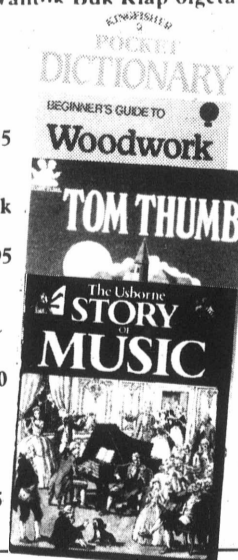

Salim dispela fom wantaim sek o posta oda bilong yu i kam long: Wantok Buk Klap, P.O. Box 1385, Port Moresby.

NEM: _____

ADRES: _____

- Salim oda bilong yu i kam.
- Ol buk bai kamap bihain long 28 de.
- Olgeta buk ya i kam long WEB Books.
- Putim oda bilong yu long dispela fom tasol.

DOUBLE UP Na Kamap LAKI

Wei long pilaim
dispela niupela
pilai!



Sigirapim
dispela hap
tasol.

Na sapos tripela
wankain namba i
kamap em
dispela bai yu
winim.

Tasol, sapos yu
sigirapim na
painim "Double
Up" na tripela
wan kain namba,
em bai yu kisim
prais tupela taim.

Olsem, sapos yu sigirapim tiket na painim tripela K5.00, orait em bai yu kisim K5.00 tasol. Tasol sapos Double Up tu i kamap em bai yu plasim narapela K5.00 na bai yu kisim K10.00.

Long dispela wai tasol bai yu ken winim K10,000. Sapos yu sigirapim tripela K5,000 na painim 'Double Up', yu save pinis yu bai kisim K10,000.

Sapos pik i kamap, raitim nem long baksait long tiket na givim igo bek na kisim fri tiket.

Insait long dispela tiket, igat planti moa prais long winim olsem.

K1.00, K2.00, K5.00, K10.00, K50.00, K100.00 K500.00, K5,000.00, K10,000.00 na bikpela prais — K25,000.00.

Dispela bikpela prais K25,000.00 bai wanpela laki man o meri i winim taim ol bungim olgeta tiket i gat pig na wanpela man i pulim Laki Pik tiket.

K2
K5
K10
K50
K100
K500
K1,000
K5,000
K10,000
K25,000

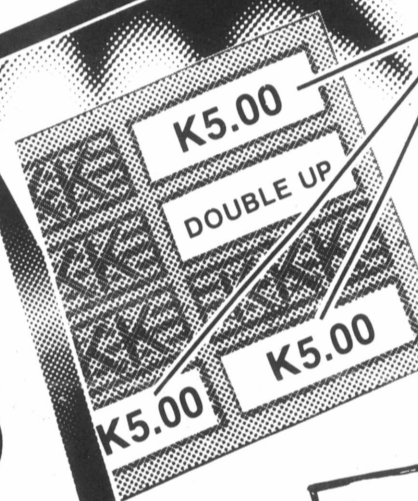

Agum na Amom salensim Aronta



LONG TAIM bilong tumbuna bipo tru i gat tupela brata i stap long Legam Viles klostu long Wara Mankon insait long Buangeria long Morobe Provsins. Namba wan brata, em Agum na namba tu brata, em Amom.

Agum na Amom i stap long hap sait bilong wara. Na masalai meri, nem bilong em, Aronta i stap long narapela sait. Dispela lapun meri, Aronta i gat bikpela gaden i pulap long taro, banana, yam, kaukau, pitpit, sugaken na planti arapela kain kaikai. Na ol dispela kaikai i save sting nating.

Agum na Amom i no bin save olsem Aronta i stap long hap sait bilong wara. Long wanpela taim tupela i lusim Legam na wokabaut i go daun. Na Agum i lukim smok bilong paia i kamap long hap sait bilong wara.

Orait, tupela i wokabaut i go klostu long ples bilong Aronta. Ples i klia tru na ol i lukim Aronta i sanap i stap. Tupela i pret long Ronta tasol ol i wokabaut i go klostu.

Ol i lukim Aronta klia tru. Aronta i no luk olsem masalai meri. Nogat. Em i olsem meri tru. Tasol ol kapa long olgeta pinga

long hanlek bilong em i longpela tru. Na em i gat planti longpela gras long het na bodi bilong em.

Tupela brata i sanap lukluk i go na ol i pret, nogut Ronta i kilimol. Na ol i wokabaut i go long ples bilong ol.

Ol i go stap long ples inap long sampela yia. Amom i kamap bikpela man na maugras bilong em i kamap. Na tupela i pasim tok long go bek na kilim Ronta.

Ol i giaman long wokim wanpela bris i brukim wara igolonghap bilong Aronta. Long tripela de olgeta, ol redi long olgeta samting bilong pait. Ol i kisim limbun na wokim spia long en. Bihain long tripela de i pinis, ol wokabaut long giaman bris na kamap klostu long haus bilong Aronta.

Agum wantaim Amom i wokabaut isi i go na sanap aninit long haus. I no longpela taim, Agum i lukim longpela gras i hangamap long haus na hap bilong en i go daun tru long graun. Dispela gras i kamap long sangana bilong Aronta.

Dispela tupela brata i brukim wanpela stik. Ol i holimpasim gras na tanim tanim long stik. Ol gras i raunim stik strong tru. Ol i pulim stik na kamautim sampela gras bilong Aronta. Man, Aronta i pilim pen na em i kirap

nogut. Na em i kalap i go antap na go daun long wanem planti gras long sangana bilong em i bruk na lus nabaut na em i pilim pen nogut tru.

Aronta i singaut, "Husat man i skrapim mi long pait nau?"

Agum i go sanap long ples klia na i tok, "Aronta, nau bai yu dai. Mitupela brata bilong mi i kam long pait wantaim yu."

Aronta i tokim tupela long wet na bai em i go kisim ol samting bilong em long pait. Em i go insait long haus. Em i kisim tupela longpela tit bilong em na putim i go long maus bilong em. Na em i kisim tupela hap limbun bilong sakim spia long en.

Em i kam ausait long haus na opim maus bilong em. Tupela tit bilong em i brukim olgeta samting rabaut. Em i kalap i go daun long graun na ranim Agum wantaim Amom.

Agum i tromoi wanpela spia i go long pes bilong Aronta. Tasol spia i popaia na pundaun long ples nating. Long dispela taim stret, klaut i pairap na draipela ren i pundaun. Bikpela win i kirap na haiwara i karamapim dispela ples ol i sanap long en.

Haiwara i krungutim olgeta hap bilong Legam i go daun long hap bilong Bumatu eria na long Maus Buang. Aronta i no

wari long ples i bagarap. Em i ronim Agum na Amom i go kamap arere tru long Wara Mankon.

Agum i ron na giaman Ronta long bihain. Amom i go pas na sanap long hap sait bilong bris. Agum i giaman Ronta i go kamap namel stret bilong bris. Na em i ron i go kamap kwiktaim long hapsait na sanap wantaim Amom.

Aronta i ron i go yet na Amom i katim rop bilong bris. Bris i bruk wantaim Aronta i go daun long Wara Mankon na wara i karim em i go daun. Na Aronta i bamim maus bilong em antap long draipela ston. Na wanpela tit bilong em i bruk. Em i trai hat long swim na brukim haiwara i go long gutpela ples. Tasol nogat. Tarangu i no gat strong moa.

Agum wantaim Amom i wokabaut long sait bilong wara na bihain Aronta i go daun. Ol i go kamap long ples we Wara Mase na Wara Yes i bung long en. Tasol Aronta i putim lek bilong em long gutpela ples na sanap gen long graun.

Aronta i kirap gen na ronim tupela brata gen. Ol i kirapim pait gen na bihain sait bilong wara i go antap. Spia bilong agum i go pinis olgeta. Long wanem em i wok long tromoi planti spia na popaia.



JOSS TOMARINAKIP

Agum i givim spia bilong em i go long Agum. Tasol Agum i wok long popaia na tromoi spia i go nating. I gat wanpela las spia tasol bilong Amom i stap yet.

Agum i taitim bun na swingim dispela las spia i go insait stret long bro bilong Aronta. Man, Aronta i singaut strong na swingim hanlek i go go nabaut na trai hat long raunim spia. Tasol nogat. Spia i sutim lewa bilong em na em i hap indai na pundaun i go daun long graun.

Agum i kamautim spia gen na sutim i go long het bilong Aronta. Long wanem Aronta i no dai yet. Aronta i traunim long sanap gen. Tasol nogat. Em i kirap na pundaun i go daun na indai olgeta.

Orait, Agum na Amom i lusim Aronta long hap ples em i slip long en, na tupela i go wokabaut arere long wara i go antap. Tasol hanlek bilong tupela i slek tu na ol i sotwin.

Ol i wokabaut i go liklik taim bihain na sindaun. Tasol tupela i tanim na

kamap tupela maunten na stap olgeta long dispela eria. Dispela tupela maunten i stap klostu long Legam na Bumatu.

Sapos ol manmeri i go long dispela eria tude, bai ol i lukim dispela tupela maunten i sanap i stap. Ol pipel bilong dispela eria i kolim dispela tupela maunten - Agum na Amom. Em i bihainim nem bilong tupela brata ya.

Arim Nipaya, Magem Viles, Buang, Morobe Provsins.

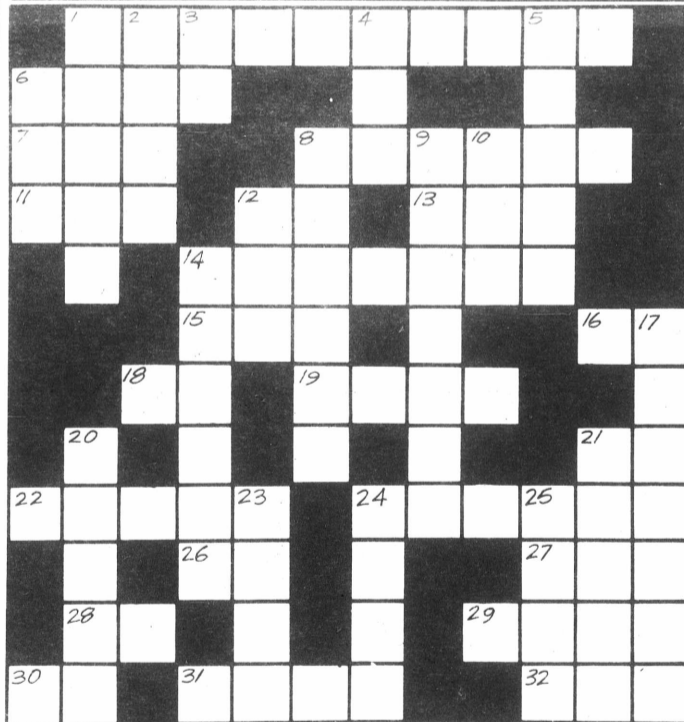
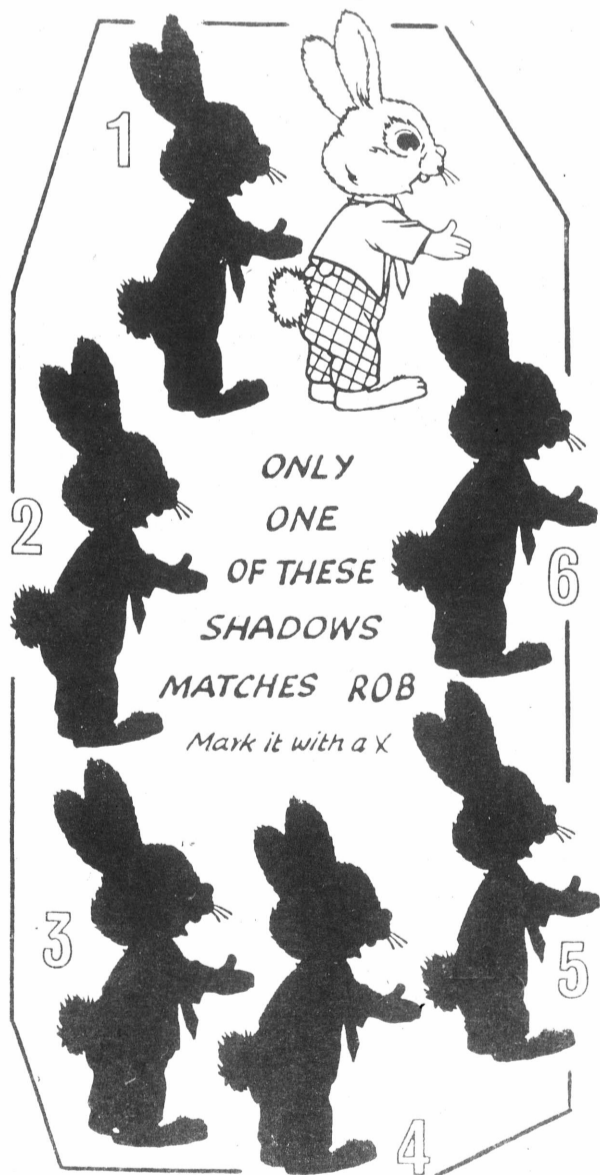

Ansa bilong las wik:

Antap i go daun

- 2. PNGB. 13. Boskru
- 3. Tu 15. Tit
- 4. On 16. Musik
- 5. Oro 18. Mi
- 6. Pasmidia 21. Tu
- 7. Biala 22. As
- 8. Ararua

Lep i go long rait

- 1. O.P.M. 14. Ren
- 3. To 15. Tambu
- 5. Op 17. Ami
- 7. Banara 19. Ok
- 9. Ragbi 20. Ia
- 10. Ros 21. Tisa
- 11. Abba 23. Pukpuk
- 12. N.B.C. 24. Sua

- 1. Bos kanaka bilong haus masta
- 6. Gutpela (Tok Motu)
- 7. Provsins bilong Stephen Tago
- 8. Singsing bilong Tahiti
- 11. Kaikai maus
- 12. Moni bilong wok
- 13. Defens Fos
- 14. Kote, Kuanua na Suau, em tripela
- 15. Hat tumbuna bilong ol Buka
- 16. — Tedi
- 18. I no yumi
- 19. Tingting planti
- 21. I save bruk long nambis
- 22. Pisin na jambo
- 24. Buk bilong Russell Soabe
- 26. Yu brukim, bai i gat kot
- 27. Ol bikpela haus i gat wanpela long kuk na narapela long slip
- 28. Wanem hap?

Lep i go long rait

- 29. Poro bilong Unggau
- 30. Namba fav mun

- 31. Samting bilong string ben
- 32. Meri i wok long haus sik

Antap i go daun

- 1. I no singel
- 2. Stet solisita bilong PNG
- 3. — gat wok
- 4. Yu ting yu — yet
- 5. Ol ovasis manmeri i kam lukluk raun long PNG
- 6. Bun bilong lip
- 8. Rausim
- 9. Sik i kam long natnat
- 10. Ekting Dairekta bilong Len Transport Bot
- 12. Biktaun bilong F
- 14. Namba tu bilong luluai
- 17. Klostu PNG i gat tenpela nau
- 20. Boluminski, Hiritano, na Hailans, em tripela
- 23. Liklik man o meri
- 24. Wanpela kain admin basket
- 25. Poroman

'85 Championship cancelled-Netball

THE 1985 National Netball Championship scheduled for Arawa at Independence Weekend have been cancelled due to the very high travel cost involved and the failure of netball associations to pay their affiliation fee to the Federation.

To get all the interested teams to Arawa was going to cost K62,000 in airfares alone. Many of our small associations could not afford the K4,500 per team and there are so many

fundraising activities going on in the provinces for Independence celebrations, money is very tight.

In addition to this the failure of associations to pay their affiliation fees, despite having the deadline extended twice has been another deciding factor. By the last deadline of 15 August only two associations had paid in full and another two had made part payments from the thirteen associations previously affil-

iated this response is not good enough.

The Federation Executive has no alternative other than to cancel this year's championship. It is a shame that we have had to reach this stage when netball is really growing throughout the country. Hopefully associations will learn from their slackness in 1985 and make more concerted efforts in the future.

Despite the championships being cancelled enthusiasm in

two regions will ensure that some representative games will be played. Alotau will host matches against Popondetta, Misima and Samarai during Independence Weekend and then on 28-29 September Madang will host a New Guinea Region Tournament involving Senior and U-19 teams from Lae, Madang, Goroka, Wewak and Vanimo.

The Annual General Meeting of the Federation will however still take place because it is

election year and there are a number of important matters that have to be discussed.

The AGM will be held in Madang on Saturday 28 September and all associations are urged to ensure that they have two representatives at this meeting.

Nominations are now open for all positions on the executive and should be received by Jan Waddy no later than 21 September.

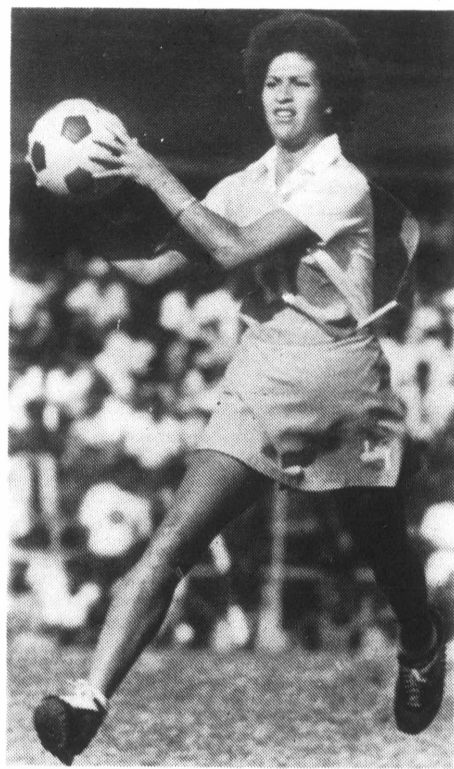

● Marion Walsh, a Netball star in Port Moresby.

Nupela sempian long gren fainal bilong ol meri long Mosbi soka.

Rapatona na Kumul i kamap nupela kwin



"Hei, soka bal, yu kam daun hariap ya." Swipa bilong Blu Kumul Frederica Siwin i mekim dispela tok na redi long hetim bal. Tasol straika, Leila Gilchrist bilong Stone Axe i sambai klostu.

RAPATONA tim bilong Meri long Pul A divisen i kamap nupela kwin bilong Mosbi soka long las wik Sarere. Ol i autim olupela sempian, Waliya, 2-1 insait long hatpela gren fainal resis long Bisini soka oval.

Ben Wauns i raitim

Kepten bilong Rapatona, Nialin Karol i kisim biknem long skoim wining gol na mekim tim bilong em i winim resis. Na kepten bilong Waliya, Ibowato Palo, i tok tim bilong em ilus, bikos ol pilaia i pilai kranki. Tasol Ibowato i tok klia olsem Rapatona i smatpela tim husat i bin resis strong. Na em i orait.

I gat moa long 400 manmeri i kamap long Bisini ples pilai long lukim dispela gren fainal resis.

Insait long Meri Pul B resis, Stone Axe i salensim Blu Kumul. Tasol Blu Kumul husat i lida na maina primia tim long dispela divisen i autim Stone Axe 1-0. Na em i namba wan taim tru long Blu Kumul i kamap soka kwin insait long Mosbi soka, bihain long ol kirapim tim long 1983.

Kepten bilong Stone Axe, Stella Harika i sanap long senta midfil

na pilai strong tru. Em wantaim rait midfilda, Marilyn Gideon, lep midfilda Angela Rani na swipa, Thelma Misirait i trai hat tru. Ol i wok long stapim bal na salim i go long lain straika, Lelia Gilchrist, Stella Erastus na Thelma Manuwadi. Tasol ol dispela straika i no bung gut na kisim bal i go insait long gol eria bilong Kumul.

Insait long namba wan hap bilong pilai, Kumul i banisim mak strong. Sempian fulbek na swipa, Frederica Siwin, Mokato Madabe na Anigi Wowej i lukautim beklain. Ol i bung gut wantaim Sowamato Baley, Pauline Ive na Dyleen Ume long midfil na sapotim lain straika bilong ol. Ol i sapotim straika Anna Seto, Emma Uwato, Elizabeth Mera na Vince Kawalai long ranim bal i go bomim mak bilong Stone Axe.

Ol i pilai strong i go inap long 17 minit mak bilong namba wan hap. Na Anna Seto bilong Kumul i go skoim gol.

Blu Kumul i go pas 1-0 i go inap long haptaim. Tupela tim wantaim i go insait long namba tu hap bilong resis na Stone Axe i hatim bun. Tasol ol i trai hat i go i go na popaia. Na dispela gol bilong Anna Seto i

sanap strong i go inap long fultaim.

Insait long Meri Pul A divisen resis, Veldor Maves bilong Rapatona i putim namba wan gol. Na Densy Sawan bilong Waliya i bekim gol. Tupela tim wantaim i sanap 1-1 i go inap long fultaim.

Ol i go insait long namba tu hap na Rapatona i pilai smat moa. Ol i kisim bal na krungutim eria bilong Waliya. Tasol Julie Bibi, Waisato Bugi, Bilimini Yatamala na kepten, Ibowato Palo i pilai samt tru na rausim bal planti long gol eria bilong ol. Ol i popaia liklik long 21 minit mak bilong namba tu hap na wining gol i kamap.

Nialin Karol i kisim bal na sanap 12 mita longwe long lephan sait bilong net. Em i swingim bal strong tru i go hamaim krosba bilong gol pos. Golkipa bilong Waliya, Omato Bibaesi i ting bal i abrusim krosba. Tasol nogat. Bal i tantanim na sut i go insait long net. Na tok indai. Long wanem dispela gol i sanap strong i go inap long fultaim.

Long namba tri gren fainal resis, Anda 19 tim bilong Westpac i autim Sunam 1-0. Dispela gol i kamap long penalti kik. Na Sunam i sori tru long mekim kamap kranki

pilai na larim Westpac i winim resis isi tru long penalti gol.

Na tupela pilaia husat i winim bikpela sapot bilong olgeta sapota, em lepwinga, David Geame na Golkipa, Ebo Heri bilong Westpac. Dispela tupela pilai i soimaut smatpela stail bilong pilai na trik trik wantaim bal na amamasim ol sapota. Na David Geame tasol i mekim Westpac i kisim penalti kik.

Long 19 minit insait

long namba wan hap, David i bin kisim bal long lepwing na ranim i go insait long penalti eria. Wanpela fulbek bilong Sunam i mekim biksait kik na David i puundaun kranki tru long graun. Reperi i larim penalti kik i kamap. Na swipa bilong Westpac, Hauli Wapo i no popaia long seksekim net. Dispela gol i sanap strong insait long namba wan hap, namba tu hap bilong resis na i go kamap long fultaim.



Nialin i smat moa na helpim tim bilong em long winim Waliya.

The Bill Of Rights For Young Athletes

From PNG Association For Health, Physical Education and Recreation

HERE is good news for Papua New Guineans who love sport and wish to see the young generation develop a high respect and a relatively good standard of sport in senior level some ten years from today.

Compiled by Benny Bogg

The recently established PNG Association for Health, Physical Education and Recreation which John Newton is the president of is all out to encourage children and youths in schools and similar institutions here to employ fair play codes in sport.

This code is adapted from the Canadian Council on Children and Youths' in sport in their country but the association believes that this code is appropriate for our young sportsman and women.

The association sees schools as a vehicle to favourably arrive at the aim of producing proper sports people in the country.

The association has also adapted the widely accepted American Alliance for Health, Physical Education and Recreation's Bill of Rights For Young Athletes" for use by sporting bodies here.

I quote the rights of children in sport as provided by the association.

"All children have the right to:

- participate in a range of sports at a level suited to each child's maturity and ability,
- play as children and not as adults,
- qualified adult leadership,
- participate in a safe and healthy environment,
- share in leadership and decision making,
- proper preparation for participation in sports,
- an equal opportunity to strive for success,

- be treated with dignity,
- have fun in sport,
- be set a good example by senior players, officials and spectators.

Based on these rights is a set of codes of behaviour to serve as a practical guide to reinforce the positive elements of children's participation in sports."

The association has produced a booklet that recites these adapted codes of fair play titled, Position Statement on children in Sport with Fair Play Codes.

The Players Code

1. play for the "fun of it," not just to please your parents or coach.
 2. play by the rules.
 3. never argue with the officials' decision. Let your captain or coach ask any necessary questions.
 4. control your temper - no "mouthing off," throwing bats or other equipment.
 5. work equally hard for yourself and your team - your team's performance will benefit, so will your own.
 6. be a good sport. Cheer all good plays, whether your team's or your opponents'.
 7. Treat all players as you yourself would like to be treated. Don't interfere with, bully or take unfair advantage of any player.
 8. Remember that the goals of the game are to have fun, improve your skills and feel good. Don't be a show-off or always try to get the most points or penalties.
 9. co-operate with your coach, teammates and opponents, for without them you don't have a game.
- Wantok Sports will bring out codes for others who do have some influence on sport in general in the next issues. Keep in touch.

Madang soka fainal husat bai win?

Ari Aba i raitim

BIKPELA semi fainal resis bilong Madang soka bai kamap long neks wik Sarere, 21 Septemba. Bai gat maina semi fainal resis namel long Admiralty na Panafun meja semi fainal pilai-bai kamap namel long EPC na Momase.

Poin lata i soim Momase na EPC i bung long namba wan ples wantaim 25 poin, Admiralty 24, Panafun 22, Mimlon 16, Luteran Yut 16, Guria 15, Tarangau 14 na Aigob wantaim Murat 6 poin.

Long dispela wik eksekutyutiv komiti bilong asosiesen i wok long painimaut ol poin namel long Momase na EPC. Long wanem tupela i gat 25 poin. Ol i laik painim sempian tim husat i gat planti gol na mekim em i kamap maina-primia bilong primia divisen kompetisen.

Momase i sempian primia divisen tim long yia, 1983. Tasol ol i popaia long las yia. Ol i laik kisim bek taitel long dispela yia, tasol ol i mas autim EPC pastaim.

Vais keptem bilong EPC, Alfred Gabon tok ol i no inap bungim hevi insait long semi fainal resis. Long wanem ol king long las yia. Na ol bai win gen nau. Ol i gat sempian

straika, Phillip Posanau, Murray na Albert wantaim sempian golkipa, Phillip Kam.

EPC i mas was gut. Long wanem Momase i gat lain sta pilai olsem Andrew Tukiki, John Wamari, Kenny Beki, Bobby na Paul Kuno, Na Momase i bin autim EPC 2-0 tupela wik bipo na autim Admiralty 2-1 tu.

Kepten bilong Admiralty, Bobby Morrie i tok em i gat planti ekspiriens straika na pilai husat inap autim Panafun. Na ol bai go het tu long gren fainal pilai. Admiralty i kamap king bilong Momase kantri soka sempiansip resis namel long tripela yia bipo. Long wanem ol i gat smatpela lain straika olsem Oscar Sisii, Steven Simon, Andrew and Steven Dorr wantaim biknem golkipa, David Sitol.

Tasol wanpela tim Admiralty i gat bikpela pret long en, em EPC. Ol narapela tim i no strong olsem EPC. Na Admiralty i bilip ol i gat bikpela sans long lukim EPC insait long gren fainal, sapos ol i autim Panafun na Momase.

Panafun em asples tim gat lain pilai bilong Yabob, Kranget na Karasin ailan. Nau em i namba wan taim tru long ol i go insait long fainal resis.

BUILD IT YOURSELF!

Pacific Awara or Hohola.
All three Bedroomed Homes.

- One container with your above selected home, will be shipped to you at the nearest port of entry.
- Very, very easy instructions to build inside each container.
- Just pick up container with transport and transfer to your land. All customs duty paid.

Being a high covenant home your savings will be between K20,000 to K30,000.

For more information now,
Phone: 21 1575 BH, 21 7183 AH.
AUSTROASIAN STEEL AND CASEY KAY PTY. LTD.
P.O. Box 482, Port Moresby.

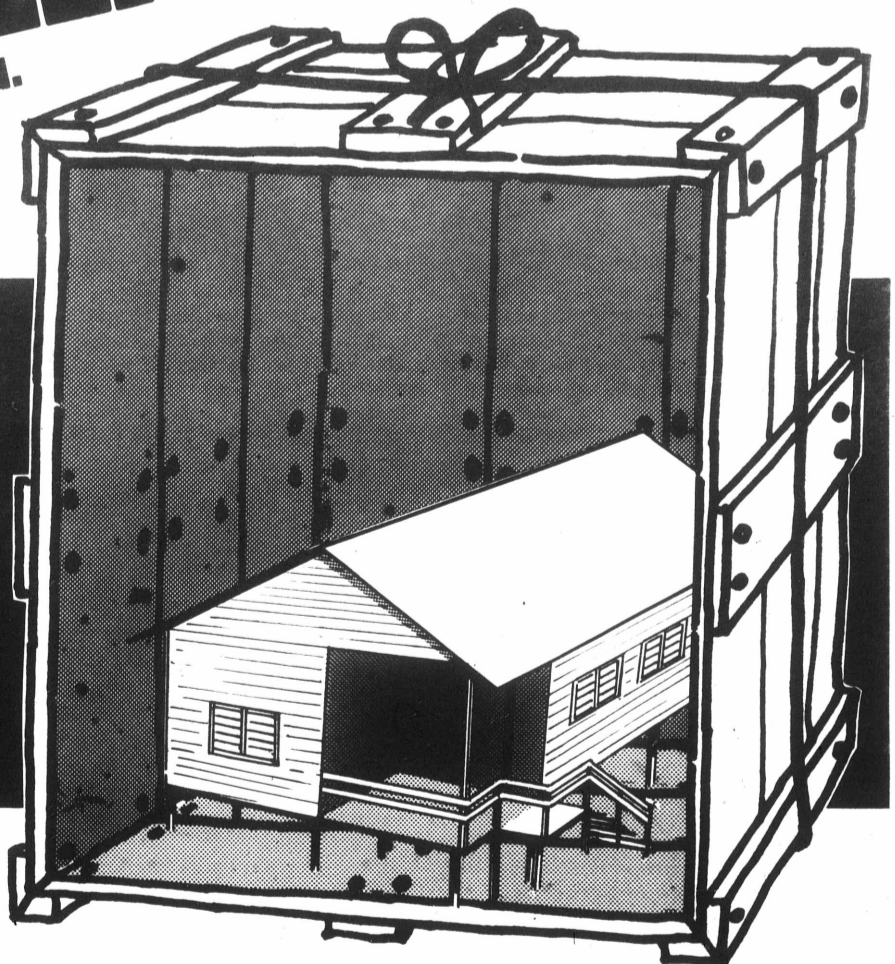

HRD 6090

Madang Norths Hoki Sempian

OL meri Norths i kamap nupela kwin long Madang hoki resis. Ol i hamaim Sunam 4-0 insait long gren fainal pait insait long Divair Wot ples pilai long las wik Sande.

Ari Aba i raitim

I gat 500 pipel bilong Madang taun i kamap na lukluk long dispela resis. Pilai i kirap long 2 klok apinun. Na sempian hap bek bilong Norths, Elsie Kosi i skoim

namba wan gol insait long 8 minit bihain long pilai i kirap. Elsie Kosi wantaim Rose Manu, G. Sual na kepten, Alexia Tare i strongim midfil eria bilong Norths. Golkipa Margaret Kisani i bosim mak na A. Bike wantaim J. Eleka i spaotim em long lukaotim goleria. Na lain straika, Leslie Kulala, Margaret Duguman, Juno Ena na L. Mika i wilwilim hoki stik long fowatlain.

Long 8 minit gen bihain long haptaim,

Margaret Duguman i putim namba tu gol bilong Norths.

Long narapela 12 minit, tupela sait i wilwilim stik na ranim bal long wanpela kona i go kamap long narapela sait. Sunam i mekim kain kain smatpela trik long traim bekim dinau. Tasol ol meri bilong Madang na Morobe Provins insait long Norths tim i no kaunim ol dispela trik.

Margaret Duguman, Leslie Kulala, Juno Ena wantaim Mika i wok long hatim pilai na pulim bal i go bomim mak bilong Sunam planti taim. Na no longpela taim bihain, Margaret Duguman i skoim namba 4 gol bilong Norths.

Insait long gren final resis bilong man, Luteran Yuts i autim Sunam gen long 1-0. Dispela skoa i kamap long penalti hit tasol. Sapos Sunam ino asua, planti sapota i bilip bai ol i dro 0-0, 1-1, na skruim pilai i go yet. Long wanem tupela tim i kamap kain resis bilong strongim mak tasol. Na ol i save larim tupela man i trai hat long abrusim birua na skoa.

3rd Divison League ladder after weekend 7th and 8th September, Port Moresby, 1985

TIM	P	W	D	L	F	A	P
Golo	23	18	4	1	102	36	39
Buresong	23	16	5	2	86	23	37
B.F.C.	23	16	2	5	68	38	34
Westpac	23	14	4	6	66	29	31
YMCA	23	12	8	4	61	27	31
Wanzesi	23	12	6	4	69	23	30
Guria	23	11	5	7	48	35	26
V.R.F.C.	23	8	4	11	38	56	20
Sunam	23	6	4	13	38	63	16
Stone Axe	23	5	6	12	25	43	15
Palit	23	6	2	15	31	43	14
Kwasis	23	5	1	17	30	77	10
Bunbun	23	3	3	17	23	83	9
Batu	23	2	2	19	23	102	6

Taim	Gret	Tim	2.15	Prim	Sunam V Taramgai
			4.15	Prim	Rapatona V G.F.C.
WIK 21					
SARERE 14 SEPTEMBER, 1985					
BISINI 1					
9.30	2nd	Boand V Faze	9.30	2nd	Boand V Nomads
11.00	2nd	L.S.C. V Nomads	11.30	1st	Guni V Kiriwina
12.30	2nd	Tarangau V Kusebo	12.00	1st	Baba V Waliya
2.15	1st	Kula V Kiriwina	2.30	Prim	Westpac V Wanzesi
4.15	1st	Guni V Baba	4.15	Prim	B.Kumul V G.F.C.
BISINI 2					
9.30	2nd	Mokawa V Kadakada	9.30	2nd	PNGDF V L.S.C.
11.00	2nd	Pailou V Rapatona	11.00	1st	Kula V Ali Utd
12.30	1st	A.Niugini V Waliya	12.30	Prim	Sunam V Rapatona
2.15	Prim	Wanzesi V G.F.C.	2.15	Prim	N.Defence V Morobe Utd
4.15	Prim	Westpac V Rapatona	4.15	Prim	Tarangau V Guria
G.F.C.					
10.00	3rd	YMCA V Batu	10.00	2nd	Faze V Kusebo
11.30	3rd	Sunam V B.F.C.	11.30	2nd	Tarangau V Togelu
1.00	3rd	Guria V Stone Axe	1.00	2nd	B.Kumul V Rapatona
2.30	2nd	Jevaha V PNGDF 2	2.30	1st	A.Niugini V L.Youth
4.15	2nd	B.Kumul V Togelu	4.20	1st	Ilimo V Sobou
MURRAY BARRACKS					
12.00	4thB	Lukan V Losegu	12.00	3rd	Batu V V.R.F.C.
1.30	4thB	Tokana V Sabam	1.30	3rd	Y.M.C.A V B.F.C.
3.00	4thB	Tara V Butavi	3.00	3rd	Sunam V Stone Axe
4.30	4thB	Gomba V Mapos	4.30	3rdB	Wanzesi V Bunbun
SANDE 15TH SEPTEMBER					
BISINI 1					
9.30	3rd	Golo V Bunbun	12.00	3rd	Golo V Palif
11.00	3rd	Westpac V Buresong	1.30	3rd	Westpac V Kwasis
12.00	1st	Ilimo V Ali Utd	3.00	2nd	Jevaha V Kadakada
2.15	1st	Maegin V Sobou	4.30	1st	Milne Bay V Maegin
4.15	1st	Milen Bay V L.Youth			
BISINI 2					
9.30	3rd	Kwasis V Palif			
11.00	3rd	Wanzesi V V.R.F.C.			
12.30	Prim	B.Kumul V Morobe Utd			
2.15	Prim	N.Defence V Uni			
4.15	Prim	Guria V Sunam			
G.F.C.					
11.00	4th	Makamaka V Palif			
1.00	4th	Maniota V P.T.C.			
2.30	4th	Yabwau V Momase			
4.15	4th	K.E. Izuzu V Katumani			
MANDE 16TH SEPTEMBER					
BISINI 1					
2.15	3rd	Mokawa V Pailou			
4.15	Prim	Morobe Utd V Wanzesi			
BISINI 2					
12.30	2nd	Guria V Buresong			

Premier Uni — BYE

Notification to all clubs/teams affiliated to P.M.S.A.

At the executive committee meeting on Monday 9th September 1985 it was decided that should there be any further occurrence of spectator, club official or player abusive behaviour towards any officials acting on behalf of P.M.S.A., then all games will be suspended for the 1985 season.

We regret that this decision has had to be taken, particularly because the majority of clubs are well disciplined and spectators/supporters well behaved, and we take this opportunity to thank those clubs for their support.

Nesenel hoki sempiansip

MOA long 20,000 pipel bilong Not Solomons Provins bai bung long Arawa namel long dispela longpela Independens wiken. Long wanem bai gat bikpela Not Solomons spot kanival na Nesenel hoki sempiansip resis i kirap long Fraide, 13 Septemba i go inap long Mande, 16 Septemba.

Ben Wauns i raitim

Presiden bilong Arawa Hoki Asosiesen, Mista Kasan Chapang i tokaut olsem 4-pela senta - Mosbi, Lae, Manus na Arawa - bai resis insait long hoki sempiansip. Mosbi, Lae na Manus bai kamap wantaim wanpela tim bilong man na wanpela tim bilong meri. Na Arawa bai putim kamap tupela tim bilong man na tupela tim bilong meri. Long wanem Madang, Popondetta na Goroka i no inap kamap long resis.

Chapang i tok klia olsem em i namba wan taim tru long hoki tonamen i kamap long Not Solomons Provins. Na planti manmeri bai pulap long Arawa taun long lukim pilai. De bilong opim hoki resis na provinsal spot kanival bai kirap wantaim long Fraide moning. Dispela bung i kamap namel tu long taim bilong amamasim Namba 10 Yia bilong Independens.

Em i tokaut tu olsem hoki tim bilong Mosbi na Manus bai slip long Arawa Haiskul. Na Lae skwat bai slip long Savlon Kalap long Loloho.

Dispela Savlon Klap i stap 8 kilomita long we long Arawa ples pilai. Tasol i gat olgeta rot bilong transport i stret pinis. Chapang wantaim asosiesen bilong em bai lukaotim ol arapela senta long haus slip, transport na kaikai.

Arawa Entaprais Limitet em i wanpela spot stua kampani husat i spona long lukaotim dispela tonamen tu. Na ol i givim helpim long lukaotim ol pilaia na putim kamap prais bilong resis. Narapela lain husat i givim han tu em Nesenel Fitness Klap (Nafit) bilong Arawa. Ol bai givim hoki pos, net, plak na arapela samting bilong hoki pilai i go long hoki resis.

Chapang i tok Arawa hoki tim i save stap aninit long sempian hoki senta, Lae, Mosbi na Manus long planti sempiansip resis bipo.

Tasol nau, bai Arawa i kisim bikpela sapot bilong asples sapota. Na arapela senta i no ken kirap nogut, sapos Arawa tim 1 o tim 2 bilong man o meri i kisim taitel long dispela yia.

Lae skwat husat i kisim taitel long las yia bai trai hat long holim pasim taitel. Mosbi i no bin kamap long sempiansip resis long las yia. Na ol i promis long autim taitel na karim i go bek long Nesenel Kapital Distrik nau. Tasol Manus tim i gat wankain tingting tu, long mekim taitel i anka long maus bilong Chauka.

Hia em i Nesenel hoki sempiansip dro-



Ol sempian meri bilong Madang, Norths, i wim pinis long Madang Hoki. Ol smat tru ya! Olsem na ol i kisim nem "Kwin bilong Madang" tru o?



Lutheran Yia tim bilong Madang i autim pinis sil bilong gren fainal.

**TIME FOR A SING SING
TO WELCOME OUR NEW FORD**

1985 COURIER 1985



NIUS

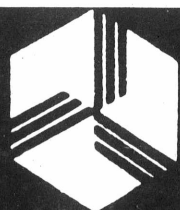

Meridien Motors

PORT MORESBY 25 2477

LAE 42 2869



PRETORIA - SAUT AFRIKA: — Bisop Desmond Tutu i toktok wantaim ol niusmar biham long wantaim lain bilong Yuropan Ekonomik Komuniti (EEC) i bingoraim long Saut Afrika. Bisop Tutu i bin tok olsem Saut Afrika bai bagarap klostu na nau em i taim bilong stretim ol santim i wok long kamapim dispela hevi. Dokta Beyers Naude, jeneral seketeri bilong Saut Afrika Kaunsil bilong ol Sios i sanap long rathan.

Antap — Lephon

MADRID - SPEN: — Jose Labero i bin dai biham long wantaim buhnikau i bin sutim em. Papa na mama bilong em i wok long lukluk i stap long bodi bilong em bipo long ol planim em.

TYRE - SAUT LEBANON: — Ol kam bilong Lebanon na Palestani em ol soldia bilong Israeli i em larim ol i go tri i amamas tru long taim ol i lusim haus katabus. Israeli em larim 113 katabus long Atlit haus katabus i go gri.

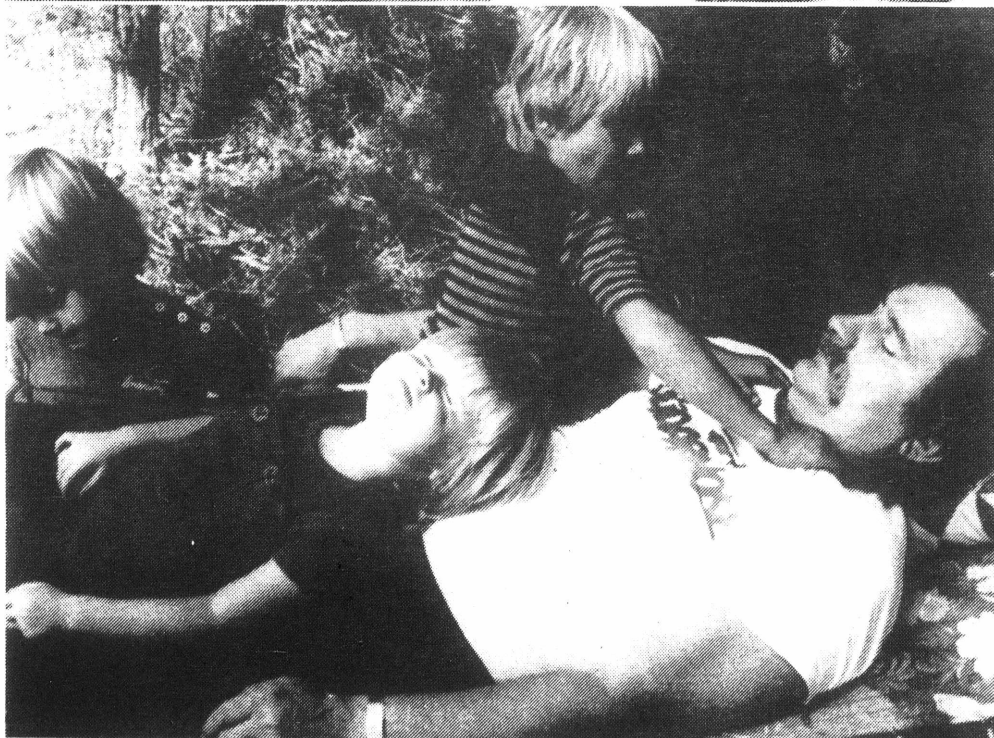

GDANSK — POLAN: — Lida bilong Solidarity Fri Tred Yunion, Lech Walesa i malolo i stap wantaim ol tripela pikimini bilong em. Long 31 Ogas i bin i gat ol bikpela seremoni long makam namba 5 via bilong dispela yunon bilong ol.

STOKHOLM - SWIDEN: — Misis Britt-Marie Hagberg i sanap insait long haus bilong em we wantaim roket bilong bahus i bin pundain na bagarap. Tupela bahus bilong pait i bin ban antap long skai na hap roket bilong wantaim i pundain i go daun na bagarapim haus va.

CO-AIR
Co-ordinated Air Services Pty. Ltd.

**OWNED BY
PAPUA NEW GUINEANS
WORKING FOR
PAPUA NEW GUINEANS**

DAILY FLIGHTS FROM LAE TO					
BAINDONG BAWAN DERIM INDAGEN	KABWUM KASANOMBE KONGE LENGBATI	LOWAI MAKINI MASA MINDIK	OGERANANG PINDI SAPMANGA SAMANZING	SATWAG SIULUM SIWA WASI	YAFUMELI
MONDAY	TUESDAY	WEDNESDAY	THURSDAY	FRIDAY	SATURDAY
MENYAMYA ASEKI	FINSCHHAFEN SIASSI LABIAB	MENYAMYA ASEKI	FINSCHHAFEN LABIAB SIASSI	LABIAB KIUNGA	FINSCHHAFEN LABIAB SIASSI MENYAMYA ASEKI
SCHEDULED SERVICE					

**AVAILABLE FOR CHARTER
THROUGHOUT PNG**

CONTACTS:
LAE — 42 3783, 42 3707, 42 3080.
A/H MANAGER J. WIELNS 42 3158.
CHIEF PILOT T. ZADOW 42 1364.
WAU — 44 6241
FINSCHHAFEN — 44 7019, 44 7049

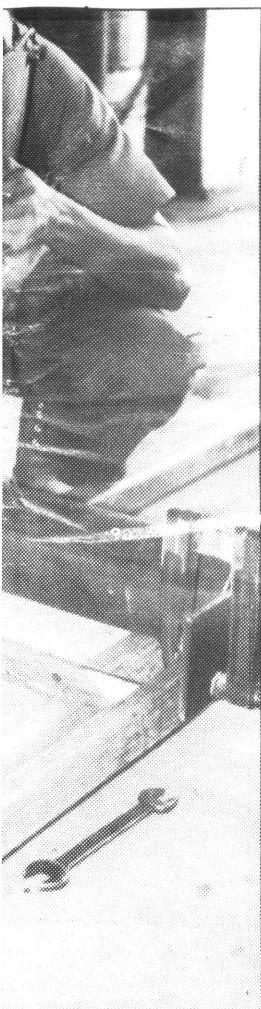

TURE



SUPPLY



INSTALL

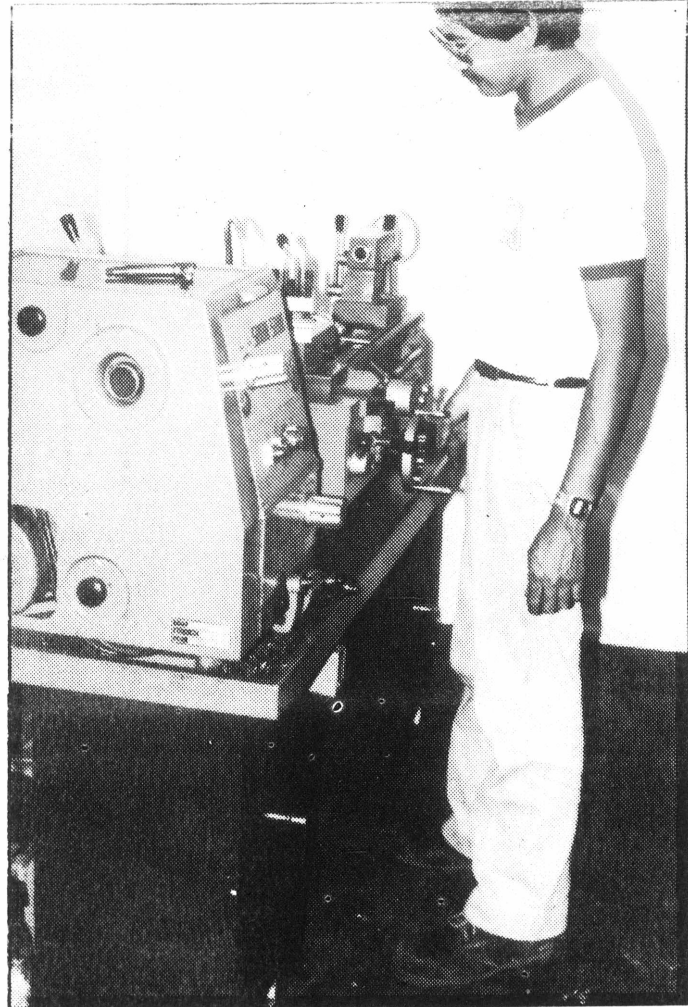
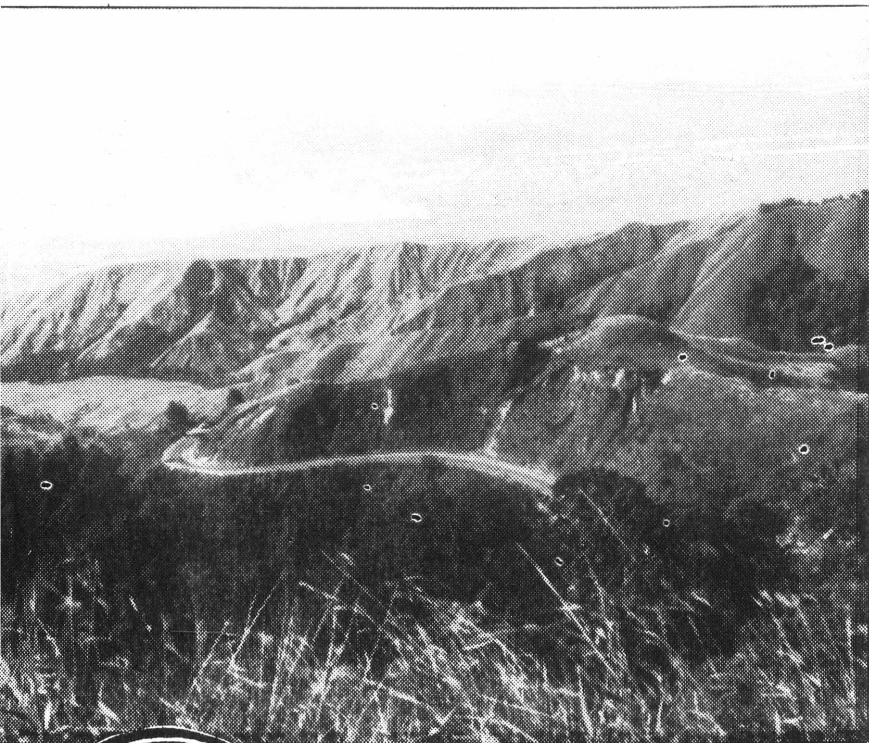

SERVICE



NGPS

Pastoral - Industrial

New Guinea Pastoral Supplies Pty Ltd

P.O. Box 83, LAE.

Phone: 42-2635 (5 lines)

Telex: NE 44188

o Pty Ltd

Invest in gold.



Wantok

Digitized version made available by



Copyright: Under copyright

Rights Holder: Word Publishing Company Limited

Use: This digital version is made available from the UC San Diego Library under a license granted by the Word Publishing Company Limited. This digital copy of the work is intended to support research, teaching, and private study.

Constraints: This work may be protected by copyright law. Use of this work beyond that allowed by the applicable copyright statute requires the written permission of the copyright holder(s). Responsibility for obtaining permissions for any use and distribution of this work rests exclusively with the user and not the UC San Diego Library. Inquiries can be made to the UC San Diego Library program having custody of the work.

Note on digitized version: Some of the digital versions presented here reflects the quality and contents of the microfiche. Problems which have been identified include misfiled or out-of-order pages, illegible text; these problems have been rectified whenever possible.