

# Insait Long Wantok

# Wantok

Namba 517 — 28 Epril inap 5 Me, 1984

25¢

## Narakain Bebi Long

## Kimbe Haus Sik

I GAT wanpela narakain bebi husat i gat sem bilong man na sem bilong meri long bodi bilong em i slip nau long Kimbe Haus Sik, Wes Nu Briten Provins. Na mama i karim dispela bebi long las wik

Fonde, Epril 19, 1984.

Rait ai bilong dispela bebi em i op pinis, tasol skin i karamapimlep ai bilong em i no op yet.

Long 6-pela mun bihain bai wanpela dokta bilong sekim ai

insait long Nonga Haus Sik long Rabaul i go sekap long ai bilong dispela bebi, sapos lep ai bilong en i no op yet.

Tasol long tude, dispela bebi i wok long slip gut i stap long Kimbe Haus Sik. Na i no gat sik

i bagarapim skin o bodi bilong em. Dispela sem bilong man na meri wantaim i stap long bodi bilong em tasol i asua.

Papamama bilong dispela bebi i bilong Menyamya Distrik long Morobe Provins. Tasol ol i stap nau long Kavui Wel Pam Blok klostu long Kimbe.

## Solomon Ken Soim Rot

**PRAIMERI** Indastri Minista Dennis Young bai go pas long wanpela lain bilong PNG husat bai go lukluk raun long pis faktori long Solomon Ailan.

Praim Minista Michael Somare i bin tokaut long dispela samting

bilong em i kam bek long lukluk raun bilong em long Solomon Ailan.

Mista Somare na ol lain bilong em i bin lukim tin pis faktori long Tulagi long Westen Distrik bilong Solomon Ailan. Na Mista Somare i tok Papua Niugini i gat planti samting long lainim long dispela pis bisnis long

Solomon.

Em i tok, Papua Niugini i wok long toktok long kirapim tin opis faktori long planti via nau tasol i kam inap nau no gat wanpela samting i kamap."

Em i tok tu olsem dispela ol pis ol i kisim long solwara bilong

Solomon em i wankain olsem ol pis ol i save kisim hia long PNG.

Na em i tok sapos Solomon Ailan i gat wanpela gutpela pis bisnis orait, i no gat wanpela samting i pasim rot bilong PNG long kirapim wankain samting hia long kantri.

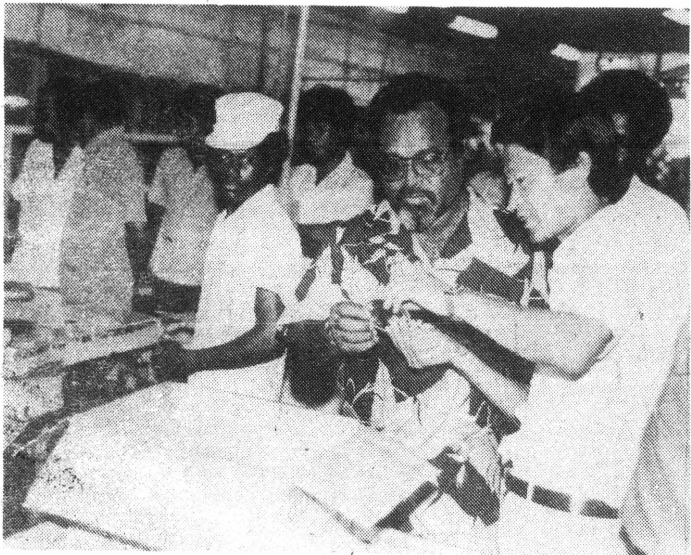

• Praim Minista, Michael Somare i lukluk raun long tin pis faktori long Tulagi, Solomon Ailan.

### Insait

- Indonesia Bekim Ol Askim - pes 4
- Tingting Bilong Mochtar - pes 2
- Moa Refuji Kam - pes 2
- Anzac De - pes 3
- Pas - pes 6, 20, 21.

## NUPELA

RUGBY LEAGUE  
4-PAGE PULLOUT



Olgeta wik bai Wantok Niuspepa i bringim Ragbi Lig nius i go long ol pipel bilong Papua Niugini. Putim ai long namba wan Rugby League News, em bai kamap insait long Wantok Niuspepa long neks wik.

## HARA KAP



Moses Murray bilong Yunivesiti tim i amamas long holim gen Hara Kap tropi bilong dispela yia. Yunivesiti i bin autim dispela kap na em i namba 9 taim nau long Yunivesiti i holim dispela soka kap long Mosbi.

## Karim Kros



Ol pipel bilong Wabag daiosis long Enga Provins i karim wanpela kros raun long daiosis bilong ol. Na bihain bai ol i karim i go kamap long Hagen 1-pela de bipo long Pop Jon Pol i kamap long Hagen.

PEANUT  
COCONUT  
CHOCONUT  
CHOCOLATE



Paradise

COOKIES

48  
72  
23/v. 517



# Tingting Bilong

## Mochtar

**HUW:** Inap yumi lukluk long dispela toktok em i pulim ai bilong Australi na PNG.

Mi tok long ranawe bilong ol Irian Jaya refuji i kam insait long PNG.

Indonesia i gat wanpela bikpela program long muvim ol pipel bilong Indonesia i kam long Irian Jaya (Transmaigresen).

*Yu ting bai ol pipel bilong Irian Jaya i no laik na les long ol pipel bilong Indonesia o Saina i kam sindaun wantaim ol. Yu ting dispela bai bringim trabel long Irian Jaya?*

**DR. M:** Olsem mi ting mi save bilong wanem ol pipel bilong Irian Jaya i no laik sindaun wantaim ol Indonesia, na mi save olsem mipela i lukluk gut na wok long stretim dispela wari.

Na mi bilip strong olsem ol pipel i kamap long Irian Jaya i wok long go pas long kirapim pit. I luk olsem planti bilong ol dispela pipel i tingim promis bilong olupela kolonial gavman bipo long givim independen bihain long ol. Ol i snap strong wantaim dispela olupela bilip, olsem na ol i go het long pit yet.

Na dispela ol trabel i sut stret long aslo bilong olupela gavman long bipo. Long dispela as, mipela i mas stretim dispela asua aninit long politikal tingting.

**HUW:** Bai yu tok klia long ol pipel bilong Wes Irian long dispela hevi olsem wanem? Bikos bai ol i kamap liklik lain grup husat ai no inap i gat pawa long mekim sampela samting insait long dispela ples ol i bin lukim olsem graun tru bilong ol. Na bai yu tok klia long dispela samting i gutpela long helpim ol olsem wanem

tru?

**DR. M:** Mi no ting dispela samting bai tambuim ol Wes Irian pipel long ranim sampela wok insait long graun bilong ol. Bai gat sans long olgeta pipel i bung na ranim wok. Em i gutpela ansa bilong stretim hevi i kamap namel long dispela tupela lain pipel. Tasol ol pipel i no inap ranim wok nating. Ol i mas kisim kain save inap long larim ol i ranim wanpela bikpela wok.

Dispela hap samting tasol i gat asua. I gat sotpela taim. Na bai no gat bikpela taim long larim ol dispela asples pipel i kisim skul o trening bilong mekim wok. Taim i sot. Dispela asua i no gat wanpela isi rot long stretim.

**HUW:** Bai yu bekim tok bilong wanpela Minista insait long PNG gavman olsem wanem? Dispela Minista i tokaut olsem em i gat bilip bai Indonesia i lukluk gen long kirapim dispela kam pasin insait long PNG long 20 via bihain.

**DR. M:** Mi ting dispela toktok i no gat gutpela as bilong en. Long wanem mipela i gat bikpela hap graun long Kalimantan we i no gat planti pipel i pulap long en tude. Na i no gat gutpela as tru long mipela i kalap i go long PNG na kirapim kain kain belhevi na kisim trabel long han bilong mipela yet.

**HUW:** Yu bin kirap nogut long harim dispela maus bilong Minista bilong PNG o olsem wanem?

**DR. M:** Yes. Bikos mipela i no gat wanpela liklik tingting long mekim dispela samting em i tokaut long en. Na dispela Minista tu i kirap nogut long painimaut olsem toktok bilong em i abrus tru.

**HUW:** Em i bin kirap nogut long Praim Minista bilong em yet i makim maus bilong yupela na bekim toktok bilong em, a?

**DR. M:** Mi no save, olsem na mi no inap tok klia long dispela samting.

**HUW:** Yu tok olsem PNG i no ken wari long ol samting olsem rot em Indonesia i wokim go insait long kantri bilong ol na ranawe bilong ol refuji i go long graun bilong ol?

*Olsem mi tok long sampela handet manmeri refuji husat i stap nau long PNG.*

**DR. M:** Oh, yu toktok long ol refuji. Em ol yet i ken pret nating na ranawe abrusim boda. I no gat bikpela wari long Irian Jaya. Nau mipela i stretim pinis long toktok bilong boda. Tasol mipela i no gat tingting long go insait long PNG.

**HUW:** Yes tasol.....

**DR. M:** Nau o long taim bihain?

**HUW:** Dispela program bilong yupela (Transmaigresen) yu ting em bai bringim moa trabel na salim moa refuji i go insait long PNG?

**DR. M:** Transmaigresen program bilong mipela bai mekim ol pipel i sindaun gut. Mipela laik mekim ol i wok long lukautim ol enimal na abus na groim gutpela gaden kaikai na wok egrikaisa.

**HUW:** Planti toktok i kamap egensim yu, taim yu tok long lukautim kalsa bilong Irian Jaya, na yet, yupela i no lukautim gut ol enimal bilong yupela banis bilong ol.

**DR. M:** Nogat. Kalsa i save senis na mi ting em i rong long yumi tok olsem kalsa bilong ol pipel i mas no ken senis. Yes, yu ken askim tu sapos em i impoten long no ken sensim kalsa. Tasol mipela i senis nau - maski yu laikim tingting bilong mipela o nogat.

Wanem samting mipela i mekim long Irian Jaya em long bringim nupela pasin bilong Indonesia long ol pipel. Na mi no ting em i rong. Dispela wok em i hat, tasol mipela mas wok isi. Mipela laik wok isi na no ken bagarapim kalsa o laip bilong ol pipel yet.

Tasol mi ken tok stret long yu, ol Irian Jaya bai no ken bagarap olsem ol blakman bilong Australia. Ol Irian Jaya bai kamap hap bilong Indonesia stret.

Bikos ol gavman bilong bipo ating promisim ol Irian Jaya olsem ol bai kamap independen kantri, dispela i bagarapim sindaun bilong ol.

Mi tu mi no bilong Indonesia stret, tasol nau mi senis na klostu kamap olsem ol pikinini bilong mi tu i kamap klostu moa long Indonesia. Ol papamama bilong mi na tumbuna bilong ol i narakain olgeta olsem ol Indonesia.



**Olpela Foren Minista bilong PNG Noel Levi i sindaun toktok wantaim Dokta Mochtar.**

## INDONESIA LUKSAVE

**INDONESIA** i luk olsem ol i wok long slo daun liklik nau long mekim planti toktok na trabel long ol pipel bilong Wes Papua o Irian Jaya.

Long taim Foren Afeas Minista bilong Indonesia, Dokta Mochtar i wok long toktok long wari bilong PNG na Indonesia long boda, em i bin mekim sampela toktok tu long soim olsem ol pipel bilong Irian Jaya i save gut long as bilong wanem na Indonesia i wok long putim sampela pipel bilong ol i go sindaun long Irian Jaya Provins bilong ol.

Mista Mochtar i tok olsem, long katim daun kros bilong ol pipel bilong Irian Jaya, Gavman bilong Indonesia i ken lukluk long ol pipel bilong Irian Jaya yet long ranim kain kain wok bisnis na gavman long provins bilong ol.

Em i wok long kamapim ol dispela toktok, long taim ABC-TV brotkas stesin bilong Australia i wok long askim em long ol samting i wok long kamap long Indonesia na PNG.

Ol wokman bilong Australia ABC-TV i bin katim daun toktok na kisim piksa bilong em taim em i wok long toktok long Jakarta long mun Mas. Tupela brotkas opisa na wanpela niusman bilong ABC, Huw Evans i bin go long Indonesia na toktok wantaim Dokta Mochtar.

Dispela em i namba wan taim tru bihain long planti yia i go pinis, em Indonesia i bin larim ol niusman na kamera man bilong ABC long go long kantri bilong ol. Na tu em i namba wan taim long ABC niusman i toktok longpela taim tru wantaim wanpela biknem minista bilong Indonesia. Dispela nupela pro-

gram bilong ABC em ol i kolim "Presa Poin" i bin stat long Epril 26, na bai kamap long olgeta Fonde nait long 9 klok. Toktok bilong Dokta Mochtar long Indonesia na PNG wari bai stat neks wik, bihain tasol long Praim Minista bilong Australia, Bob Hawke i mekim namba wan toktok long dispela program.

Sampela toktok bilong Dokta Mochtar i no soim olsem Indonesia i wok long slo daun long trabel, Mochtar i tok klia olsem Indonesia laik kisim Irian Jaya na mekim em i kamap hap bilong kantri bilong ol.

Long taim em i toktok long PNG, Mochtar i tok olsem Indonesia bai no inap kam insait long PNG. Nogut bai planti paul toktok na pasin i mekim longlong tingting bilong ol pipel bilong Indonesia na PNG na bai kamapim planti belhevi bilong ol yet.

## MOA I KAM YET

I gat 102 pipel moa bilong Irian Jaya i kisim kanu na kalapim boda i kam kamap long Vanimo namel long Ista Holide wiken. Ol dispela lain pipel i kisim kanu na go sua long Vanimo namel long las wik Fonde na dispela wik Tunde.

Ben Wauns

Long las wik Fonde, em 14 pipel, Gut Fraide - 32 pipel, Sarere - 11, Sande - 10, Mande - 20 na Tunde em 15 pipel. Planti bilong ol dispela lain em ol meri na pikinini wantaim wan wan man tasol.

Ol dispela Irian Jaya pipel i tokaut long lain opisa bilong Vanimo Helt Divisen olsem bikpela birua insait long asples bilong ol

i pretim ol na ol i ranawe.

Ol i tok olsem lain soldia bilong Indonesia ami i raun long wan wan viles na sekap long manmeri bilong wan wan haus. Ol dispela soldia i askim ol pipel long wanem sait ol i givim sapot long en, em Indonesia o OPM?

Na ol dispela soldia i pretim ol manmeri na pikinini na tok lukaut long katim pinga, han o lek bilong ol, sapos ol i sapotim OPM. Sapos ol man o meri i tokaut long sapotim Indonesia, bai soldia i larim ol i stap isi. Dispela kain pasin i pretim ol pipel tru na planti lain famili i lusim asples na ranawe i go hait long Ista Holide wiken.

Namba bilong ol Irian Jaya pipel i

stap long Blakwara Kem klostu long Vanimo, em i 680. Na long Yapsi, Telefontim em i 150, Kembu 259, Vanimo 102 na long Mamamura insait long Amanab Distrik, em i 300. Tasol i luk olsem planti bilong ol dispela pipel i wok long kam insait long Kembaratoro na Mamaura yet.

Dispela samting i soimaut olsem i gat moa long 1,400 Irian Jaya pipel i stap nabaut insait long bikbus bilong Wes Sepik Provins nau.

Ol wokman bilong PNG Foren Afeas Dipatmen long Vanimo i wok hat tru long lukautim ol dispela pipel long blakwara kemp wantaim kaikai na kios. Na wanpela Helt Divisen tim bilong Vanimo Haus Sik i helpim long givim

marasin oltaim long ol sikmanmeri insait long kem.

Long dispela wik Trinde, i gat kibung bilong wanpela Helt Komiti long Vanimo Haus Sik. Na astingting bilong dispela kibung i bilong stretim toktok na askim PNG Gavman long salim medikal tim bilong en i go givim han long dispela medikal tim bilong Vanimo Haus Sik.

Nau dispela tim long Vanimo iyusim taim bilong wok long helpim ol dispela ranawe pipel long kem. Tasol em i no wok bilong ol. Na PNG Gavman yet i mas salim medikal tim husat i ken wok fultaim long lukautim ol dispela Irian Jaya pipel long ol kem insait long Vanimo.





# Kieta Kibung

**SAMPELA bikipela samting i stap long Ajenda bilong kibung bilong kabinet long Kieta em Foren Minista Mista, Rabbie Namaliu bai givim ripot bilong em long ol dispela kibung long Jakarta, Indonesia.**

Em i bin kibung wantaim Foren Minista bilong Indonesia, Dokta Mochtar Kusumaadmatja long ol hevi bilong West Irian refuji i stap long PNG, na 2-pela jet balus bilong pait bilong Indonesia i kamap long Grin Riva, Ami man, Kenel Sebastian Ismaeil i lusim PNG i go bek, toktok bilong pailot Werner Wyder na samplea moa i kamap long dispela kibung long Jakarta.

Pauline Laki

Minista Namaliu i bin sambai long i go long Fiji long, Tunde, 24 Epril long i stap insait long LOME kibung, tasol em i go pastaim long givim ripot bilong em i go long kabinet pastaim.

Kabinet lukluk moa long Rose Kekedo long ol bagarap i kamap long Dipatman bilong Wok Saplai. Em ripot i tok bikipela mani i lus nating.

Halla Risos Kampani bilong South Korea long mekim wok bilong Vanimo timba Projek bai narapela samting kabinet i glasim gut tru gen.

Okinawa fis kampani long Japan long i kam mekim fis projek, em long painim na katim ol fis putim long ol bikipela bak stoa bokis ais na salim nabaut i go long ol narapela senta long kantri. Dispela Praimeri Industri Minista, Mista Dennis Young i putim dispela i go long kabinet.

Dispela em sampela long ol bikipela samting kabinet bai stretim.

Na taim Mista Somare i kamap long ples balus long Kieta long Kumul 2 eksekutiv balus bilong gavman, Primia Leo Hannett i sambai i stap tasol long ples balus. Na ol pipel long Kieta i welkam long em na Pati bilong Praim Minista i narakain tru long pasin i kamap long Morobe, we ol i tok nogat ol bikman i sanap long welkam long em.

Ol bikman na lida

bilong Tret Yunion i putim Praim Minista long wanpela draipela sia tru na karim em long balus i go insait long ples balus.

Na ol viles pipel i wel kam long em wantaim ol bilas bilong tumbuna em ol i putim na wet i stap long ples balus. Na SDA misin grup i bin putim kwaia singsing bilong ol tu. Na ol bikman bilong Provinsal Gavman na Not Solomons Dipatman bilong sambai tasol i stap insait long dispela bikipela lain pipel i amamasim Praim Minista taim em kamap long ples balus.

Bihain long kabinet kibung Praim Minista bai lukluk raun long sampela hap bilong Provins na em bai i kam bek long Mosbi long Sande, 29, Epril.

Kabineti save kibung olgeta 2 wik insait long olgeta mun. Na tupela wik i go pinis ol i bin kibung long Lae, Morobe Provins. Nesene Eksekutiv Kaunsil i save traim kibung long olgeta senta insait long dispela 4-pela rijon bilong kantri.



● Ol lain eksevisman i tingim dispela de em planti bilong ol i bin dai long namba tu wol woa. Gavana Jeneral, Sir Kingsford Dibela i bin bung wantaim ol lain ex-sevisman long Mosbi RSL.

## Tingim ANZAC De

**LONG Trinde, Epril 25, ol sevisman bilong PNG na ovasis kantri yet husat i bin i stap long Namba Tu Wol Woa i tingim na amamasim dispela de long Mosbi.**

Long bikmoning ol i

bin mekim lotu long Bomana Woa Matmat we ol i planim planti manmeri husat i dai long dispela pait. Lotu i stap long 5 klok long bikmoning yet. Long olgeta senta i gat RSL i stap long em dispela i bin kamap tu.

Bihain ol Ami na Eafos i bin putim ring i gat planti plaua long em long Memorial Ston insait long RSL Klap long Ela Bis.

ANZAC i sanap long makim Australia, Nu Silan Am Ko. Em ol soldia bilong tupela kantri i bung wantaim na pait wantaim ol biru along Namba Tu Wol Woa.

PNG tu i save makim dispela de bipo tasol bihain long kantri i kisim Independens gavman i senisim na putim "Remembrens De." Planti PNG manmeri tu i bin i stap long pait na helpim Australia na Nu Silan

Ami soldia na ol tu i bin dai long taim bilong pait.

Presiden bilong RSL klap long Ela Bis, Mista Ben Moide i putim dispela de olsem i taim bilong tingim bipo ol dispela gutpela pren long ol de mipela i stap long pait. Tasol moa gutpela long mipela ol dispela laki manmeri i bung wantaim gen nau.

Em i tok, "Tasol mipela i gat bikipela rispek na tingim yet insait tru long lewa bilong mipela ol dispela pipel husat i bin givim laip bilong ol long kantri na long mipela nau i stap yet."

Moa long 200 sevisman meri bilong PNG na ol arapela kantri i bin i stap long moning lotu. Na Gavana Jeneral, Sir Kingsford Dibela i bin putim plaua long Memorial Ston long Bomana. Na Hai Komisina bilong Australia, Mista Robert Birch, i bin givim toktok long ol dispela pipel i stap long lotu.

## Plis Ripot

LONG Fonde, Epril 19, wanpela man i bin kilim indai meri bilong em yet. Tupela manmeri bilong Dom viles long Kupiano Distrik, Sentral Provins.

Tupela i bin pait kros na man i bel hat na katim meri bilong em long lep sait bilong nek bilong meri. Na meri i lusim bikipela blut tru na indai long dispela taim yet.

Long Moroma viles long Kerowagi, Simbu Provins, ol lain bilong Mukawku Gentrakani wanpisin na Dambakeni wanpisin i bin pait long Epril 19.

Samting olsem 100 man bilong tupela lain wanpisin wantaim i bin i stap insait long dispela pait. Na 2-pela man tasol i bin kisim bagarap.

Wanpela i kisim spia long sait long as bilong em na arapela i kisim spia long bros bilong em. Tasol no gat man indai long dispela pait.

Pait i bin kamap long taim ol lain bilong tupela wanpisin i bin dring spak na stat long slekim han i go kam. Em i kisim planti ol arapela lain was pisin manmeri i go insait long pait.

Plis Inspekta long Kerowagi, Inspekta Iramu i singautim dispela tupela wanpisin na toktok isi olsem ol i mas bek bek dinau long pasin bilong kompenseen na kamap gutpela pren gen.

# Saten Hailans Laik Dinau

**SATEN Hailan Provins Gavman i tingting long kisim K23.5 milion dinau mani i kam long Wol Beng long kamapim moa wok developman insait long provins.**

Primia Mista Tegi Ebeial i tok aut long Trinde, olsem gavman bilong em bai givim ol pepa i go long Nesanel Gavman long tok save long em olsem bai em i askim Wol Beng long mun Jun long neks yia long gavman bilong em i ken kisim K23.5 milion dinau mani.

Pauline Laki

Long 1978 Saten Hailans i bin kisim wankain mak em K23.5 milion dinau mani i kam long Wol Beng. Na Primia Ebeial i tok ol i kisim dispela mak bilong mani bipo tasol nau ating bai ol i kisim mani i daunbilo long dispela mak.

Mista Ebeial i tok long dispela nupela dinau mani gavman bilong em i laik kisim long Wol Beng bai i kamap moa helt sevis, skul na kamapim rot i go olsem long Pimaga na Lake Kopiago eria.

Em i tok, aninit long baset bilong dinau mani em bilong Provins i plaim pinis long em bai gavman bilong em i wokim 17 helt

sent, 4-pela haikul ol liklik rot i go long 6-pela viles i stap long sait bilong Lek Kopiago, na Pimaga eria.

Nau i no gat rot bilong ka tasol i gat ol liklik han rot tasol bilong ol pipel i wokbaut i stap.

Ol i makim tupela haikul long Provins, em long Pimaga, Magrima, na narapela long Lek Kopiago. Na narapela long Mendi taun yet we nau i gat wanpela haikul tasol.

Mista Ebeial i tok Provins bilong em i wanpela las Provins tru. Na developmen i wok long kamap las tru olgeta taim.

Em i tok, "Mipela i no redi long kisim independens bilong wok mani. Kantri i kisim politikal independens tasol na provins bilong mi i no redi tru long dispela taim na no gat developman i bin kamap."

Em i tok ol bikipela projek long kamapim liklik standet bilong Provins i bin kamap long dispela K23.5 milion em ol i bin kisim long 1978. Olsem na Primia Ebeial i laik traim gen long kisim



Tegi Ebeial

narapela milion kina.

Mista Ebeial i tok Provins bilong em i wanpela las Provins tru. Na developmen i wok long kamap las tru olgeta taim.

Em i tok, "Mipela i no

redi long kisim independens bilong wok mani. Kantri i kisim politikal independens tasol na provins bilong mi i no redi tru long dispela taim na no gat developmen ii bin kamap."

## Momis No Amamas

**NESENEL Eksekutiv Kaunsil, em Praim Minista, Mista Somare sian long en i bin kibung long Kieta long Not Solomons long Trinde, Epril 25.**

Na rijinal memba bilong Not Solomons, Pater John Momis i no amamas long kabinet i kibung long Provins bilong em klostu long taim bilong provinsal ileksen.

Pater Momis i lukim dispela kibung olsem

Pangu i laik go winim sapot bilong em ol pipel bilong Not Solomons.

Not Solomons Provinsal ileksen bai stat long Me 10, Pater Momis i tok ol pipel tu i tingting planti nau na askim nabaut olsem bilong wanem na klostu long ileksen i laik stat na kabinet i kibung long Kieta. Pangu Pati i laik kisim sapot bilong ol pipel.

Pater Momis i bel hevi tru long lukim gavman i kisim Plis Skwat-21 long was long ol Minista na hetman bilong ol Dipatmen husat bia go stap long dispela kibung.



**FORD NEW SERIES 10 TRACTORS BUILT TO BE RELIED ON**

**BOROKO MOTORS**

**Mipela tasol i saplai long dispela nupela lain trakta i go long olgeta hap bilong PNG. I gat trakta bilong 12 hospawa i go inap long 150 hospawa.**



**KIBUNG O KEMPEIN**

I gat 4-pela provins nau long kantri husat i wok long redi nau long provinsal ileksen.

Na long kain taim olsem i kamap bai planti mauswara bilong ol politikman i kamap. Sampela i kamap long ples klia na mekim nabaut long kempein wok bilong ol. Tasol ol sampela i hait bihain long wok tru bilong ol na kempein nabaut.

Long dispela wik yumi lukim kabinet i go kibung long Kieta Not Solomon Provins. I gat planti toktok i kamap nau long dispela long wanem klostu taim bilong provinsal ileksen i kamap. Na planti pipel i lukim olsem gavman bai kempein long ol kendidet bilong en insait long provins.

Klostu long taim Morobe Provinsal ileksen i kamap kabinet i bin go kibung long Lae na wankain toktok i kamap. i tru olsem gavman i save traime long go holim ol kibung bilong en ausait long Mosbi we ol pipel bilong ol provins i ken lukim.

Tasol nau planti bilong yumi askim, bai ol membasing kabinet i go kibung tasol o bai ol i kempein long ol kendidet bilong ol insait long Provinsal Ileksen.

**WANTOK NIUSPEPA**

Nius i kamap 52 taim long yia.

Opis bilong Edita na edvetaising long PNG

P.O. Box 1982, Boroko  
Telepon: 252500 Teleks: NE 22213  
Edvetaising - Ph: 252500

**PE BILONG WANPELA YIA, 52 NIUSPEPA**

Ples	Air	Surface
Port Moresby	K20	K20
PNG	K29	K29
Australia & Sol Islan	K60	K39
New Zealand & Pacific	K78	K46
America & Europe	K118	K60

Printed and published by Kowan Sidney Gallick, of Winter street iranville, at Allotment 2, Section 209, Hohola.

**Tret Yunion Bilong Flai**

**PAPUA Niugini bai i gat wanpela tupela tret yunion em bai i senisim narapela em i wok ong wok nau.**

Olgeta wokman bilong Air Niugini na upela liklik balus kampani, Taliar na Douglas Airways i laik wong wantaim nau na tirapim wanpela strongpela yunion tasol bilong karim hevi bilong ol.

As tingting bilong ispela bung wantaim em lsem ol wokman bilong upela liklik balus kampani i no save kisim wankain pe na sindaun m Air Niugini i save ivim i go long ol wokman ilong em.

Na tu komplem bilong l wokman bilong Talair a Douglas Airways i no ave go longwe tumas ikos ol i no gat strongpela yunion bilong ungim na tok pait antaim bos bilong ol. Planti wokman bilong

tupela liklik balus kampani i lusim wok bilong ol long taim ol i traime komplem long pasin kampani i save mekim long ol. Sindaun bilong ol wokman bilong Talair na Douglas Airways i no wankain olsem sindaun bilong wokman bilong Air Niugini.

Ol dispelasamting i bin subim maus man bilong wokman Talair na Douglas long go lukim presiden bilong Nesenel Ealain Employis Asosiesen, Mista David Unagi, long kamapim wanpela strongpela yunion bilong olgeta ol wokman bilong balus.

Ol wokman bilong Air Niugini tasol i gat wanpela strongpela yunion em ol i kolim Nesenel Ealain Employis Federesen, bilong makim ol na toktok wantaim Air Niugini long ol hevi i painim ol wokman.

Industrial registra, Margaret Kila, i tok orait pinis long tingting bilong ol wokman bilong balus

**Ol bekim Indonesia givim PNG**

**BIHAIN long ol trabel i kamap long boda bilong Indonesia na PNG, Foren Afeas Minista, Rabbie Namaliu, i bin go pas long lain bilong PNG gavman long toktok wantaim Dokta Mochtar Kusumaatmadja bilong Indonesia.**

**Ol arapela man husat i bin go wantaim Mista Namaliu, em Foren Afeas seketeri, Paulias Matane, Dokta Ted Wolfers na Mista Vincent Maragau.**

**Minista bilong Foren Afeas na Tred, Mista Rabbie Namaliu na Foren Minista bilong Indonesia, Dokta Mochtar Kusumaatmadja i no bin painim wanpela gutpela ansa long tupela bikpela hevi long kibung bilong tupela long Jakarta, las wik.**

Mista Namaliu wantaim ol lain bilong em i bin kam bek long PNG wantaim strongpela bilip tru olsem dispela tupela jet balus bilong pait i brukim boda long Grin Riva patrol pos long Wes Sepik provins em balus bilong Indonesia.

Mista Namaliu i bringim dispela hevi i go long kibung i bin kamap long Sande, 15 Epril na pinis long 17, Epril. Dokta Mochtar i no bin tokaut olsem em i balus bilong ol. Long wanem pastaim yet ol bos bilong ami bilong Indonesia i bin tokaut tu olsem em i no balus bilong ol. Dispela tupela balus i bin kamap long Grin Riva long 27, Mas.

Long bekim dispela Indonesia i bilip tru olsem gavman bilong PNG i bin rausim Kenel, Sabastian Ismaeil long mekim wok bilong em hia long PNG. Kenel Ismaeil i bin makim Ami bilong Indonesia na wok long opis bilong Indonesia long Mosbi.

Tasol PNG gavman i no rausim Kenel Ismaeil i go bek long Indonesia. Gavman i bin askim Indonesia long tokaut sapos dispela tupela jet balus bilong pait i bilong ol noogat. Na Kenel Ismaeil, em man husat inap long givim ol kain tok save long ol wok em Ami bilong Indonesia i mekim long boda i no bin mekim wok bilong em. Em i pasim maus i stap olgeta taim gavman bilong PNG i wok long trai hat long painim aut.

Dispela i mekim na PNG gavman i askim Indonesia long makim narapela man long kisim ples bilong Kenel Ismaeil. Tasol Indonesia i no bilip long ol dispela

toktok. Long wanem taim Kenel Ismaeil i go kamap long Jakarta, em i tokim ol niusman long ples balus na ol bos bilong em long gavman olsem PNG gavman i rausim em. Indonesia i bilip long dispela toktok bilong Kenel Ismaeil.

Mista Namaliu i bin tokaut long ol niusman long Mosbi las wik, Fonde, 19 Epril, olsem dispela tupela bikpela toktok i stap olsem yet. Indonesia i bilip yet olsem PNG i rausim Kenel Ismaeil.

Na PNG gavman i gat strongpela bilip tru olsem tupela jet balus bilong pait i kamap long Grin Riva, long 27 Epril, i bilong Indonesia.

Mista Namaliu i bin bringim hevi bilong ol refuji nau i stap long han bilong PNG gavman i go long Dokta Mochtar. Long wanem i gat moa long 1,200 Wes Irian refuji nau i stap long hap bilong PNG long boda.

Mista Namaliu i bin tokim ol niusman olsem ol pipel bilong Wes Irian i ranawe long wanem ol i pret. Tasol Indonesia i no bin tokim stret Mista Namaliu na lain bilong em olsem i gat pait i bin kamap na i wok long kamap yet namel long ol soldia bilong Indonesia na ol OPM rebel paitman.

Ol dispela pipel i tok ol i ranawe i kam long dispela birua i wok long kamap namel long OPM na ami bilong Indonesia. Na planti long ol dispela refuji em ol meri na pikinini.

Dokta Mochtar i tokim Mista Namaliu olsem Indonesia bai i no inap long givim bikpela mekim save o bagarapim laip bilong ol Wes Irian long taim ol i go bek. Tasol gavman bilong Indonesia bai givim mekim save long husat ol Wes Irian pipel em ol i bin brukim lo bilong Indonesia.

Mista Namaliu i tok ol bikman bilong PNG na Indonesia Foren Afeas Dipatmen bai sindaun na toktok gut long ol rot bilong ol refuji long go bek long ples bilong ol. Long wanem dispela taim i gat planti samting tupela gavman i mas stretim bipo long ol pipel ya i go bek long Indonesia. Planti i no save olsem gavman bilong Indonesia bai kilim ol indai o putim ol i stap long kalabus



Ol lain refuji bilong Wes Irian i kam sua long Vanimo.

longpela taim tru o mekim bikpela kain mekim save i ken bringim pe long boda bilong ol.

Indonesia i no amamas long harim olsem PNG gavman i laik bai Yunaitet Nesens opisa bilong helpim ol refuji i stap insait long toktok bilong stretim rot bilong ol refuji. Dokta Mochtar i tok tupela kantri tasol inap long stretim dispela hevi na no gat ausait kantri o man inap long mekim wanpela samting.

Mista Namaliu i tokaut long Indonesia olsem PNG gavman bai amamas tasol long helpim Indonesia long luk save long ol pasin tumbuna bilong ol Melanesia pipel. Long wanem ol Wes Irian na PNG pipel i wankain skin na wankain kastam.

Dokta Mochtar i tok dispela pasin bilong PNG i soim ol pipel bilong Indonesia i givim sem long Indonesia tu. Long dispela kibung tupela Foren Minita i orait long ol toktok we ol spot tim bilong tupela kantri i ken i go pilai long Indonesia o tim bilong ol i kam pilai wantaim ol tim bilong PNG.

Na long ol toktok long ol pait i kamap long Wes Irian we ol pipel i pret na ranawe i kam long PNG, Indonesia i ting em i hevi i kamap insait long kantri bilong ol na gavman bilong ol yet inap long stretim.

Long dispela kibung wantaim ol niusman, seketeri bilong Foren Afeas, Mista Paulias Matane i tokaut tu olsem dispela pilot bilong kantri Swiselan em ol OPM i bin holim kalabusim na tupela man i makim gavman bilong Swiselan na Bisop bilong Vanimo i bin bung long Ossima Katolik Misin stesin klostu long Vanimo.

Bisop na tupela man bilong Swiselan i bin bungim Presiden James Hyaro na pailot Wyder long dispela stesin na Presiden Nyaro i bin givim Wyder i go long han bilong Bisop na tupela man ya.

Mista Namaliu i tokim ol niusman olsem sampela taim long mun Me bai i gat 2-pela bikpela kibung tru i kamap. Wanpela em Boda Liesen

Komiti na narapela em Boda Komiti Teknikal. Boda Liesen komiti i save mekim ol wok bung long lukautim gut olgeta kain wok i kamap long boda.

Na Teknikal Komiti em ol bikman bilong Plis na Ami i stap insait long en. Dispela tupela komiti i gat ol lain bilong Indonesia na PNG i stap insait long en. Na narapela bikpela komiti tru em i Joint Boda Komiti.

Dispela komiti yet i bin sainim tok orait long wok bung wantaim long yia 1979. Sampela taim long dispela yia bai dispela komiti i kibung gen. Na Mista Namaliu na Dokta Mochtar bai sindaun gen long stretim moa toktok na putim nupela tok orait i go insait na rausim olpela tok orait ol bin mekim 7-pela yia i go pinis.

Olgeta dispela kibung bilong 3-pela komiti bai kamap long Mosbi. Mista Namaliu i tok i gat planti asua nabaut i bin kamap insait long ol dispela 7 yia i go pinis. Na bai em wantaim Mochtar i sindaun glasim gut gen dispela tok orait long wok bung wantaim. Na bai i gat planti tenis na nupela tok orait i kamap long dispela taim.

Wanpela samting em PNG bai bringim kamap long dispela kibung em tupela kantri i mas tok save long arapela sapos Ami bilong tupela kantri i laik mekim sampela bikpela asasait long ol eria klostu long boda mak. Na PNG bai toktok strong tru i go long Indonesia olsem Indonesia i mas tok save sapos Ami bilong em i mekim wanem kain operesen klostu long boda.

Mista Namaliu i tok Dokta Mochtar i no tok save long em long wanem taim tru bai Indonesia i salim narapela man bilong Ami i kam long Mosbi long kisim ples bilong Kenel Sebastian Ismaeil.

Mista Namaliu i tok gavman i no gat mani long salim Kenel Kuaga Guria go makim PNG Difens Fos long Jarkata. Kenel Guria i save wok nau long Foren Afeas opis long Waigani.

Mista Namaliu bai givim ripot bilong em

long dispela kibung long Jakarta long kabinet long Trinde, 24, Epril. Kabinet bai kibung long Arawa long dispela wik.

Nau long dispela taim Wes Sepik Provinsal Gavman bai askim Nesenel Gavman, long Dokta Mochtar i go lukluk raun long Blak Wara kem bilong ol Wes Irian Refujis long taim i em i kam long Mosbi long dispela Join Boda komiti kibung long mun Me.

Provinsal Seketeri bilong Wes Sepik, Mista Melchior Kapaich i bin tokaut las wik olsem bai ol i askim gavman long wanem i gutpela sapos Dokta Mochtar yet i go lukluk long ol Wes Irian pipel i stap long refuji kem. Na bai ol yet i ken tokim em long wanem samting i kamap long Jayapura, i bin mekim pretim ol na ol i ranawe i kam long PNG.

Olsem ol Wes Irian pipel i ranawe bikos i bin gat pait i kamap namel long ol OPM na ol soldia bilong Indonesia long Jayapura.

Dispela ol pipel i ranawe na i kam long PNG long stat bilong mun Februari yet. Na sapos Dokta Mochtar yet i go long kem bai em i harim stori long maus bilong ol pipel.

PNG gavman i luksave long ol pipel i stap long Blak Wara kem tasol olsem ol refuji tru. Tasol gavman i no luksave long ol arapela i stap nabaut long ol arapela boda stesin na vilés na long Kembaratoro misin stesin.

Katolik Bisop bilong Vanimo Bisop John Etheridge i go pas long givim kaikai, klos na marasin long helpim ol dispela pipel husat i stap nabaut. Bisop long Vanimo i tokaut las wik olsem Katolik Misin i save yusim moa long K1,000 olgeta wik long helpim ol dispela pipel.

Mista Namaliu i tok olsem gavman bilong em i askim pinis Yunaitet Nesen Hai Komisn bilong refuji i stap long Mosbi long helpim ol dispela pipel. Man i makim UNHCF, Mista Michael Shergold i wok klostu wantaim gavman long helpim ol dispela Wes Irian pipel.



# Provinsal Gavman Ileksen



MARA:

**NARAPELA** provins tu i redi nau long holim ileksen bilong en. Pepa bilong statim ileksen bilong Westen Hailans Provinsal Asembli i bin go aut long Fraide Epril 20; long taim bilong ista holde stret.

Long Tunde moning planti man husat i laik kamap memba bilong Westen Hailans Provinsal Asembli bihain long ileksen, i bin go kamap long ilektoral opis long Maun Hagen na baim fi bilong sanap log ileksen.

Na ol man insait long ol ples kanaka em ol i stap longwe long Hagen bai go long ol aut stesin long hap bilong ol givim nem. Ilektoral opis long Maun Hagen i tok ilektoral komisen i gat wanpela ritening opisa i stap pinis long wan wan aut stesin bilong kisim nem bilong husat man i laik traime ileksen.

Na i no gat planti nois i kamap yet namel long ol bikpela pati olsem i bin kamap long Morobe Provins long las wik. Tasol Pangu pati bai gat wanpela bikpela grup insait long ileksen. Na nesnel pati bai i traime long rausim Pangu long gavman bilong Westen Hailans.

Namba tu primia bilong Westen Hailans, Mista Simon Koiam, i tokim Wantok olsem em i save bai no gat bikpela tok kros i kamap namel long ol pati husat i laik traime ileksen. Gavman bilong em i tingting long mekim gutpela kempin na em i bilip ol lain oposisen i laik mekim wankain pasin.

Pangu pati, Yunaited pati na sampela indepeden i bung nau long ranim gavman bilong Westen Hailans. Na Mista Koiam i tok, "Gavman bilong Westen Hailans i gat gutpela sans tru long winim ileksen na stap yet long gavman."

Tasol Mista Koiam i tok resis bilong winim laik bilong asembli na kamap primia bai i hat. Mista Koiam i tok, "Plantu bikpela bisnis an na plantu save man bai i sanap long ileksen bilong provins na ol dispela man i tingting pinis long traime winim wok primia."

Ol pati i gat nem long Westen Hailans em Pangu na Nesnel Pati. Na Yunaited Pati tu em i wanpela nem em plantu lapun bilong Westen Hailans inap tingim yet. Tasol Yunaited pati na Melanesian Alaiens pati bai no inap kamap strong olsem ol indepeden kendidet. Mista Koiam i tok ol lain indepeden grup bilong em bai mekim gut long dispela ileksen.

Long 3 klok long namba wan de bilong nominesen 6 - pela man i bin kamap pinis long ilektoral komisen opis long Maun Hagen. Na oli ting plantu moa nem bai kapsait i go insait long ol de i kam bihain. Nominesen bai i pinis long Me 27.

Ol pipel bilong Westen Hailans bai stat long vot long Sarere Jun 2 na pinis long namba 23 de. Ol pipel bilong Westen Hailans bai inap save long husat lain bai kamapim gavman bilong ol pastaim long Julai 3.

Long Morobe Provins 176 man i putim pinis nem bilong ol long traime 35 konstituensu bilong Morobe provins. Ol ritening opisa i ting bai plantu moa man i putim nem pastaim long nominesen i pas long Fraide Epril 27.

## Baim Kopi - Husat / Bosim?

**TUPELA** wik i go pinis namba tu lida bilong Oposisen, Pater John Momis, i bin tok olsem long taim em i raun i go long Hailans em i lukim bikpela asua i kamap long pasin bilong baim kopi.



Momis

**WANEM** gavman dipatmen tru i mas bosim wok bilong baim kopi insait long Papua Niugini?

**Dispela em kain askim i kamap nau bikos long nau yet plantu man i save ting wok bilong baim kopi em i wok bilong Dipatmen bilong Industrial Dvelopmen. Dispela dipatmen i tok "Nogat em i no wok bilong mipela. Kopi em i samting bilong ol didiman."**

### Ismael Marabui

Pater Momis i tok, "Ol man bilong baim kopi i save yusim olpela skel em ol yet inap senisim nabaut. Long dispela we ol man bilong baim kopi i ken trikim ol pipel na baim kopi long liklik mani tasol."

Pater Momis i tok, sampela man bilong baim kopi i wok long sakim tok bilong gavman long yusim ol skel em gavman i laik bai olgeta man bilong baim kopi i mas wok long en. Ol dispela man bilong baim kopi i wok long go het long yusim ol skel em ol yet inap tanim nabaut long laik bilong ol.

Long dispela we ol yet inap senisim skel i go na pe bilong kopi tru i save

stap. Tasol ol man bilong baim kopi i save baim kopi aninit tru long stretpela pe bilong kopi. Na tarangu ol pipel bilong salim kopi i bagarap o i gat sampela pipia i stap wantaim kopi bai ol man bilong baim kopi i no inap lusim mani nating.

Pater Momis i tok dispela kain pasin i save kamap stret long ai bilong ol opisa bilong dipatmen bilong Industrial Dvelopmen. Olsem na em i bin singaut long minista bilong Industrial Dvelopmen, Mista Karl Stack long toktok gut wantaim ol opisa bilong em long stretim kwik dispela hevi.

Pater Momis i bin go het long autim bikpela pret bilong em long taim em i tok, "Husat i save? Nogut dispela pasin i no kamap long kopi tasol.

Ating kain giaman pasin olsem i stap tu long ol man i save baim kopra na kakao.

Long dispela wik, Kopi Industri Bot long Goroka i bin kibung na toktok long ol hevi em Pater Momis i bin autim. Siaman bilong Bod long Goroka Mista Ricky Mitis i tok bihain long miting olsem ol i salim pinis sampela man bilong bihainim haiwe long lukim sapos kain pasin olsem i wok long kamap tru.

Taim ol lain bilong sekap long ol man i baim kopi i kam bek long Goroka long pinis bilong dispela wik, bai Kopi Industri Bot i ken autim wanpela toktok long dispela hevi.

Mista Mitio i tok ol lain bilong em i save larim ol man i baim kopi long

tekewe hevi bilong beg o dram long taim ol i skelim kopi. Na em i tok Kopi Industri Bot i laik bai ol pipel i mas yusim nupela skel em i save gat ol namba i bihainim metrik sistem.

Mista Mitio i tok wok bilong kisim skel na salim long ol man bilong baim kopi em Dipatmen bilong Komes i save mekim bipo. Tasol Dipatmen bilong Industri Dvelopmen i kisim pinis dispela wok em Dipatmen bilong Komes i save mekim bipo.

Tasol ekting seketeri bilong Industrial Dvelopmen, Mista Neil Mohanty, i tok kopi em i samting bilong didiman. Wok bilong dipatmen bilong em, em long wari long ol samting i kamaut long ol faktori. Na wanem samting i gro long graun em wok bilong didiman.

Mista Mohanty i tok, "Mipela tu i nogat opisa i wok ausait long ol wan wan provins. Dispela dipatmen i kirap nau tasol na mipela i wok long lukluk yet long olsem wanem bai mipela ken skelim dispela wok i go aut long wan wan provins. Tasol long nau yet olgeta wok man bilong mipel ai save stap tasol long Mosbi."

Tasol Mista Paddy Anis, wanpela strongpela Melanesian Alaiens sapota i tok long taim kopi i redi pinis long salim, em i lusim pinis han bilong dipatmen bilong didiman. Wok bilong baim kopi em i kamap olsem bisnis pinis. Na sapos dipatmen blong praimer industri i tok em i no wok bilong ol, husat tru bai stretim dispela hevi.

## Wes Nu Briten

**WES** Nu Briten Provins em i papa bilong wel pam insait long Papua Niugini. Na nau ol wel pam blok i no kamapim wel pam tasol. Ol i kamapim pinis Nesnel Pati, insait long Wes Nu Briten.

Taim nominesen bi-

long Wes Nu Briten provinsal ileksen i op long Fonde 26 Epril, Nesnel pati bai putim plantu kendidet. Na ol i tok aut pinis olsem Nesnel pati i bilip ol inap kamapim nupela gavman bilong Wes Nu Briten Provins.

Ol man bilong oganaisim kempin bilong Nesnel pati insait long Wes Nu Briten em ol i stap long ol wel pam blok

long Wes Nu Briten Provins. Na lain bilong Nesnel pati ol i laik autim gavman bilong Pangu em Primia Bernard Vogae i wok long go pas long en.

Wanpela man em i was long politiks long Wes Nu Briten i ting Pangu pati na Nesnel pati bai putim plantu kendidet insait long long dispela ileksen.



### ILEKTORAL KOMISIN BILONG PAPUA NIUGINI PABLIK NOTIS WESTEN HAILANS PROVINSAL GAVMAN ILEKSEN

Tok save i go long olgeta manmeri bilong Westen Hailand Provins olsem pepa bilong namba tu jeneral ileksen bilong Provinsal Gavman i go aut pinis long 20 Epril 1984, long ol Ritening opisa insait long wan wan konstituensu bilong Westen Hailans Provins.

Pepa i tokaut olsem long ol de bilong holim provinsal Gavan Ileksen.

1. Nominesen i op
2. Nominesen pas (11:00am)
3. Vot Stat
4. Vot Pinis
5. Kisim Bek Pepa

20 Epril, 1984  
7 Me, 1984  
2 Jun, 1984  
23 Jun, 1984  
3 July, 1984

Andrew S Trawen  
Ekting Ilektoral Komisina



# Ol Drip Manmeri Mas Go Bek Long Asples

Dia Edita - Mi sapotim pas bilong Paul Jambe na raitim dispela pas. Pas bilong em i bin kamap long Wantok Nius namba 502. Paul i tok ol drip manmeri i mas i go bek long asples o provins bilong ol yet.



• Samana |

Mi man bilong Morobe stret na mi stap long provins bilong mi na sapotim dispela pas bilong Paul.

Tasol Primia bilong mipela, Mista Utula Samana, i no laik putim dispela kain polisi long gavman bilong em. Em i laik olgeta kain pipel i stap long Lae na Morobe Provins. Maski sapos ol i no gat haus o ples bilong sindaun bilong ol yet, tasol i ken drip nabaut i stap a mekim moa namba bilong ol pipel long givim vot long em. Olsem na Mista Samana i no laikim gavman bilong em i salim ol drip manmeri nau i pulap i stap long Lae i go bek long asples bilong ol.

Dispela ol drip manmeri i mekim na mipela ol pipel tru bilong Morobe husat i laik kisim wok tu i save painim hat tru. Morobe Provinsal gavman i mas salim planti bilong ol dispela lain husat i save raun nating i

stap long taun i go bek long ples bilong ol.

Mi laik lukim wanem gavman bai kamap bihain long dispela ileksen. Sapos Samana i aut na narapela gavman ikamap, bai mi amamas tasol i stap long lukim sapos dispela nupela gavman bai putim polisi bilong rausim ol pipel i stap nating i go bek long ples bilong ol.

Samana i no wari sapos ol dispela pipel i votim em i gat gupela haus, gupela sindaun o ol pikinini bilong ol i kisim gupela skul o ol papamama i gat mani bilong baim skul bilong ol pikinini o nogat.

I gat planti lain i stap long ol setelman long Lae i gat dispela bikpela hevi tru Plis, Provinsal gavman i mas salim ol dispela pipel nau i pulap long Lae na i raun nating i go bek long asples bilong ol.

Greg Rombat, Apa-Watut, Morobe Provins.

# Enga ples balus

Dia Edita - Mi laik sapotim brata ya, Yangharry long Wantok Nius namba 511. Yes brata nau mi ful sapot long yu bin autim olgeta wari ilong ol Enga pipel.

Taim mi bin ritim pas bilong yu, mi bin pilim narapela kain stret. Stori bilong yu i go stret olsem. Brata mi wok long ritim pas na leva bilong mi, i go ap na daun, na tu ai wari bilong mi pundaun olsem maunten wara stret.

Yes, brata mipela ol grasrut i save wari tru long ol wantok i stap long ples. Tasol ol bikman olsem ol memba bilong palamen na memba

bilong provinsal gavman i no save sori liklik long pipel na long provins bilong ol. Brata Yangharry i bin tok ol i lusim tingting long Wapenamanda ples balus. Enga Provins em i wanpela provins long wanem poupulesen bilong em i winim planti narapela provins long PNG.

Insait long Enga Provins i gat 7-pela distrik. Ol manmeri bilong Kandep, Laigam, Marmun, Pogerra, na Kompam i save painim hat tru long go kisim balus long Hagen, tasol ol pipel bilong Wabag na Wapenamanda tu i save

painim taim stret.

Olsem wanem long yupela ol provinsal na nesanel memba bilong Enga Provins? Yupela yet i go skul long kamap wanem? Yupela i kisim digri we na yupela kamap memba bilong Palamen?

Sapos yupela yet i skelim tingting bilong yupela na askim yu yet bai yupela i tok, mi bai no inap kamap memba tasol ol pipel i givim digri na mi bos bilong olgeta manmeri bilong Enga Provins.

Mobeta yupela olgeta memba bilong Enga nau i save apim waitpela soks i

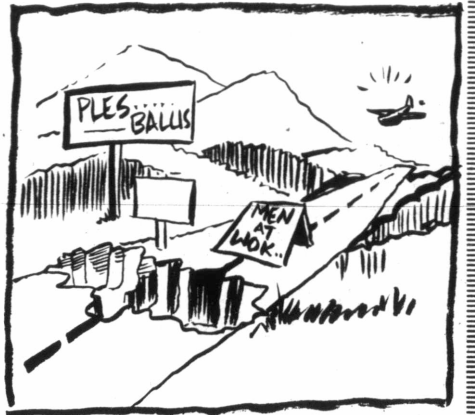

go antap i opim maus na opim ai na wokim sampela kain samting long impruvim Wapenamanda ples balus. Sapos yupela bringim sampela kain projek em bai ol pipel bilong Enga i laikim yupela ol memba moa yet. Na long arapela ileksen bai yupela i painim isi long kisim sit bilong yupela gen. Sapos yu no wokim wanpela kain wok long ples bilong yu wantaim ol, em bai yu lus long sia bilong yu.

Wapenamanda ples balus em mipela ol pipel bilong Enga yet i laik lukim i kamap bikpela, long wanem Wapenamanda ples balus em i rait mak bilong mipela olgeta sab-provins insait long Enga Provins. Planti manmeri i laik go long sampela hap long PNG nau i save lusim bikpela man na westim taim bilong ol na i go kisim balus long Maun Hagen.

Gavman i mas lukluk long dispela na wokim ples balus i go bikpela. Bihain long dispela balus bilong Air Niugini na ol arapela bikpela balus i go daun bai mipela ol pipel bilong Enga i amamas long Nesanel na Provinsal Gavman memba bilong mipela.

Sampela taim mi save harim long redio na niuspepa olsem gavman i save promis nating long planti kain samting bilong mekim wok. Tasol wokim ples balus na wokim rot em i wanpela bikpela samting bilong helpim olgeta pipel bilong PNG.

Plis ol memba bilong Enga yupela olgeta i mas wok wanbel na askim Gavman long wokim Wapenamanda ples balus i go bikpela.

John Kalipso, Boram Korektiv, Wewak, ESP.

## Kisim namba long husat

Dia Edita - Long sampela sios husat man i laik kisim baptais i mas i gat wanpela baptisim ol klas pastaim orait bihain em i ken go baptais. Long sampela taim ol i save go givim nating baptais nating long ol man.

Na tu ol dispela man i no pasto o minista. Nogat, ol man nating i ken givim baptais long ol man husat i laik baptais. Ating ol i laik mekim wankain wok olsem Philip i baptaisim wan-

pela man long raun wara long rot:

Aposel sapta 8.36-40 i toktok long dispela pasin. Tasol ves 35 i tok olsem Philip i bin autim gutnius pastaim na bihain olsem ves 37 i tok, em i askim dispela man sapos em i bilip tru long bel bilong em orait em i ken kisim baptais. Na i luk olsem olgeta man i mas harim gutnius pastaim.

Wanem man bilong givim baptais i mas wok fultaim olsem pasto o minista long wok bilong God. Nogut yu man bilong wok nabaut long sampela man o kampani na long Sande yu givim baptais long ol man na em i no stret. Na tu yu mas i gat tiket long tok save olsem yu man bilong givim baptais.

Buk baibel long Mathew 6.28 i tok, "I no gat wanpela man inap holim wok bilong tupela man wantaim. Bai em i bel nogut long wanpela na i laikim arapela. Bai em i bihainim wanpela na givim baksait long arapela. Yupela i no inap long holim wok bilong mani wantaim."

Dispela kain tok Jisas yet i mekim long maus



bilong em na sapos yu husat man i save mekim olsem mi em i no stret olgeta. Yu mas senis na holim wanpela wok tasol em yu laikim."

Narapela samting tu em mi ting olsem Aposel Philip i bin givim baptais bikos em i bin kisim strong bilong Jisas. Em i save wokabaut na kaikai na kisim skul long Jisas. Em i boi bilong Jisas na Jisas yet em i God. Na Philip yet i no gat narapela wok bilong em.

Holi Spirit yet i bin givim em stret long wanpela wok tasol na em inap givim baptais. Tasol nau ol man husat i laik kamap pastoi i save go long wanpela koles o long seminari na bihain ol i kamap pastoi.

Em tasol long ol tingting bilong mi.

Bikpela Wari, Kainantu.

## Het I Paul Nau

Dia Edita - Mi laik sapotim pas bilong Misis Leonney Raymon. Em i bin tokaut long wari bilong em long Wantok Niuspepa i no longtaim i go pinis.

Misis Leonney, tingting bilong mitupela i wankain tasol. Mi tu mi ting olsem planti manmeri tru nau i save mekim pasin pamuk na pasin bilong stil long dispela kantri. Em i min olsem ol dispela lain manmeri i no sindaun gut long pasin bilong God. Ilukolsem ol i stap ausait tru long misin komyuniti.

Ol dispela kain lain manmeri i raun amamas nating long samting bilong graun tasol. Ol i no save bilip long tok bilong God. Bia i tanim het bilong ol pinis na ol i longlong nabaut.

Yumi save toktok olsem PNG em i kristen kantri. Em i no tru moa nau. Planti kranks pasin i bagarapim pinis nem bilong PNG na i paulim ol pipel long bilip olsem dispela ol pasin i nogut.

Ol memba bilong yumi long nesanel na provinsal gavman yet i soim yumi tu long ol pasin nogut. Planti bilong ol i sanap long kot long kisim grismani o paulim mani bilong gavman.

Planti gupela manmeri bilong PNG i sindaun long pasin misin. Tasol planti kain kain rabis pasin i wok long kamap nau long paulim tingting bilong ol. Dispela em bikpela sem tru bilong PNG.

Ihon Muli, Lumi, WHP.

## Kamapim Moa Dropout Skul

Dia Edita - Mi wanpela manki mi save interes long ritim ol kain nius olsem Pos Kororia na Wantok Nius. Mi sapotim brata Maxon yenda husat i bin raitim pas na toktok long ol pikinini i no gat wok long taim ol i pinisim gret 6,8 na 10 long ol skul bilong yumi insait long PNG.

Pas bilong yu brata Maxon i bin kamap long Wantok Nius namba 511. Yes brata yu tok tru. Ol skul sumatin i save dropout long ol komyuniti skul na haikul na ol i save pinisim nating mani bilong ol papa na mama. I no gat tru wanpela liklik wok bilong ol long ples.

Tru i gat graun long kamapim bisnis, o kamapim egrikalsa, tasol ol sumatin i no gat save long kamapim ol kain wok

olsem. Long wanem taim ol i bin stap long skul ol tisa i bin save skulim ol long Aritmetik, Inglis na ol arapela samting. Na ol i no save long ol samting ol i ken kamapim long ples o wokim gut long papa na mama.

Ol mani bilong papa-

mama i save lus nating. Long bilip bilong mi, PNG bai kamapim sampela skul long lainim ol dropout insait long kantri.

Alex Nixon, STC, Buin, NSP.

## Somau Iwaiwa ples i no gat han rot

Dia Edita - Mi wanpela man husat i gat bikpela sori long ol manmeri bilong bus bilong Madang.

Insait long nambis bilong mipela yet long Madang provins, olgeta hap i gat wan wan han rot bilong ka, tasol long bus, ples i wok long tudak yet. No gat han rot i go long planti hap long bus. Ating bai mipela i stap tudak yet?

Olsem tu na mi laik save wanem samting tru memba bilong mipela,

Tom Muliap (Usini-Bundi) i wok long mekim taim em save go long toktok long palamen. Sapos memba bilong mipela i stap na em i wok long harim mipela yet. Mi laik askim em sapos em inap opim ai bilong em na traim lukluk long ol pipel bilong bus na wari bilong ol.

Mipela ol pipel bilong Somau Iwaiwa stret i laik askim em long kirapim rot i kam long ples bilong mipela. I no gat liklik rot bilong ka i stap long eria bilong mipela.

Sapos yu wanem strongpela man bilong toktok, bai yu ken singaut strong long laik bilong ol pipel bilong yu. Taim Somare gavman i kamap long 1982, mipela ol manmeri bilong Usino-Bundi i makim yu long toktok long ol wari bilong mipela long palamen.

Mi askim nau ol pipel bilong Usino - Bundi long sapotim dispela pas bilong mi.

Kareria Taikuku, Lae, Morobe Provins.

## PNG Painim Problem

Dia Edita - Mi laik autim bikpela problem i stap nau long kantri bilong yumi. Mipela olgeta manmeri long PNG i save pinis olsem PNG na Indonesia i gat wanpela bikpela wari i stap namel long boda bilong ol. Mipela i save tu olsem gavman bilong PNG na gavman bilong Indonesia i no tingting long sindaun gut na toktok long stretim dispela wari.

Namba wan pas bilong mi i bin kamap long Wantok Niuspepa pinis. Mi toktok long tingting bilong Indonesia long tek-ova long PNG. Mipela i save olsem Indonesia i bikpela kantri, bikos i gat planti milion manmeri i stap long graun bilong ol. Klostu olgeta yangpela man long Indonesia i joinim pinis ami bilong ol na ol i redi tasol long bihainim laik bilong gavman bilong ol.

Indonesia i no gat inap graun long ol ailan bilong

ol nau long lukautim olgeta manmeri long kantri bilong ol. Olsem tasol ol i bin kisim hap graun bilong Is Timo pinis. Bihain, ol i putim hap lain bilong ol yet i go sindaun long Is Timo.

Long nau yet, Indonesia i laik kisim Irian Jaya olsem na ol soldia bilong ol i wok long pait wantaim ol OPM. Maski long ol toktok bilong ol opisal bilong PNG na Indonesia long Jakarta, Indonesia i tanim baksait long ol bikpela toktok bilong ol na pait yet egensim ol OPM. Ol OPM em ol hapkas bilong PNG tasol ya.

Pangu Pati i mas painim wanpela rot hariap long pinisim dispela wari. Putim moa mani long ami bilong yumi bai ol i ken kisim samting bilong pait long redi tasol. Sapos no gat bai yumi olgeta i kamap olsem ol haus boi bilong Indonesia.

Wan Tiponda, Hagen, WHP.

moa pas long pes pes 20 na 21



# Madang Singaut Long Stua Takis

DIVISEN bilong Provinsal Afeas aninit long Dipatmen bilong Madang Provins i putim aut pinis wanpela pas long tok save long 16 lokal gavman kaunsil long Provins long nupela kain takis em ol laik mekim.

Benny Bogg

Pas i askim ol lokal gavman kaunsil sapos ol i ting em i gutpela long provinsal gavman i pulim sampela takis mani long ol papa bilong tretstua.

Ol presiden bilong 16 lokal gavman kaunsil long Madang Provins i bin kibung wantaim long Madang Provinsal Gavman Asembli Haus i no long taim i go pinis na ol i toktok long dispela nupela kain takis.

Seketeri bilong Madang Provins, Nallon Derr i tok olsem, "Planti bilong ol dispela presiden i bin tok yesa long nupela tingting long kisim takis long papa bilong ol stua."

Mista Derr i tok olsem, sampela ol bisnis oganaisesen i no hepi long dispela nupela bilong provinsal gavman. Tasol planti ol arapela oganaisesen, bisnis bak stua

provinsal gavman i ting dispela tingting i gutpela.

Mista Derr i tok, "As bilong pulim dispela mani long takis bilong ol papa bilong stua em olsem. Provinsal gavman i laik givim moa mani i go bek long lokal gavman kaunsil. Dispela mani bai helpim ol lokal gavman long ranim gut Rural Improvmen Program (RIP) bilong ol."

Madang Provinsal gavman i no kamapim yet lo long nupela bilong takis yet. Tasol provinsal kabinet lukluk pinis na bilip olsem dispela bilong takis, sapos em i kamap lo nau, bai i bringim bikpela mani olsem K600 tausen long Madang Provins long wan wan yia.

Long dispela K600 tausen o moa, Madang Provinsal gavman i tingting long givim olsem K40 tausen long wan wan bilong ol 16 lokal gavman kaunsil long provins.

Mista Derr i tok, "Madang Provinsal Kabinet i no mekim dispela bil i kamap lo yet, bikos kabinet i ting bai i no long taim Nesenel Gavman bai kamapim wanpela bikpela lo long wankain takis tasol long kantri."

Mista Derr i tok sapos Nesenel Gavman i no kamapim kain lo olsem, bai Madang Provinsal Gavman i ken lukluk gen long dispela bil.

## Wol Beng Lukim Saten Hailans

LONG Tunde, 17 Epril, Vais Presiden bilong Wol Beng, Mista Karasmanoglu, i bin raun long Saten Hailans Provins bilong lukluk long ol projek bilong Wol Beng insait long provins.

Joyce Halu

Mista Karasmanoglu em i namba tu bikpela man tru insait long Wol Beng bilong kam long Papua Niugini. Long 1972 man husat i bin presiden bilong Wol Beng long dispela taim, Mista MacNamara i bin kam tu long Papua Niugini.

Long 1978 Wol Beng i bin tok orait long givim US\$20 milion long helpim kain kain wok developmen insait long Saten Hailans Provins. This projek i karamapim ol kain wok olsem rot, planim ol diwai bilong kisim mani, helt, wok bilong didiman na ol kain samting olsem.

Pastaim long em i kam long Papua Niugini, Vais

presiden i tok olsem as tingting bilong raun bilong em em bilong bungim ol pipel husat i wok long kisim helpim i kam long ol projek em mani bilong Wol Beng i helpim long kirapim.

Taim em i stap long Mendi Mista Karasmanoglu i bin toktok wantaim ol fama husat i gat liklik kopi gaden, na em i lukim wanpela kopi neseri, na em i bin go tu long haus sik long lukim nesesing skul.

Long ples balus long Mendi primia bilong Saten Hailans Provins, Mista Tegi Ebial, i bin givim 5-pela kain basket bilong Saten Hailans i go long Mista Karasmanoglu na meri bilong em.

Mista Ebial i mekim maus bilong Saten Hailans Provinsal Gavman na askim Wol Beng long helpim provins long 5-pela yia plen bilong em em bai stat long 1985.

Vais Presiden bilong wol beng i tok olsem long taim em i makim maus bilong beng em bai wet tasol long lukim askim bilong Saten Hailans Provins long go kamap log lain bilong em.

FRANKFURT - JEMANI - Ol plisman i holim pasim dispela man insait long wanpela protes em ol pipel i bin mekim long Frankfurt ples balus. Samting olsem 10-pela pipel i kisim bagarap na plis i sasim 30 pipel.



# TOYOTA HILUX

## Em bun bilong Papua New Guinea



Hilux i tubuna kar bilong yumi Planti pipol i baim bikos em i strong Na igat planti kain ius bilong en.

Yu ken iusim long karim pasindia wantaim kago. Karim pasindia wantaim kakau, kopra na kopi.

Draivim nupela Hilux

# Nupela HILUX

IKAM LONG TOYOTA

Long yia 1984, Toyota i bringim gen nupela Hilux Nupela ensin em is strong na moa iet. Bun (Sasi) bilong em i strong moa iet.



Ol i penim ananit bai noken ros kwik Stail bilong em i moa iet Sia bilong sidaun i gutpela

Em nau, na Toyota Hilux long 4 x Wil i bun tru Bilong Papua New Guinea.

ELA MOTORS

TOYOTA

WHEELS FOR THE NATION

PORI MORESBY	51 7036	LAE	42 2322
MT HAGEN	52 1888	RABAUL	82 1988
KIETA	95 6083	MADANG	82 2188
WEWAK	86 2255	KIMBE	93 5155
POPONDETTA	29 7240	GOROKA	72 1844
KAVIENG	94 2132	TABUBIL	



A MEMBER OF THE BUNTS PHIP AUTOMOTIVE DIVISION



# Japan Kam Insait Long Bisnis

**OKINAWA** Pis Industri Kampani bilong Japan i gat wanpela mausman bilong em i toktok wantaim PNG Gavman nau long kirapim tupela liklik pis faktori insait long Manus na Kavieng.

Dispela mausman, em Mista Narasaki husat i go pas long wanpela tim bilong Japan i lukluk long rot bilong kirapim pis industri insait long PNG.

Minista bilong Prameri Industri, Mista Dennis Young i tokaut long wanpela kibung wantaim niusman insait long Mosbi olsem Dipatmen bilong em wantaim dispela mausman bilong Okinawa Pis Industri Kampani i wok long toktok nau long stretim ol samting.

Mista Young i tokaut olsem Okinawa Pis Kampani i laik salim sampela bot bilong em i kam painim pis insait long solwara klostu long Manus na Nu Ailan Provins. Na ol dispela bot bilong painim pis bai karim ol PNG plak long en. Ol bai kisim tu ol wokman bilong PNG husat i ken mekim wok bilong painim pis.

Mista Young i tokaut tu olsem wok bilong kirapim tupela liklik faktori insait long Manus na Kavieng bai stat liklik primia bihain. I gat tok save go aut pinis long painim o kampani bilong kirapim dispela tupela faktori.

Ol dispela faktori i no bilong mekim kamap tinpis. Nogat.

Ol dispela faktori bai gat bokis ais bilong putim ol pis. Ol bai katim pis insait long faktori na salim i go long Japan long putim insait long tin.

Dispela wok bai helpim PNG long kisim ol wokman i go wok long bot bilong painim pis na long faktori tu. Na PNG bai gat bikpela bisnis long sensim ol mani bilong dispela pis industri i go i kam wantaim japan na arapela ovasis kantri tu.

Mista Young i no tok a long namba bilong ol ot em Okinawa i laik givim long PNG long painim pis. Em i bin tokaut olsem 4-pela kampani i bin salim eplikesen pinis long kirapim dispela tupela faktori long Manus na Kavieng. Tasol em i no givimaut nem bilong dispela 4-pela kampani.



• Joshua Lukas, trenseta bilong B.T.A., na Robert Conrad, trenseta bilong S.I.L., i wok wantaim long tanim tok long Tok Ples Muhian long Is Sepik Provins.

**DISPELA** yia, 1984, Summer Institute of Linguistics (S.I.L.), wantaim Wycliffe Bible Translators (W.B.T.) bai makim 50 yia em ol i wok pinis long ol Tok Ples na wok bilong tanim tok long Buk Baibel i go long ol Tok Ples em ol i no mekim yet dispela wok long ol insait long

**olgeta hap graun.**

Nupela eksekutiv Vais President bilong dispela tupela oganisesen, Mr. John Bendor-Samuel i tok, "Plantitaim i no gat wanpela samting olsem i kamap long ol dispela komyuniti. Tasol taim bilong ol i kamap pinis. Dispela ol grup o lain i kamapim pinis planti gutpela samting long save bilong yumi long ol tok ples."

Ol i bin holim namba wan trening program long dispela kain wok ol i kolim, "Linguistics" insait long yia 1934 long ples ol kolim Sulphur

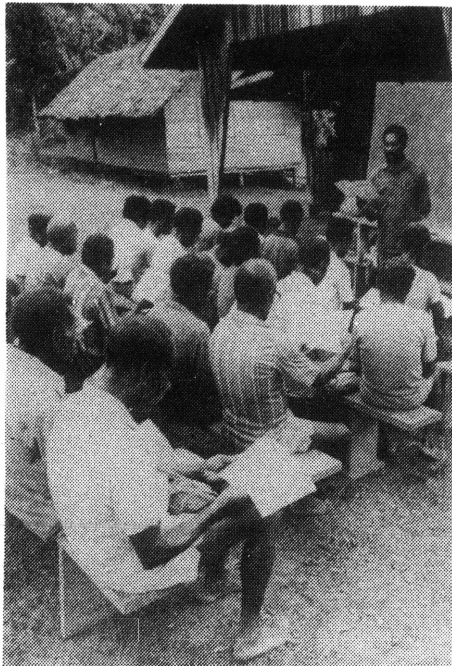

• Joshua Lukas, trenseta bilong B.T.A., i skulim bikpela man long rit na rait long Tok Ples Muhian long Is Sepik Provins.

Springs, Arkansas long Amerika. Na dispela i kirapim dispela wok. Na nau dispela wok i go insait pinis long samting olsem 1,000 Tok Ples long 40 kantri Papua Niugini na sampela arapela kantri bilong Pasifik tu i stap insait long dispela namba.

Dispela oganisesen i kirapim bihainim driman bilong William Cameron Townsend bilong kamapim tok bilong Baibel i go long olgeta Tok Ples em ol i no raitim yet dispela tok bilong ol insait long olgeta hap long graun.

Ol i ting olsem samting olsem 3,000 Tok Ples long dispela 5,000 Tok Ples insait long olgeta hap graun ol i no kisim yet Baibel long Tok Ples bilong ol. Namba bilong ol manmeri em ol i save long ol dispela Tok Ples, ol i ting i moa long 200 milion.

Insait long P.N.G., S.I.L. i statim wok bilong en long yia 1956. S.I.L. na Gavman bilong Papua Niugini i bin mekim wanpela tok orait long S.I.L. bai wok insait long Dipatmen bilong Edukesen.

S.I.L. i save mekim wok long ol Tok Ples, wok bilong lainim o skulim ol manmeri long rit na rait. Komyuniti Developmen na wok bilong tanim tok long Buk Baibel i go long ol Tok Ples na tu S.I.L. i wok bung wantaim ol sios na misin na ol Provinsal Gavman insait long PNG.

Stat long yia 1956, ol wokman bilong S.I.L. i pinisim pinis wok long 40

# 50 Yia Tok Ples Wok

William A. Decker i raitim na William Labu i tanim.

Nu Testamen. Sampela wok long ol Tok Ples na wok bilong tanim tok long Buk Baibel na ol arapela buk nau i stat insait long samting olsem 170 Tok Ples. Na long dispela taim ol i wok yet long 125 Tok Ples.

S.I.L. i bilip olsem bai gat moa wok yet long ol wok bilong ol Tok Ples na wok bilong tanim tok long Baibel na ol arapela kain buk i go long ol Tok Ples, em namba bilong ol i samting olsem 360 insait long PNG.

Harry Weimer, Dai- rekta bilong S.I.L. insait long PNG, i tok, "Mipela, lain bilong S.I.L. i tingim pinis olsem i gutpela tru long wok insait long dispela kantri na kamapim ol Nupela Testamen i go long planti Papua Niugini man long tok ples bilong ol stret.

"Long taim mipela i statim wok mipela i no save olsem dispela wok em i bikpela. Na tu olsem i gat planti tokples tru long hia, olsem na mipela i amamas olsem mipela inap holim han wantaim susa oganisesen bilong Papua Niugini, em long Papua Niugini Baibel Translesen Asosiesen, long winim dispela bikpela wok."

Papua Niugini Baibel Translesen Asosiesen (B.T.A.) i bin mekim tu tok orait wantaim S.I.L. long mekim wok bilong tanim tok long Buk Baibel. Dispela Asosiesen em bilong Papua Niugini stret na ol wokman bilong en em ol man bilong PNG

yet. Long dispela taim, B.T.A. i gat 29 man bilong tanim tok long Buk Baibel na 4-pela man i save long litrasi o wok bilong skulim ol manmeri long rit na rait em nau ol i wok long 19 Tok Ples. David Gela em i Eksekutiv Dairekta bilong dispela Asosiesen.

Wanpela memba bilong B.T.A., nem bilong em Phaniel Oida, em i namba wan long pinisim wok bilong tanim wok long Buk Baibel i go long tok ples bilong em, Zia insait long Morobe Provins. Ol i givim dispela Buk Baibel i go long ol pipel bilong Zia namba wan taim long Krismas de long yia 1982.

Ol i ting Nupela Testamen long Tok Ples em B.T.A. i wok long ol. Ol i ting bai dedikesen bilong dispela Baibel bai kamap long pinis bilong dispela yia 1984.

Olgeta yia S.I.L. na B.T.A. i save givim trening o skul i go long manmeri bilong PNG em Nesenel Transleta Kos na tu Litras Kos. S.I.L. i save ranim tu sampela skul o kos long Tok Ples.

S.I.L. em wanpela oganisesen tasol em i wok long mekim ol wok long ol Tok Ples nabaut insait long PNG. Ol narapela edukesen oganisesen wantaim Institut bilong PNG stadis, na ol sios na misin i wok tu long helpim ol wok long ol Tok Ples bilong dispela kantri.

Insait long dispela 50 yia S.I.L. i bin wok wantaim gavman na Edu-

kesen Dipatmen long mekim ol wok bilong en. S.I.L. i kamapim leta o alpabet long ol Tok Ples em ol i na raitim ol yet na ol kain kain buk long helpim long skulim ol pipel long ritim na rait. S.I.L. i helpim tu long givim skul long wok bilong Tok Ples o linguistik long planti skul insait long olgeta hap graun. Inap long dispela taim, moa long 20,000 pipel i kisim pinis dispela kain trening.

Na tu stat long 1934, moa long 200 Nupela Testamen nau i kamap long sampela Tok Ples, insait long wol. Em i strongim wok gohet long tanim helt na gutpela kaikai o nutrisen na ol buk bilong wok didiman na ol tumbuna stori na ol narapela kain samting em ol pipel i gat laik long en. S.I.L. i save strongim ol pipel bilong ol dispela Tok Ples long raitim sampela samting tu long Tok Ples bilong ol yet.

Planti handet lokal pipel insait long wol, i helpim tu ol trenseta o ol man bilong tanim tok. Sampela long ol dispela manmeri, ol i wok long lainim tu ol narapela Tok Ples na ol i wok long tanim ol.

Bihain long 50 yia, S.I.L. na Wycliffe Bible Translators bai stap wok yet long raitim ol tok i go long ol Tok Ples long helpim long lukautim ol pasin bilong ol. Na tu bai helpim long sanap strong long luksave long ol pasin bilong ol narapela lain pipel long ol.

## Samana Lusim Opis na wok ausait

**MISTA** Utula Samana i bin lusim pinis opis bilong primia bilong Morobe provins long Tunde na nau em i wok long wok insait long narapela haus em pati bilong em i rentim bilong yusim long taim bilong ileksen.

Na Mista Samana i wok long tunde long muv aut long haus bilong primia long pinis bilong dispela mun. Dispela bai i larim ol kamda long stretim haus na wetim husat nupela primia long go insait long dispela haus bilong gavman.

Opisal ka bilong primia i go bek pinis long pul

bilong transpot dipatmen na draiva i stap nating nau. Mista Samana i wok long raun na mekim wok bilong primia long ka bilong pati bilong, Morobe Independen Grup (MIG).

Olgeta minista insait long gavman bilong nana bai pinis long raun long ka bilong gavman long dispela wik. Na bai ol lusim opis bilong gavman tu pastaim long ol istatim kempin bilong ol.

Stat long nau i go inap long taim nupela gavman bilong Morobe i kamap, Mista Samana bai wok

insait long SAVLOAN BUILDING, em wanpela haus MIG i rentim long ranim ileksen kempin bilong en.

Pasin Mista Samana i mekim em i bihainim tru lo bilong ileksen em olgeta lida i mas bihainim. Long taim ileksen i laik kamap olgeta lida i mas lusim opis bilong gavman na ranim wok kempin ausait i long opis bilong gavman. Ka bilong gavman em i no ka bilong ran nabaut insait long en long taim bilong kempin. Hamas lida bilong yumi i bin mekim dispela pasin long taim bilong kempin?

### KOPI

Gret  
Y - K1.85 inap K2.00  
X - K1.90 inap K2.03  
A - K2.00 inap K2.05  
Robusta - K1.70 - K.72  
Kainantu - K1.23 - K1.25  
Goroka - K1.15 - K1.22  
Kundiawa - K1.28 -  
Minj/Banz - K1.05 -  
K1.32  
Maun Hagen - K1.04 -  
K1.21  
Wapenamanda -  
Lae - Arabic- K1.00 -  
K1.30  
Robusta - 80t  
Wewak Robusta - 75t -  
80t  
Madang Arabic - 80t  
Robusta - 70t

Pe bilong kopra long wik stat long 6 Epril.

Mas USS KINA

26 - 741.50 - 631.74  
27 - 741.50 - 625.32  
28 - 736.50 - 625.37  
29 - 729.00 - 619.16  
30 - 731.00 - 622.13

## Westen Hailans Provinsal Ileksen

**OL** pipel bilong Westen Hailans bai redi nau long namba tu ileksen bilong provinsal gavman.

Man husat i go pas nau long wok bilong ileksen long kantri, Mista Andrew Tarawen i bin givimaut ol pepa bilong statim ol wok ileksen insait long Westen Hailans provins long Fonde 20 Epril.

Mista Trawen i tok olsem nominesen long olgeta sit insait long provins i op long 20 Epril. Na bai pas long 11 klok moning long 7 Me.

Ol pipel bai stat long vint long Sarere 2 Jun na taim bilong vot i pinis long Sarere 23 Jun. Na bihain tasol bai ol i stat long kauntim ol vot bilong ol pipel.

Mista Trawen i tok olsem ol pipel bilong provins bai save long em bilong ol nupela memba bilong ol long 24 Jun. Na olgeta wok bilong Westen Hailans ileksen i pinis long 3 Julai.



# HIA EM INAMBAWAN SWITKAI BILONG PNG CRACKER BISKET WANTAIM ANCHOR SIS

PNG Cracker Bisket feivaret switkai bilong PNG stret, na bai swit moa yet wantaim liklik hap Anchor sis antap long en.

Kain nambawan swit tru bilong Anchor sis i kam long Nu Silan wantaim nupela smel bilong PNG Cracker Bisket i kamap long Morobeen nau em i namba wan switkai bilong olgeta memba insait long famili.

Dispela PNG Cracker Bisket na Anchor Sis i stap insait long ol gutpela stua long olgeta hap bilong PNG nau!



**Anchor**

**PNG  
Cracker**

*Morobeen*  
BISCUITS

SIONI 1 3914



**"EVEN THE WIFE  
COULD DO A 3  
POINT TURN IN  
IT!"**



**With minimum turning  
radius of 4.4m, you can  
get out of those really  
awkward spots easily.**

**At your Nissan Dealer. *I'm ridin' my way!* with **The GOOD GUYS****

BOROKO MOTORS - 25 5255 - Port Moresby  
BOROKO MOTORS - 42 1144 - Lae  
BOROKO MOTORS - 92 2777 - Rabaul  
BOROKO MOTORS - 82 2433 - Madang  
BOROKO MOTORS - 52 1433 - Mt Hagen  
ARAWA MOTORS PTY. LTD. - 95 1566 - Arawa  
HIGATURU MOTORS PTY. LTD. - 29 7175 - Popondetta  
PROVINCIAL AGENCIES PTY. LTD. - 94 2131 - Kavieng  
TORA MOTORS PTY. LTD. - 57 4059 - Wapenamanda  
MILNE BAY ENTERPRISES - 61 1167 - Alotau  
WEWAK DATSUN AND MARINE - 86 2220 - Wewak



**BOROKO MOTORS**

BOROKO MOTORS - 25 5255 - Port Moresby  
BOROKO MOTORS - 42 1144 - Lae  
BOROKO MOTORS - 92 2777 - Rabaul  
BOROKO MOTORS - 82 2433 - Madang  
BOROKO MOTORS - 52 1433 - Mt Hagen  
ARAWA MOTORS PTY. LTD. - 95 1566 - Arawa  
HIGATURU MOTORS PTY. LTD. - 29 7175 - Popondetta  
PROVINCIAL AGENCIES PTY. LTD. - 94 2131 - Kavieng  
TORA MOTORS PTY. LTD. - 57 4059 - Wapenamanda  
MILNE BAY ENTERPRISES - 61 1167 - Alotau  
WEWAK DATSUN AND MARINE - 86 2220 - Wewak





COLLEGE OF EXTERNAL STUDIES

# Going Places

High School at home - COES helps  
you with your studies



COLLEGE OF EXTERNAL STUDIES

**No 95**

## Goroka Provincial Centre

**My name is Thomas Kamtel, and I am the COES Co-ordinator for the Eastern Highlands Province.**

There are about 500 students in the Eastern Highlands. I have visited a large number of these students in Lufa, Okapa, Kainantu, Benabena and Asaro.

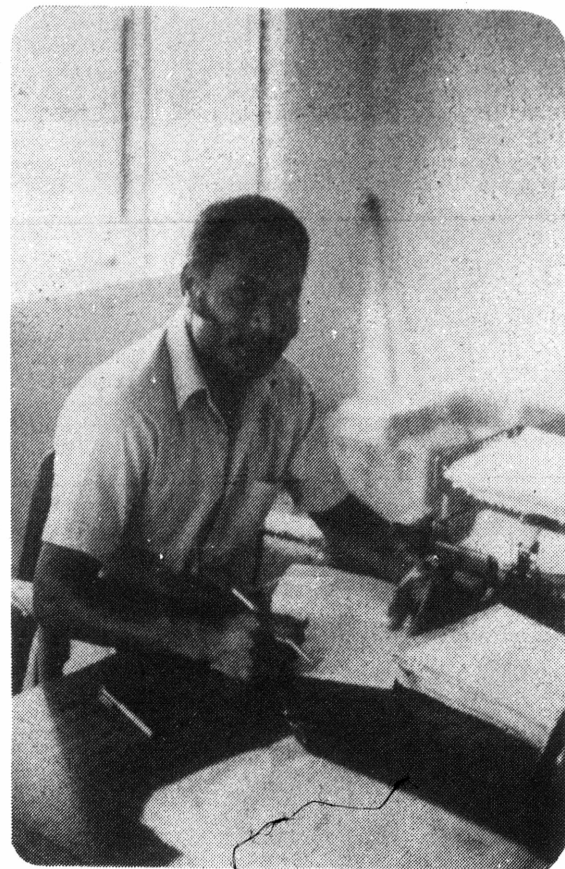

The COES Centre is situated in the Non-Formal Education Office opposite the Raun Raun Theatre. This is a temporary office as a new office for COES will be built near the Public Library.

I like it when students come to my office. They can sit for Entrance Exams or enrol in their next subject. If they have any queries, they can ask me and get the answer straight away.

COES students in the Eastern Highlands should listen to the Education Programme on Radio Goroka at 2.30 on Tuesdays. I often give COES news on this programme. As well, I broadcast messages and other items on Tok Save.



Here are some students waiting to see me at the office.

A Study Centre has been established called the Lutheran Study Centre. There is also a Study Centre at SIL at Ukarumpa. A Study Centre is where a group of students study COES lessons together and have a teacher to help them.

Remember students - come in and see me at my office. Also, listen to Radio Goroka and I'll tell you when I'll be visiting your area.

**Thomas Kamtel,  
P.O. Box 990,  
Goroka,  
Phone 72 2213.**





## OUR NEIGHBOURS Part V: Links with other countries."

This is a 5 part series. This is the last part. The first part was called "Countries on our Borders." Part II was "Our Island Neighbours in the Pacific." Part III was "Our Continental Neighbours in the Pacific." Part IV was "Links with our Pacific Neighbours."

"The Prime Minister, Mr. Michael Somare, on 13th October, '83 addressed the 38th Session of the United Nations General Assembly on Papua New Guinea's approach to its relations with the rest of the world under a much changed foreign policy entitled 'PURPOSEFUL DIRECTION.' He went on to explain, "By this we mean, that without being strident or aggressive, we are pushing for progress toward international equity and order, through bodies like the United Nations, and other international organisations."

Below are just a few examples of the links PNG has with other countries. Papua New Guinea, like many small nations, has great difficulty in keeping up with all the decision making that is the result of the many organisations that operate between the world's nations. Often Papua New Guinea feels

out-manoeuvred by and not as well prepared as larger countries with whom she must deal. Papua New Guinea therefore has to be very careful in the use of its few diplomats. They can attend only those meetings which affect PNG or PNG's beliefs. For many of Papua New Guinea's neighbours in the Pacific, the problem is even greater.

Among the problems facing international order are colonialism, nuclear testing and the arms race, racism, and the Middle East. The problem for international equity or equality is the growing difference between the poor countries and the rich. This is caused by the growing dependence of the developing world on help from the developed world. This includes the increasing dependence of undeveloped countries on countries with technical skills and knowledge of modern technology.

### MIDDLE EAST

Papua New Guinea is very worried about the troubles in the Middle East. The question of a homeland for the Palestinians, the independence of Lebanon and the right of Israel to exist as a country are all issues that could cause conflict. This conflict could grow into a much more dangerous situation, even a World War, at any time.

### THE ARMS RACE

Papua New Guinea is horrified by the fact that the world's governments are spending \$800,000,000,000 per year on weapons. As the Prime Minister has pointed out .... "Such vast spending on arms is not contributing to security - we believe it is contributing to insecurity .... That spending, given the poverty of most of the people of the world, is obscene."

### TRADE

Papua New Guinea is working to establish its economic independence by finding markets for its goods in other places. PNG is keen to join ASEAN countries (Singapore, Indonesia, Thailand, Malaysia, Brunei, Philippines) which supplies PNG with 20% of her imports. PNG has very strong trading links with West Germany and Japan who take 60% of PNG's exports. PNG's traditional trading partner, Australia, supplies PNG with 40% of PNG's imports but takes only 9% of PNG's exports.

### AGGRESSION

Papua New Guinea believes that every nation, small as well as large, has the right to be free from foreign invasion or from foreign interference. Vietnam must withdraw from Kampuchea. Russia should withdraw from Afghanistan.

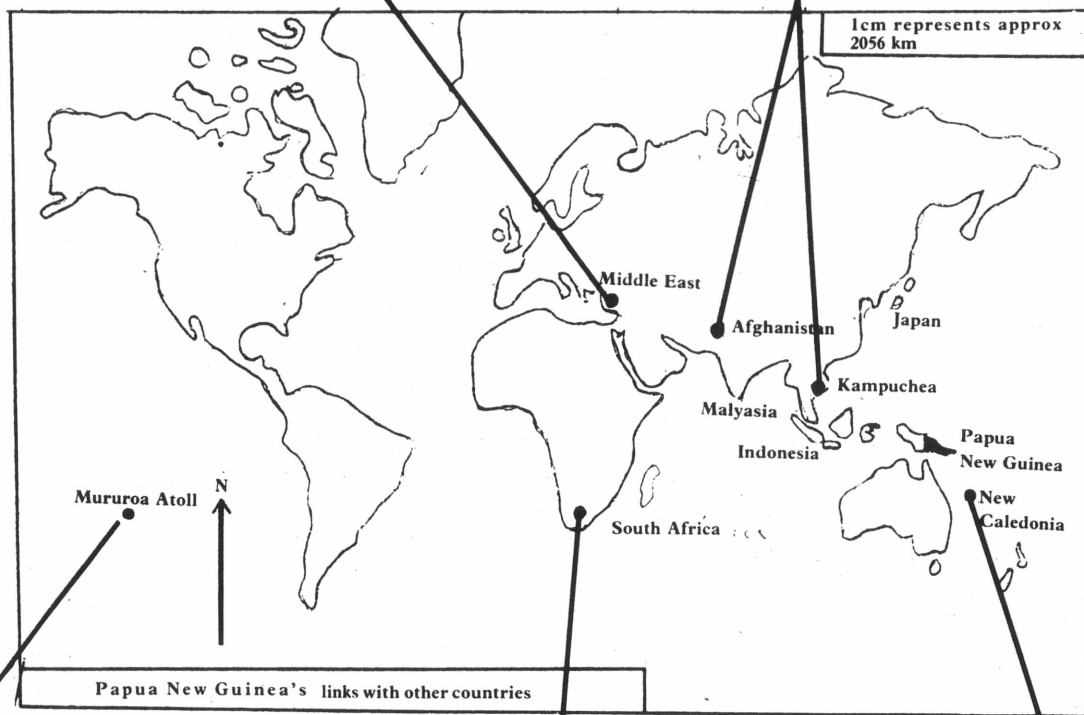

### NUCLEAR TESTING

Papua New Guinea has protested against the French Government's nuclear weapons testing on Mururoa Atoll. Also France has made Papua New Guinea very angry by ignoring the protests of the Governments and the people of the South Pacific. The environment of the South Pacific is being threatened by these tests.

### RACISM

"Racism and apartheid are .... inconsistent with any concept of lasting international order. They offend the principles on which societies like mine are founded. Their practitioners deserve not only condemnation but isolation." The Black Africans in South Africa are victims of apartheid.

### COLONIALISM

Papua New Guinea sees colonialism as the worst type of interference by one country in the affairs of another. Papua New Guinea supports all people who are trying to get rid of colonial interference. This is especially so in the South Pacific where New Caledonia is a colony which still has no set plan for independence. Where there is colonialism there is no equality. As Michael Somare said, "There cannot be long-term order without equality ...."

### COMMONWEALTH OF NATIONS

This is an association of independent nations that used to be part of the British Empire. Some countries like Papua New Guinea have Queen Elizabeth II as their Head of State. Other members of the Commonwealth are republics with an elected President as Head of State. The Commonwealth of Nations operates on the basis of friendly co-operation to overcome a variety of problems. The Commonwealth Fund for Technical Co-operation provides technical advice and help to its members. It also discusses issues like nuclear waste dumping, the move to independence by Zimbabwe and anti-apartheid boycotts. In the words of Mr. Brian Amini, PNG High Commissioner to New Zealand, "... PNG has not regretted the decision (to join) and continues to appreciate the invaluable assistance given to all members of the Commonwealth."

### THE INTERNATIONAL ECONOMIC SYSTEM

Papua New Guinea, like most other countries, has suffered from the economic recession. It has meant that Papua New Guinea, an independent nation, has had to depend even more on aid from overseas countries, especially Australia. Trade agreements like SPARTECA with Australia and New Zealand, do not help Papua New Guinea to modernise its economy. Papua New Guinea needs technical skills and the knowledge of modern technology to become a truly independent nation. Papua New Guinea would like to join Indonesia, Malaysia, Thailand, Singapore and the Philippines in ASEAN (Association of South East Asian Nations) if invited. Then she would have access to the technical knowledge and skills that have kept ASEAN countries among the least affected by the recession.

### THE NON-ALIGNED MOVEMENT

This Movement was begun in 1961 as an alternative to the two super powers, communist Russia and capitalist U.S.A. Today there are 101 members of the Movement from all regions of the world. But today the Movement is very divided. Over the last three years Cuba has been Chairman and has tried to bring the Movement closer to Russia's ideas. Papua New Guinea is an observer at the meetings of the movement because she wants to know what is being discussed. If there is anything that affects Papua New Guinea, then she will be able to get her friends who are members to speak for her. Papua New Guinea does not want to be a member yet because she does not want to get involved in all the conflicts about political ideas. Papua New Guinea is still a young country and is building up her own ideas. Also, there are many organisations and groups of countries in the world. Papua New Guinea, as a small nation, does not have the resources to attend them all.



# Wantok Rugby League Pullout

## Brothers Cool Win

**EASTS Club members will always be pleased to boast about the day they came from nowhere, when the fight was on for the 1984 Kool Cup and finish second best to Enzed Brothers of Port Moresby.**

Benny Bogg

And this was the first time ever, Brothers in Port Moresby entered the Kool Cup Challenge and come out winners of the competition.

Brothers Coach, Brian Wilson first took Port Moresby Brothers to Lae's Cambridge Cup Challenge in 1979, and there too, they won the title. Brothers have set a history for their club as well as the competition.

How the underdogs - Easts almost set a new record for their club is explained by coach Nelson Passingan as "not so much on my coaching, but team spirit and individual positive mental attitude that we

are the best."

Being the second last of eleven teams in the Moresby "A" grade league Easts played an excellent game when they took on a much more fancied Enzed Brothers, and kept up with Enzed from start to finish.

Commenting on the performance of his boys, Passingan said, "Their spirit was very high on the field, especially during the first stanza." "But", he added, "even though many of my boys performed their very best, we can only do so much. We have come very close to a significant win and I think the best team wins."

Nelson Passingan is a very experienced coach. He has been coaching since 1974, but last Monday, Brothers proved to be a better team than his boys.

East is a Seventh Day Adventist Club, which believes in resting on Saturdays which is one reason why they have remained wooden spooners for a long time in Moresby.

Enzed Brothers thrashed East 28-14 to win the Kool Cup plus the K2,000 award in the finals played at the Lloyd Robson Oval. Their experience to hard tackling and pressure paid off well in front of a crowd of more than 4,000 people.

Brothers Captain, Wera Mori, Francis Biroro and Michael Matmilo were keys to brothers win. Expert ball handling from the Brothers line gave them a lead which East's late trys could not over ride.

Only time stopped the last minute pressure from Easts to turn the tables on Brothers, who were obviously walking in the dying stages of the second stanza.

But Easts themselves looked lost and passed up many chances of clear trys and the game was held to a stalemate for a better half of the game. Brothers must be praised for their specular wing-to-wing ball play towards the end of the match, during which most of the players were winded and tackles were only half-hearted.

Again the best Brothers were, Francis Biroro, Leo Pilakai, Morris, and Michael Matmilo.

For Easts, players like, Daroa Harry, Isaiah Lavari and Toligai displayed some best football their supporters and spectators had not seen for a long time.

While Brothers earned their K2,000, Easts collected K1,500, with a promise to a better season in the 1984 season proper which begins next weekend.

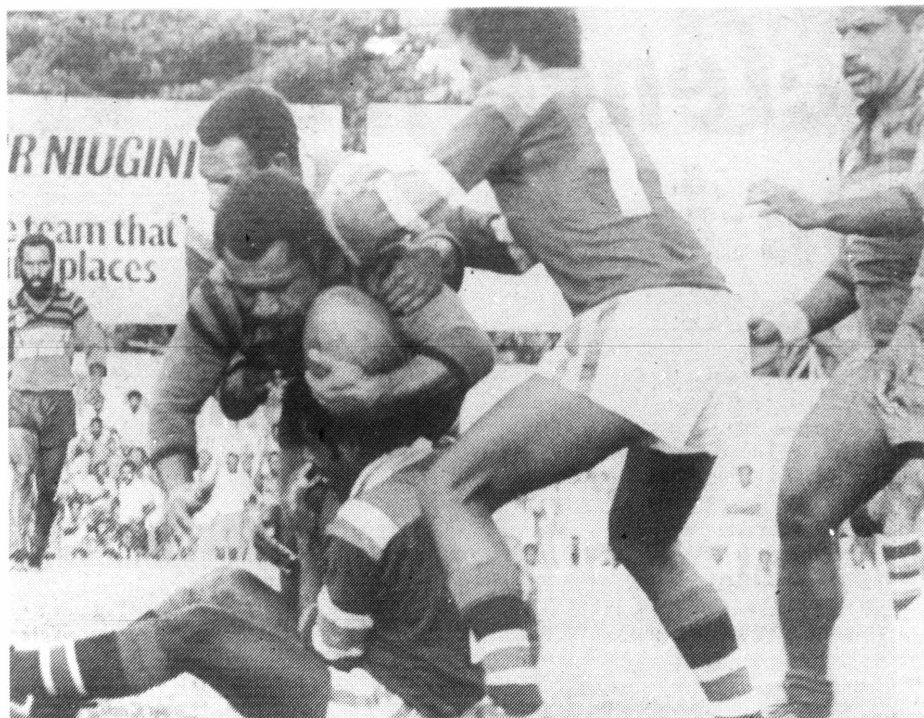

**Sole brethern in a pack of hungry Easts, yet he managed to hold his ground.**



**Again, another brethern goes down in a finished tackle and gets ready to play the ball.**

**Pictures: Markroy Teno**



**Easts collecting their K1,500 prize money for the 2nd place, from Prime Minister, Michael Somare at the Lloyd Robson Oval on Monday.**

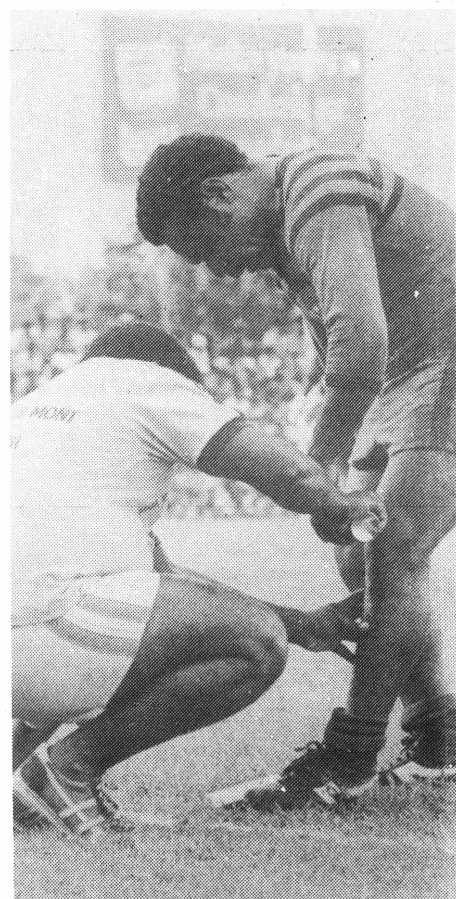

*Giving a helping hand to a Brothers player.*



**Brothers ran out winners of the Kool Cup challenge against Easts, 28 - 14. They also won a K2,000 prize .**



# Wantok Rugby League Pullout

## Defence just made it

**THE Kool Cup Competition for 3rd and 4th place between Defence and Tarangau was full of colour, especially in the second half when Tarangau put up a desperate fight to overwhelm Defence's lead.**

Benny Bogg

Unfortunately for Tarangau, Defence proved a better team by edging them out 36-32.

Defence Club in Port Moresby's Rugby League has a reputation together with DCA for strategic moves to winning battles. Sticking to that reputation, Defence's well planned moves initiated and masterminded by their leader Roy Loitive and compatriot Jerry Wainge secured their 3rd place plus their K1,000 prize when they beat Tarangau at Lloyd Robson Oval last Monday.

On second thoughts, the third place and prize of the competition should have gone to Tarangau. But straight hard runnings displayed by Tarangau on Easter Friday,

Saturday, and Sunday, was punishment enough. Monday was their worst day, yet that should not have been their excuse for losing. The other teams did go through the same kind of hardships.

Defence opened up the score 5 minutes into first half as Andrew Gandhi scored at a far side of the field. Alex Togola's left foot failed to secure the conversion and Defence lead 4-0.

Now and again, Defence bombarded Tarangau's defences and scored at the interval of 5 minutes.

Despite tactical tackles by Defence, Tarangau's big Daroa Benmoide scored two corner tries for his team to trail Defence 8-16 in the first half. Tarangau's greatest set back was through their ball handling, which is vital in any match.

Tarangau returned to the field to find themselves facing a more determined Defence side. But they were just as determined to tackle harder and brush up on their ball handling.

Again the first try for that half was scored by Defence. Skipper Roy Loitive broke

through Tarangau's strong defence before feeding winger Jerry Wainge who went on to touch down inside Tarangau's tryline.

Daroa Benmoide and his Tarangau boys retaliated with the same power and dominated most of the second half. For a good 20 minutes, Tarangau fought hard and scored two tries, but were too far out at the corners, which made it impossible to score conversions. Tarangau collected on conversion points and still trailed Defence 16-22.

As Defence tried to outrun and defeat Tarangau, they scored another three tries. Even though Tarangau held up the hard runs throughout the entire second half they could only manage to score three tries of which only two were converted.

Defence tried to but could not run away from Tarangau with their tries. The score at full time proved that the fight was hard and could have been anybody's game, as Defence barely had enough to boast about their win. Tarangau took the 4th placing as Defence walked off with K1,000 prize with a score of 36-32.



**A spectacular run by Defence's halfback to score a try. However they did not run away from Tarangau with their tries, 36 - 32**



**An up - down under finished tackle by Brothers to an East player during the grand final battle.**

## Tarakum No Match For Tigers

**MINOGERE Tarakum defeated Rongo Tigers 22-27 in the finals of the Eastern Mini Rugby League competition at Goroka, to win the K1,600 prize.**

By Side Liner

From the kick-off, with skipper Linus Geni at the helm, Tarakum took play control of Tigers territory before the hard running Toyo Evei paved the way for inside centre Boniface Yombai, to score Tarakum's opening try. This was about twenty minutes after the start of the game.

Conversion attempt by Linus Geni failed. Tigers shaken by the try, retaliated with plenty of hard running in the forward, but still resistance by the Tarakums threw Tigers co-ordinated play into shambles.

Tarakum capitalized on tigers momentary disorganisation to send their big outside centre, Jeffrey Kaputin to score. Linus successfully made the conversion to bring

Tarakum 10 points to nil.

The play in the remaining minutes of the first half was evenly fought out before a swift ball handling in the Tigers back line sent Western Apo to score in a far corner.

Apo failed to make the conversion. Tarakum quickly retaliated with two quick tries from second rower Simion Heni and gain Linus Geni respectively.

Linus converted his try to seal of the score for the first stanza, 22-4 in favour of Tarakum.

The play in the second half was dominated by Tigers as they made a determined come back to save themselves from what could be a humiliating defeat.

Tigers pressed Tarakum in their own turf for the better part of the second half and gave Tarakum no room to manoeuvre.

Former Kumul Captain, John Joseph dictating play in the enemies territory was superb in setting up his forwards to bombard Tarakums defences

before setting his backs up. Joseph's efforts paid off.

After an initial field goal from Francis Matmilo's boots, the hard running big forward Lois Jeffrey barged his way through Tarakum's back line before sending the outside centre Yakabus to score. Western Apo made the conversion to bring Tigers 11-22.

Play then sea-sawed for some 10 minutes before John Joseph brushed aside Tarakum defenders to score in the corner. Apo's golden boots made the conversion to bring the score, 17-22.

The play within the remaining minutes was hard and tough and both sides probed each others defensive line up to score.

And with only a few minutes of play remaining, Tarakum sensing a possible walkover by the swift flowing style of Tigers play, held on firmly to deny the hungry Tigers any more room to score before full time.

Tigers performances, although small with the inclusion of

Kumuls Frazier Giheno and John Kelly, should find some consolation in the runner-up prize of K850.

The full time score was Tarakum 22 Tigers 17.

John Joseph, Francis Matmilo, Alois Jeffery and Yakabus tried hard for Tigers,

While Linus Geni, Koro Farapo, and Tuyo Evei should have shown brightly for Tarakum.

Scrumms favoured Tigers 12-8. While penalties were Tarakum 9 Tigers 3. Earlier, Gouna Hawks trashed Collins and Leahy United 12-4, to pick up the third prize of K550.

The president of Goroka Rugby League, Ricky Matio gave a personal prize of K100 to the Collins and Leahy United for their consistent style of football, and for coming fourth in the competition.

This weekend, season proper will begin with junior grades playing on Saturdays and senior grades on Sundays.



**Tarangau Captain receiving K500 cheque prize for coming 4th in the Easter Kool Cup competition. P.M. Somare handing over the cheque.**



**Defence out to kick the ball after a try scored by Tarangau.**



# Wantok

# WHOLESALE

No.1 April 28, 1984

## And Tradestore Supplier



# A wholesale welcome!

**GUDE na Welkam!** This week Wantok Niuspepa launches Papua New Guinea's first monthly trade paper. It aims to serve the nation's tradestore owners, and wholesalers - and through them, the three million consumers who form the public.

Feel free to write to Box 1982, Boroko, or phone 25 2500 if you have news or views about this, the liveliest PNG-run business sector.

• To celebrate the first edition of Wantok Wholesale and Tradestore Supplier, a small party was held at the Word Publishing press, at Hohola, Port Moresby, to see the first copies being printed.

## Advertisers:

Andersons .....	37
Arrow Bakery .....	39
Boral Gas .....	19,22
Boroko Motors .....	12
Burns Philp.....	15-18
Carpenters .....	32,33
Chin-H-Meen.....	10,11
Coffee Industry Board .....	36
CSM.....	37
Development Bank .....	31
Exmark Stock.....	6
Gordon & Gotch.....	23
Highlands Raised .....	34
Kes Holdings .....	29
Johnsons Pharmacy .....	2
Markham Meats .....	5
Meridien Motors .....	4
Niugini Table Birds .....	38
Pacific Gold Studios.....	35
Paradise Bakery .....	20,21
Rosemary Roy .....	8
Sapphire Smallgoods .....	14
G. Seeto .....	24
Steamships .....	25-28
Web Books .....	30
Woo Enterprises .....	9
Wills .....	40

**ABOVE: Some of the first guests at the launching ceremony.**



# JOHNSTONS

Plantation  
Suppliers  
Industrial,  
First Aid and  
Hospital Supplies

Trade Store &  
Supermarket  
Suppliers  
Mail Orders

# PHARMACIES

PTY. LTD.

## WHOLESALE

## OF ALL

## CHEMISTS

## MERCHANDISE

## AND

## RELATED SUNDRIES

GENERAL ENQUIRIES  
(MR. PAUL) 25 3633

### WHOLESALE & PLANTATION ORDERS

Spring Gardens Road, Gordons

**25 3185 or 25 3633 or 25 3356**

P.O. BOX 1066 BOROKO. PNG

COUNTRY ORDERS C/- BOX 146, PORT MORESBY.

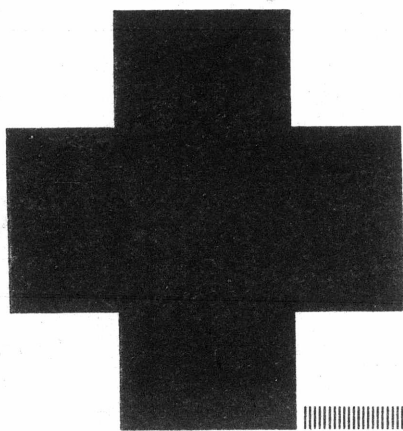

# FIRST AID KITS FOR SALE

★ Homes   ★ Plantations   ★ Schools  
★ Office   ★ Aid Posts   ★ Trade Stores.

**MEET GATU — HE IS OUR MAN AT OUR  
WHOLESALE SALES COUNTER**

Gatu knows all about our stock and can help you  
locate your needs.  
This means you don't have to wait long. If you have  
a large order we will pack and deliver in Port Moresby.



**For trade orders outside of Port Moresby phone Dago on 25 3185 Ext. 24 or  
write c/o P.O. Box 1066, Boroko. N.C.D.**

**We will airfreight or seafreight. Send for our wholesale price list.**

**For indent orders phone: Julie Anne 25 3185 Ext 14**

*Call us at*

**JOHNSTON'S  
PHARMACIES PTY. LTD.**  
P.O. BOX 1066, BOROKO. PAPUA NEW GUINEA

*For a better deal.*

# Wantok Wholesale and Tradestore Supplier

'Supplier' suppliers valuable new customer

Rosemary Roy Pty Ltd

Rojon Pty Ltd

TRADING AS "Rosemary's"

P. O. Box 6983, BOROKO, PAPUA NEW GUINEA.  
HEAD OFFICE PH: 258414

16th April, 1984.

Dear Sir,

Please allow me to congratulate you on the first edition of "Wholesale & Tradestore supply" which was published in December last year.

As a result of this publication our Company was able to obtain one (possibly more) very valuable customer who has since become a regular buyer at our Warehouse.

May I wish you all success with future issues of the publication and assure you of this Company's fullest support.

Yours faithfully,

J. H. ROY.

MANAGING DIRECTOR.

## Wantok takes on a wholesale success

THE pilot edition of *Wholesale and Tradestore Supplier* was such a big success, that Word Publishing Company has now decided to make it a monthly publication, inside the newspaper that has biggest appeal for tradestore owners and workers: *Wantok*.

In addition to becoming a regular feature of *Wantok* along with the paper's strong news, sports, letters and advice pages, *Wantok Wholesale and Tradestore Supplier* will also be mailed directly to more than 3,000 buyers of bulk goods throughout Papua New Guinea.

We believe in business - and especially in the growth of PNG owned small businesses. And trade stores are the backbone of the PNG owned economy.

*Wantok Wholesale and Tradestore Supplier* will contain news of products and prices, educational items and tips on how to make better business.

It will include stories in both Tok Pisin and English.

And your news and opinions are welcome.

Please write to: **Wantok Wholesale and Tradestore Supplier**

P.O. Box 1982

Boroko

Phone 25 2500.

If you wish to be sure of your monthly copy, simply mail a cheque, postal order or cash to this address, for K10 for a year's subscription.

Anna Rongap

Editor  
Wantok

# Positive thinking puts store ahead

**THE manager of Parabu Trading, Henry Newton Kiambai, is a hard working, dedicated person with a positive attitude to running his trade store business.**

Mr Kiambai's trade store is situated in the township of Rabaul. It is at a stones throw distance from the main Rabaul market centre. A perfect place for such business because the area gathers large groups of impulse buyers daily.

There is a strong tie between Mr Kiambai and the wholesale companies which supply his store with goods. His store sells goods faster than most similar shops in Rabaul, outside the main market area.

Mr Kiambai gets a new supply of foods nearly every day. He says "This is a positive sign that my shop is going pretty well."

He sells almost all the kind of things one can find in big trade stores. Clothes are plentiful, groceries, frozen meat, chicken, lamb chops, fresh fish, tinned fish, ice cream, tea, coffee and sugar etc etc.

When Mr Kiambai goes buying goods, Rabaul B.P. Wholesale in town is the only distributor he calls at. At certain

times he might like to see what other wholesale businesses could offer him.

But otherwise Mr Kiambai says, "I only go to B.P. Wholesale. They offer the best services in Rabaul as far as I see it, which encourage me always to order my goods at their wholesale."

## Stocked

Mr Kiambai's store, "Parabu Trading," is a new business in Rabaul. He started the business in October 1983. However, it is now well stocked on the shelves, with more kept in his little office room behind the shop.

"I'm now thinking of re-constructing the building my shop is in, and enlarging it so that I can stock more shop goods for the customers to select and look at. I like to allow space for my customers to move around, so that there is enough room for 15 or so people to shop at the same time."

Mr Kiambai started his trade store with a loan of K10,000 from the Development Bank. He had his own K6,300 which was enough, he said, to propel him into starting and managing his trade store. He also used money belonging to a copra plantation business.

Mr Kiambai will be repaying the loan in the middle of this year. He says that the Development Bank will be paid in full plus the interest rate of K5,000. Mr Kiambai has the backing of his "Kambasrai" copra plantation. There is no doubt that he will pay back the loan on the marked date.

## Buyers

Even though Mr Kiambai owns both businesses, he has set his mind to run the two separately. The copra plantation spreads over 200 hectares. "From my copra sales, I make a minimum of K35,000 and a maximum of K50,000 a year."

Back in his trade store Mr Kiambai says, "More than 100 people step into my store daily, but the actual buyers would be about 65 to 70 each day. I have a little device in my cash register which counts the people when they stop over the counter to buy goods." From Monday to Friday each week, Mr

Kiambai receives ordered goods from BP Wholesale. The company distributes the goods to his doorstep which allows him ample time to work in the store not running around town ordering his goods. He has an account with the BP company and through this account, Mr Kiambai gets his order quickly and easily.

The future of Kiambai's trade store business is "great" he says. "I'm very positive that my business will emerge into a big shopping centre. It will take ten years for me to build my little store into a big one, but this is my high ideal. All I can do is work hard as I am doing now and watch my business as it grows."



• Newton Kiambai: he had to break down a side wall and extend, to add space for stock and for customers.



# WHOLESALE And Tradestore Suppliers

# Congratulations!

ON YOUR NEW PUBLICATION

From



**FORD  
COURIER  
UTILITY**



**CHECK  
OUT THE PRICE**

*Today!*

**AT**



## Meridien Motors

PORT MORESBY 252477 LAE 422869



**Wantok Wholesale and Tradestore Supplier**

# The genius in your pocket

**THE calculator may not be smarter than man, but it certainly thinks quicker.**

A calculator is a machine which does very quick arithmetic.

Inside the calculator is a tiny brain which is a silicon chip. This piece of metal which is no bigger than a thumbnail is the central and most important thing in the calculator.

Attached to this silicon chip is a circuit of many wires which are pasted together in copper on a plastic base. Also attached to this circuit are many other tiny wires.

## Button

When you press a button on your calculator, these wires act very fast carrying your request for your information to the silicon chip and bring back your answer in a space of seconds.

To operate a calculator, first switch it on. If you want to add K74.45 + K35.50 press 7,4 then the point, then 4,5 then the addition sign.

Then pres 3,5 then the point again, then 5,0 and the equals sign.

You then get your answer which is K109.95.

If you want to divide 240 by 12 press 240 then the division sign followed by 12 then the equals sign. Your answer is 20.

There are big and small calculators. The big ones use batteries or electric power and the small ones only use batteries.

The small calculator is known as the 'pocket calculator' and it uses two batteries. The battery with 'Liquid Crystal Display' or LCD is the best and lasts for many years.

## Fast

Trade-store owners in many villages of PNG have come to find calculators very useful. Because they are likely to make mistakes by giving wrong change to customers, the calculator can help them tell what

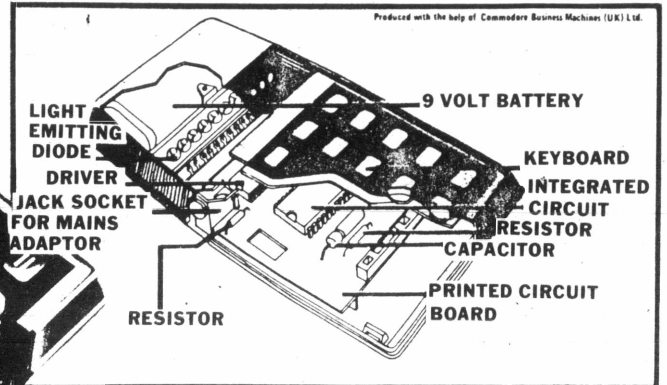
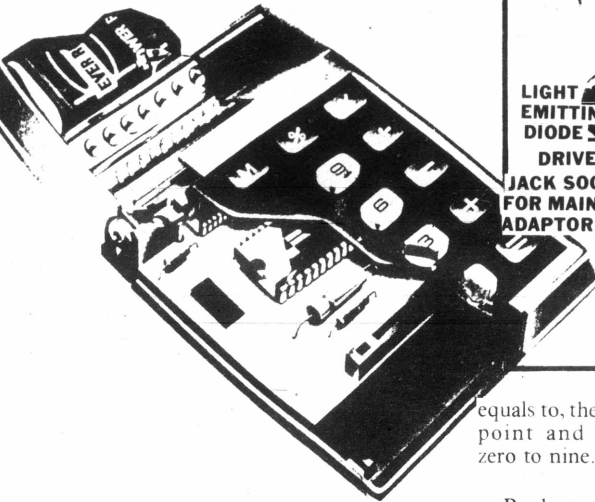

**THE calculator is increasingly becoming the tradestore owner's trusted friend and second brain. It is helping owners to do simple arithmetic quickly and is helping them to serve their customers quickly.**

• This is what the inside of a calculator looks like.

the right change is.

It also helps them to work out what profit or extra money they are making. It also reveals to them if they are losing money. In cases of stolen goods the

calculator tells how much money has been lost.

The face of the calculator has signs of addition, subtraction, multiplication, division, percentage, the

equals to, the dot or the point and numbers zero to nine.

Pocket calculators are in great demand in Papua New Guinea and apart from tradestore owners, teachers, students and individuals have also started using them in their work.

About 10,000 a year are sold here.

## Explain

A book entitled 'The business Arithmetic Workbook' which explains how to use the calculator has been written by Allen Edwards. It is written

especially for bussiness development officers in every province to help them explain to the village people how to use calculators. The book is written in English.

• Contact Mr Edwards at: Administrative College Box 1216 Boroko



# Markham Meats



**& SMALLGOODS  
PH: LAE 42 1069 or 42 1191**

**MANUFACTURERS, WHOLESALERS & SUPPLIERS OF**

- \* HAMS
- \* FRANKFURTS
- \* BACON
- \* CONTINENTAL SMALLGOODS
- \* SAUSAGES
- \* SAVELOYS

**\* FRESH BEEF \* LAMB \* MUTTON \* PORK \* FISH**

**DISTRIBUTIONS TO ALL AREAS OF PNG.  
SHOP & FACTORY**

**MOROBÉ AVE., P.O. BOX 1073, LAE  
TELEX: NE 44136  
PORT MORESBY 25 2932**



## Wantok Wholesale and Tradestore Supplier

# NOW IS TUCKER

PORT Moresby city has been invaded in its low-cost housing area and squatter settlements by crudely built stalls, numbering well over 500.

And even this rough figure obtained from the National Capital Interim Commission, may already have been exceeded. The commission is currently checking its files to see how many are

not supposed to be in business.

And of course, Port Moresby is no exception. The "tucker box" shops have been set up in town throughout PNG.

These kiosks are the start of commerce in low class housing areas, but at the expense of the city's "beauty." The services they dish out are vital to low-wage earners. After all, it was for the benefit of the disadvantaged-low

wage earners that the city's authorities gave the green light to locals interested in setting up small-scale business in these areas.

These kiosks, commonly labelled "tucker boxes," are virtually unknown in areas lived in by the elite. But they may crop up near grounds commonly used for sport and other public gatherings. A newcomer to Port Moresby is advised not to

ignore dusty looking caravans that look deserted at road-sides, when hunger pangs are intolerable.

For these "sorry-sights" sell life-savers to those who cannot afford bus rides to and from shopping centres.

These small stores only sell groceries and some other household items. All contain a refrigerator that enables them to sell cold drinks, and frozen

chicken.

The reasons underlying the creation of the new "fleet" of small, stores in the outer-lying suburbs of our towns vary from owner to owner.

### Creation

For the owner of Hura Trading, one of the many stalls at Gerehu stage 3, a trading business is just another means of increasing his revenue. This chap, from Morobe, already operates a PMV business and has his eyes open for more opportunities to present themselves.

And a second person is also benefiting from this particular trade store.

A man from Hula owns the building which houses the kiosk, and the Morobe man pays a fortnightly rent for the building together with a fixed sum of money for operating on the licence belonging to the Papuan. The Papuan decided to take a respite from business, which meant he was at risk of losing his trading licence.

To keep his licence valid he invited another man to operate on it until he is ready to make his come-back into the business world.

One piggery and poultry farmer from Wabag decided to extend his business to take in a trade store as well. Robby Samai is the owner of Rosala Trading Pty Ltd, which has two other branches, in Tokarara and Morata.

Fana Opoki, the Kainantu owner of Gerehu Corner Trading, had the idea of starting a business to test his managerial abilities.

But for Mr Woko, the owner of Woko Trade Store at Tokarara, his reasons for starting the project are more basic. He needs money from sources other than his pay to save up and to be able

to meet the cost of educating his children.

His entire fortnightly wage goes to meet food costs and water and electricity bill. Now, with the operation of his canteen, he says he is able to create a surplus that will finally end up in the bank.

### Operating

This reason for operating a store is shared by Mr Lavi the owner of Lavi Trading, operating at Tokarara, and Westcott Gegera, a trade store owner at Hohola.

It appears that the more established and prominent wholesalers are running out of favour from emerging trade store businesses. For Wantok's survey the nation's two front runners in the wholesale business are losing some appeal to potential customers, because it is claimed they are not prepared to do enough to assist in solving the problems faced by newcomers to the trade store business.

A retailer who has just started, without a truck to transport his goods to his store, will turn to wholesalers who have just that extra incentive, apart from offering lower prices - like offering delivery.

The small Hura Trading is attracted to Ocean Trading because of the speedy service provided by Ocean Trading. This wholesaler also allows its customers to obtain a variety of food stuffs through offering goods in small packs of sixes.

As the average money a small trade store owner would spend on just one order is in the vicinity of K300, the offer of 6-packs enables the starter to select a wide variety of goods.

Rosala Trading is an established small trade store. Its weekly expendi-

ture is around K3,000 as it has five branches scattered around the city to re-stock. Rosala Trading is supplied by Sun Yau Trading, Tokma Trading, Terimal trading Pty Ltd, and Seeto Kui (PNG) Pty Ltd.

These wholesalers allow credits to their customers on condition that debts are settled within a week.

### Transport

Tokma Trading and Leo Sam and Co Pty Ltd supply Fana Opoki's Gerehu Corner Trading. Fana stressed that Tokma Trading assists in providing transport and together with Le Sam, had prices he thought reasonable.

Another well-off small trade store with branches set up at several busy spots in Port Moresby, Baniel Trading, prefers Seeto Kui and Steamships ahead of other wholesalers.

A small trade store just emerging in Tokarara Woko Trade Store, prefers to stick with Jimm Trading Pty Ltd and Bulk Cash 'n' carry in its starting-up period. Woko believes that the prices of goods in these wholesale stores are cheap - just right for a starter.

Transport is provided by the companies, which means a reduced cost for the small trade store owner.

Mr Woko wants the K300 he spends on each order to obtain a good variety of food-stuffs in high demand in the suburb of Tokarara.

Only after passing that "weaning" stage does an established small trade store owner seem to start to obtain goods from the larger sources like Burns Philp and Steamships.

Usually by this time his savings would have secured a vehicle to transport the goods.

The owner of a new,



• The goods on display in Hura Trading are typical of many such stores. Two people are involved in the running of this store.

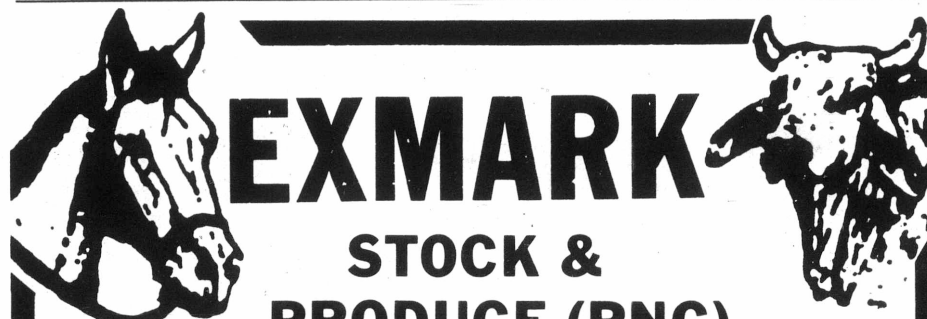

## EXMARK STOCK & PRODUCE (PNG)

FOR WHOLESALE & RETAIL  
SUPPLIES OF

- BLUDSTONE WORK BOOTS
- SADDLERY
- STOCK & POULTRY FEED
- FENCING MATERIALS
- VETERINARY PRODUCTS
- GARDEN PRODUCTS
- SEEDS & FERTILIZERS
- LIVESTOCK REQUISITES
- DIDIMAN EQUIPMENT

Office at:  
BOIO STREET  
EAST BOROKO

# 25 3560

Enquiries: PORT MORESBY  
P.O. BOX 6060  
BOROKO

Cables: "EXMARK"  
Telex: NE 23058



• Kata Trading in Tokarara has just started its operation, as indicated by these spaces on shelves yet to be filled.



## BOX TIME



● The building doesn't matter much to the owner of Rosala Trading. It's the money earned through sales of the goods that counts.

small store tends to be very careful where he spends his money. He pours most of his money into wholesalers whose goods are cheap and also provides transport.

Port Moresby, the nation's centre, with the second highest cost of living might lay some blame on small trade stores for their very significant contribution to the high cost of living.

Car-owners in the city have the advantage of buying their rations from main-stores at a cheaper price. Those who rely on their legs have had to bear with the high prices offered by the small trade stores.

### Rations

Thus low wage earners are paying more for their rations whilst the high income earners are spending less for the same foods. It is the majority — the grass roots — who are the hardest hit by trade store prices.

The obstacles to obtaining a licence are many, as pointed out by trade store owners and confirmed by the commission. First, an application is made out to the National Capital Interim Commission for a trading licence.

The commission has to wait for the land board to convene a meeting to trace the ownership of the piece of land sought. Then there is this question of whether or not to release the piece of land to the applicant if the land is found to be government land.

Then if the land in question is already on lease to the National Housing Commission there is the NHC to consult before any "Artifact" building is build next to a NHC house.

These procedures are time-consuming. Many months elapse before every relevant body to be involved in processing the application has made

its decisions. The commission then has to decide if a new small store

is necessary in the area where the proposed developer intends to set it up.

A Commission official explained that licence was "readily" granted to an interested person intending to set up a store in an area where not very many residents are likely to own a car. But one wonders if very strict criteria are followed when the commission scrutinises each application.

Everywhere it seems trade stores are set up within a couple of minutes walking distance from each other.

Many trade stores owners admit that their weekly earnings are not as high as they had hoped. There are very many stores concentrated in one small area which paves the way for customers preference as the determining factor in whose store gets how much.

### Revenue

Only those small stores that provide an around-the-clock service are able to make good money each week. Rosala Trading has a daily earning of about K1,000 and this revenue is surpassed to K2,000 or K3,000 on Fridays and Saturdays for obvious reasons.

High income-earners use these stores at night time, while during day time and in the early hours of the evenings it is almost exclusively a grass-roots store.

Other small store owners who cannot operate on a 24-hour basis resort to other attractions to attract their customers, allowing customers to take away goods on credit and repay later guaranteeing an influx of money on "fortnight" days.

But for most small store owners the chance of a four digit weekly return is remote. One trade store in Hohola sells K37 worth of goods per



● The crude structure which houses Daniel Trading in Gerehu. These brown caravans can be spotted in several parts of the city, a "trade mark" for Daniel Trading.

day. Most store owners say they earn around K200-K300 a week.

But most store owners are happy with whatever they have achieved so far. Most have plans to expand their business if things go well. But they would have to need all the luck in the world to obtain enough land to accommodate a bigger store.

Although prices in these shops may be terrifying, customers have little choice but to accept them, while wholesalers will be only too happy to see the survival of small businesses, as their continued existence means business to them too.

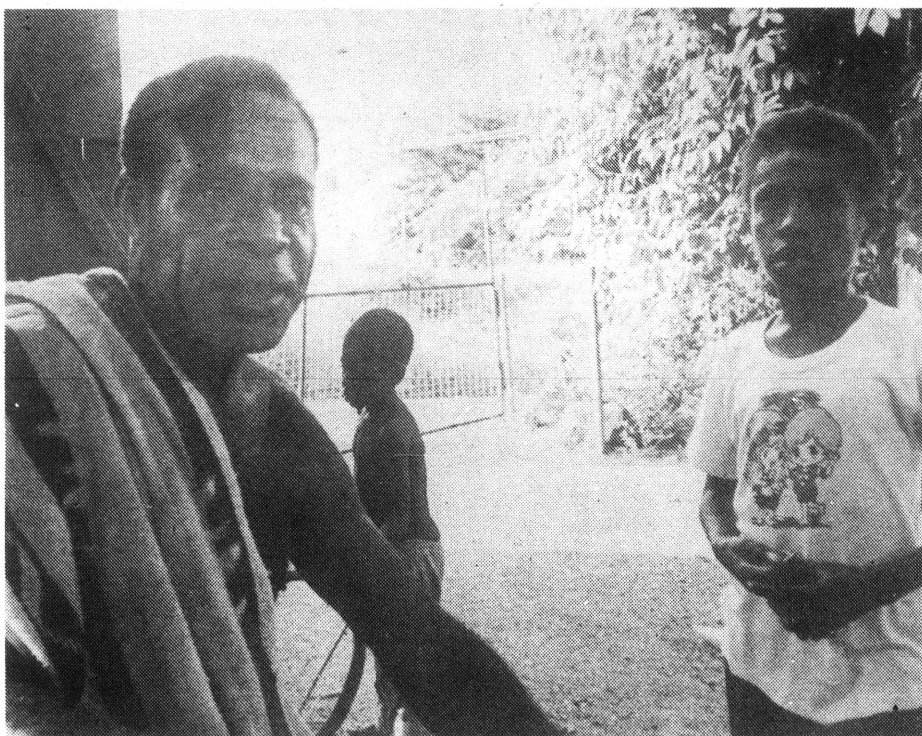

● Mr Woko, he was hard-pressed by financial difficulties to the point when setting up a store seemed the only solution.

## Frozen foods special in May Supplier

NEXT months issue of Wantok Wholesale and trade store supplier will carry an extensive survey into the refrigeration and frozen food industry, and supplies to the bulk buying industry.  
● Publishing Date May 23.  
● Deadline for editorial/advertising May 18.  
● For advertising call 25 2500.



# ROSEMARY'S

## Wholesale and Discount Mart

(Situating Munahu Street, Gordons)  
next to Dunlops

**We are wholesale specialists in the following lines:**

### CLOTHING..

Mens, Womens, Children & Babies.

Look at these low, low prices:-

- \* Mens T shirts - K10-18 per dozen
- \* Boys Hawaiian style shorts - K9 per dozen
- \* Quality Mens Underpants - K4-50 per dozen.

### MANCHESTER..

Sheets, towels, Blankets,  
Baby Blankets, Tea towels etc.

Pharmaceuticals - Toilet soap, toothpaste,  
toothbrushes, Hair oils and Creams, after shave  
lotions, Bandaides, cotton buds, perfumes etc etc.

**Many styles and sizes to choose from**

**Complete and full range at more than competitive prices.**

### TOYS..

We have a wonderful range of cheap, cheap toys including guns, cars, aeroplanes, Harmonicas etc, etc, plus balloons and marbles.

Buy early while stocks last.

### STATIONERY..

Compare these prices:-

- \* Exercise Books, large K3-20 per dozen
- \* Exercise Books, small K1-45 per dozen
- \* Universal Ball pens K1-85 per dozen
- \* Pencils with rubber -57 per dozen
- \* Airmail writing pads K3-06 per dozen
- \* Airmail Envelopes K3-20 per carton

a comprehensive range

### KITCHENWARE..

A marvellous selection of cheap enamel ware, coffee mugs, dinner plates, dinner sets, cutlery, frying pans, cauldrons, kerosene stoves etc. etc.

Haberdashery - cotton, needles,  
buttons, Materials 75t / Yd  
various patterns available

Rosemary Roy Pty Ltd.  
Phone: 258414

The above are just a few of the lines that we keep in our fully stocked warehouse and showroom. Call in and inspect what must represent the LARGEST range of trade goods at the CHEAPEST prices in Port Moresby.

Should you wish our Salesman to call with a full range of samples and price lists then merely pick up the phone, dial 258414 and ask for Ezekiel Gerenua or Jon Roy.



# Wantok Wholesale and Tradestore Supplier

**Rush me my Wantok Wholesale Supplier!**

Wholesale and Trade Store  
Supplier Subscription Dept  
P.O. Box 2213 Boroko

Brilebo block No 180  
P.O. Box 18 Mearua  
Imogen Bay Central Province  
11-1-84.

Dear Sir,

Am contacting you for the purpose of 12 months  
subscription.  
In some ways am running a trade store so I need you to  
let me know the details about the wholesale and T/store  
supplier.  
If you give me more details than am gone to send you  
K10.00 with the 12 months subscription.  
So that I can order some goods from the company.  
Hope to received more details from you soon.  
Am enclosing the business letter here

Yours faithfully



David B. Micky

• If you, like tradestore owner Mr Micky, want to make sure of your monthly supply of Wantok Wholesale and Tradestore Supplier, Send K10 to P.O. Box 1982, Boroko.

## What will sell well in May

THE following companies are planning advertising campaigns for May. Trade Stores can expect increased sales of these products and are advised to increase their stocks accordingly.

**Ramu Sugar** — are planning corporate ads for their sugar in press, radio and cinema until the end of the year.

**Eveready Batteries** — All newspapers and radio.

**National Batteries** — Other products — newspapers and radio.

**Johnson and Johnson** — Hygiene, Baby care products: press.

**Fuji Film** — Press.

**Sakura Film** — Press.

**Tulip canned meats** — Press.

**Paradise Biscuits** — Cookies, Milk 'n' Bran bread — Press.

**Morobe Bakery** — Cream biscuits, Wopa biscuits, PNG crackers — Press, radio and cinema.

**Reckitt and Colman** — Big Sister, Pino-O-Cleen, Dettol antiseptic, Disprin, Mortein insect killer — radio only.

**Coca Cola** — Radio.

IF you wish to let trade stores know of your advertising back-up please call Anna Rongap on 25 2500 in time for next month's issue.

# WOO TEXTILE CORPORATION

PTY LTD

**MANUFACTURERS & EXPORTERS OF HIGH QUALITY  
SPORTSWEAR, UNIFORMS AND FASHION GARMENTS**



**OFFICIAL AGENT AND MANUFACTURING LICENSEE  
OF WESTMONT ACTIVE SPORTSWEAR**

**WE ARE THE LEADING T-SHIRT MANUFACTURERS IN  
PAPUA NEW GUINEA**

**P.O. BOX 5448, BOROKO. PHONE 25 5097 or 25 7863**

**TELEX NE 22347 WOO**



# National

## National Battery



- STEEL JACKETS
- PLASTIC SEALS
- DON'T LEAK
- LAST LONGER

Full range of high quality National batteries NOW available

QUANTITY DISCOUNTS

## National Radio Cassette



Complete range of high quality products — parts and service back up guaranteed

APRIL SPECIAL  
RX-1280w plus free  
torch K53.00 only

## National Torches

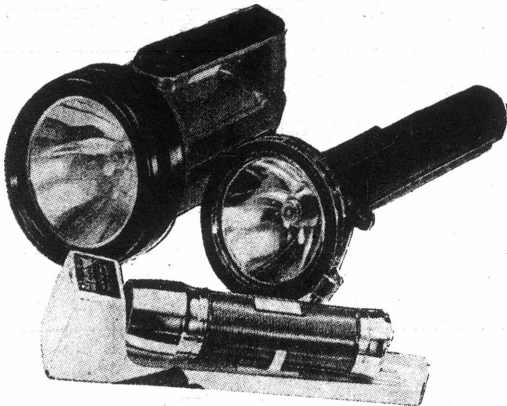

Wide range of new stocks just arrived. Quantity and cash discounts available.

W/SALE SPECIAL  
FF-135CE K2.98  
FF-191 K5.00

PLUS: Hi Fi equipment, calculators, electrical appliances

FOR WHOLESALE ENQUIRIES  
PLEASE CONTACT

## National TV Video

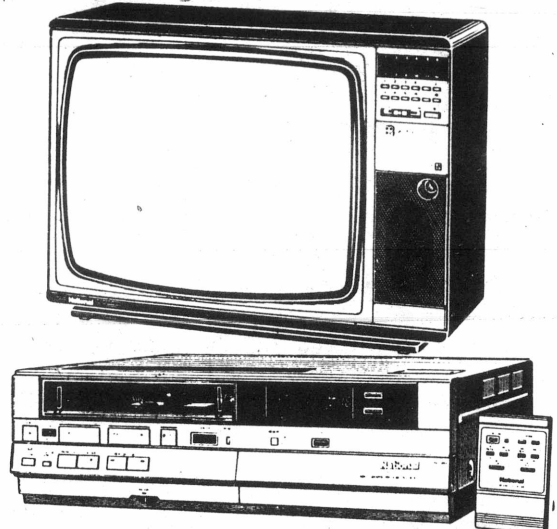

At last, a range of high quality video and television equipment, including:

Wholesale

NV-370 front loading VCR	752
NV-600 infra-red remote, "super still." VCR	877
NV-100 portable VCR	947
TC-1407 14" T.V.	480
TC-1810 18" T.V.	548
TC-211m 20" T.V.	675
TC-2000 Eum Video Monitor	799
WV-P35 Video Camera - 200m	933
WV - P35 Video Camera - 6 times Zoom	
WV-P55 Video Camera - auto focus	1111
6 months warranty period	

# CHIN H MEEN AND SONS PTY LTD

WHOLSALE DIVISION

GORDONS  
PH: 256430

LAE

2nd St  
Ph: 423035

Kamarere St

RABAU  
Ph: 921107

# CHM



# WHOLESALE Special

## SAKURA

High quality colour film known throughout  
Papua New Guinea

## SEIKO

K39.95 Ladies Digital & Gold Bracelet  
K45.00 Gents S/S automatic D/D  
Ladies & Gentlemens Watches, high quality service  
backup

## PNG CASSETTES

— K2.35  
TO K3.30

## SOUTH PACIFIC CASSETTES

New Zealand  
Tonga  
Samoa  
Fiji  
from K3.95

**FOR WHOLESALE ENQUIRIES  
PLEASE CONTACT**



WHOLSALE DIVISION	LAE	Kamarere St
GORDONS	2nd St	RABAUL
PH: 256430	Ph: 423035	Ph: 921107





# MORE STORAGE SPACE!

**720 Pickup Ute**



When you are picking up bulk supplies, look for a vehicle that gives you more space.

**LOOK NO FURTHER THAN BOROKO MOTORS**

**At your Nissan Dealer.** *I'm ridin' my way!* with **The GOOD GUYS**

BOROKO MOTORS - 25 5255 - Port Moresby  
 BOROKO MOTORS - 42 1144 - Lae  
 BOROKO MOTORS - 92 2777 - Rabaul  
 BOROKO MOTORS - 82 2433 - Madang  
 BOROKO MOTORS - 52 1433 - Mt Hagen  
 ARAWA MOTORS PTY. LTD. - 95 1566 - Arawa  
 HIGATURU MOTORS PTY. LTD. - 29 7175 - Popondetta  
 PROVINCIAL AGENCIES PTY. LTD. - 94 2131 - Kavieng  
 TORA MOTORS PTY. LTD. - 57 4059 - Wapenamanda  
 MILNE BAY ENTERPRISES - 61 1167 - Alotau  
 WEWAK DATSUN AND MARINE - 86 2220 - Wewak



**BOROKO MOTORS**

BOROKO MOTORS - 25 5255 - Port Moresby  
 BOROKO MOTORS - 42 1144 - Lae  
 BOROKO MOTORS - 92 2777 - Rabaul  
 BOROKO MOTORS - 82 2433 - Madang  
 BOROKO MOTORS - 52 1433 - Mt Hagen  
 ARAWA MOTORS PTY. LTD. - 95 1566 - Arawa  
 HIGATURU MOTORS PTY. LTD. - 29 7175 - Popondetta  
 PROVINCIAL AGENCIES PTY. LTD. - 94 2131 - Kavieng  
 TORA MOTORS PTY. LTD. - 57 4059 - Wapenamanda  
 MILNE BAY ENTERPRISES - 61 1167 - Alotau  
 WEWAK DATSUN AND MARINE - 86 2220 - Wewak



# Stret na smat pasin bilong Jack na Givani



● Givani na Jack wantaim tupela pikinini bilong tupela, Clara na Dick, i sanap insait long Borogaino Treding stua bilong ol long Hohola, Mosbi.

**LONG ol 6-pela yia i go pinis, Stretpasin Treding i bin olsem laip bilong Jack na Givani Nia. Stat long 1982 i kam inap nau Jack wantaim meri bilong em Givani i kamap wanpela tim stret, na papa bilong Borogaino Treding i stap long Hohola namba 4 long Mosbi.**

Wokmani na bisnis i isi long tupela long wanem tupela wantaim i greduet wantaim bisnis developmen setifiket long Laloki Bisnis Developmen Koles.

Olsem Jack i bin tok aut, "Rot bilong ranim bisnis bilong yu yet, maski bikpela ol liklik i hat tru long lukautim gut wok mani. Tasol putim gut nem bilong yu long gut na klia long rekot i bikpela salens i gat bikpela hat wok tru long olgeta kain bisnis."

Em i tok, "Em i samting bilong skin les na ai slip long sindaun insait long stua tasol olgeta taim na lukautim ol wokman na was long nogat mistek mas kamap. Tasol i hat wok tru tu long kisim ka ran i go kam long putim nupela oda, i go long beng o stretim ol kain kain liklik wok bisnis tu."

Jack Nia i kam long Mubumiang Viles long Saidor Distrik, Madang provins. Em i gat 28 krismas. Na Stretpasin treding bisnis i kamap bikpela tru long em nau. Na seketeri bilong Jack, em meri bilong em Givani husat i save lukautim ol akaun buk raitim na sekap olgeta bilong dispela bisnis bilong tupela.

Dispela em i hap wok em Givani i bin mekim taim em wok bipo long Developmen Beng yet. Na em i save tru long dispela wok na i nogat

wari o hevi i kamap long tupela.

## Viles

Na Givani i kam long Kemabolo Viles long Rigo Distrik bilong Sentral Provins. Givani i bin wok pastaim long Developmen Beng long Mosbi. Na em i wok long seksen we em i save gut long ol lo na pasin bilong Stretpasin treding.

Tasol Jack i no wok insait tru long dispela seksen. Nogat. Em i bin wok olsem supavaisa. Em i bin wok wantaim Developmen Beng na i save i go raun sekap long wok mani bilong olgeta Stretpasin stua long Mosbi. Na em i save raitim ripot i go long beng.

Bihain long 1979 Novemba tasol Givani na Jack i kisim dispela Borogaino Treding long Hohola. Tasol dispela taim tupela i bosim na lukautim tasol. Na stua i bin i stap yet aninit long nem bilong Developmen Beng.

Na long 1980 beng i transferim i go long nem bilong tupela olgeta, olsem Jack Nia i papa nau long dispela stua. Dispela ful transa i mekim Jack wantaim Givani i pinisim olgeta wokmani wantaim beng. Na long pinisim nem bilong Developmen Beng tupela i peim K90,000 (90 tausen Kina) olgeta.

Dispela tupela manmeri i gat gutpela nem wantaim beng long wanem tupela inap long baim pinisim olgeta dispela stua long K80,000 tasol tupela yet i sukurim wanpela hap stua gen. Em nau tupela i yusim olsem bakstua long putim ol bek rais, bek suka, kes tin mit, fis na ol kain samting.

Dispela wok bilong sukurim hap stua i kos narapela K10,000, we i

mekim K90,000 olgeta.

Stat long 1980 i kam inap nau em Jack i papa bilong stua bisnis bilong em is ave kamapim K13,000 long olgeta mun. Dispela em mak bilong mani i save kamap insait long stua tasol.

## Papa

Jack i tok, "I gat tupela stua tasol i stap long dispela eria i save skelim hamas ol pipel bilong dispela eria. Wanpela em stua bilong wanpela man bilong Saina. Tasol nau wanpela lokal man yet i bin baim na nau em papa long en. Sapos 3-pela o, moa stua i stap bai i hat liklik. Mak bilong win mani bai i go daun liklik."

Jack i tok, "Wanpela gutpela ples tru long Mosbi long dispela bisnis em long Gordens dispela mipela i save kolim "Gold Main" maski wanem taim long de moning o apinun mani i kapsait i go insait long stua yet.

Long wanem i gat maket i stap klostu, ol skul, eria ol pipel i stap long en, na ol pipel i laik i go aut long haive o i kam insait long siti i kapsait long dispela eria tasol.

Na stua bilong Gima Kini i stap long dispela eria we em i no save kaunim, mani i save kapsait tasol. Gima i stat bihain long mipela, tasol dispela eria stua bilong em i stap long en tasol na wokman bilong em i winim bilong mipela olgeta.

Insait long Stretpasin Treding bisnis meri bilong man Beng i luk-save olsem meri bilong man i kamap autometik patnasip wantaim man bilong em. Dispela i min olsem em i gat nem long hap bilong dispela bisnis. Aninit long lo bilong beng na ol pepa wok tupela manmeri wantaim i skelim wokmani bilong

dispela bisnis.

Jack i tok aut olsem "Hia meri bilong mi i kamap eksekutiv seketeri na mi yet bos. Dispela em i kampani bilong em yet." Em tok long Borogaino Treding em i kampani bilong em yet. Dispela luksave i stap aninit long beng.

## Stilman

Long eria em nau Borogaino Treding i stap long en, Jack i tok wanpela bikpela problem tru em i save lukaut gut tru long ol stilman o trabelman long brukim stua o kukim stua long paia na i go insait long stilim samting.

Planti taim ol yangpela man i save i go insait long stua giaman long baim ol samting, raun tasol na traim stilim ol samting insait long stua, haitim samting insait long ol klos na ranawe wantaim.

Dispela em i bikpela hevi tru long stua bilong em.

Tasol i nogat wanpela taim trabel man i bin brukim stua bilong em. Jack i tok wanpela taim dispela kain i bin laik kamap. Na Jack yet i askim ol komyuniti lida bilong Hohola namba 4 wantaim papa bilong narapela stua i stap klostu long stua bilong em na i kamap wanpela sosial komiti long lukaut gut long ol kain raskal pasin.

Tasol em i tok em wantaim ol komyuniti lida i save bung na kisim ol yangpela manmeri i stap nating na skulim ol kamap gutpela sitisen. Na i no ken bagarapim nem na laip bilong ol yet.

Em traim kamapim gutpela pren wantaim olgeta pipel long komyuniti long wanem stua bilong em i stap long eria long we planti kain raskal pasin i save kamap.

Jack i tok, "Nau ol

husat i laik bringim hevi i go long komyuniti na mipela ol lain i hat long kamapim ol bisnis i luksave long sindaun bilong mipela olgeta nau.

"Tasol mi save lukaut yet na was gut tru long trabel o birua i no ken kamap long stua na sindaun bilong mi o ol wokman bilong mi na famili bilong mi tu."

Sampela bilong ol trabel man i pilim pinis long wanem taim Jack i belhat tru na karim wanpela yangpela man husat i bin laik bagarapim bisnis bilong em i go long ka bilong em antap long Sogeri na i mekim pretim em olsem bai em i tro-moim em i go daun long maunten na pundaun na indai olgeta o brukim bun long lek, han bilong em.

## Wari

Tasol long ranim stua na wokman bilong bisnis i no bin givim bikpela wari o hevi tumas stat long taim Givani na Jack i kamap papa bilong Borogaino Treding.

Jack i tok, "Mipela wantaim i kisim skul pinis long bisnis developmen na mipela tupela wantaim i wok long Developmen Beng bihain long tupela i greduet long koles. Olsem na tupela i save long olgeta kain liklik pasin bilong wokman bilong Stretpasin pinis."

Tasol long dispela taim tupela i pren tasol i no marit taim tupela i wok long Beng. Long 1978 wan yia bihain long tupela i greduet na tupela i marit. Nau tupela i gat 3-pela pikinini, tupela pikinini man Gosa 5-pela krismas na Dick, na pikinini meri Clara, 9 mun tasol.

Taim Givani i mekim ol transeken wok bilong Stretpasin Treding seksen insait long Developmen Beng i soim rot

bilong tupela. Na em i lukim i gat wanpela wok olsem advaisa bilong ol stua i stap nating, olsem Jack i ken aplai na kisim dispela wok. Dispela taim Jack i stap long Madang. Taim Givani i tok save long em Jack i aplai na kisim dispela wok.

Jack i tok, "Taim mi save raun olsem advaisa long ol menasa bilong ol stua em i taim we tingting bilong mi i kirap long mi yet i laik traim ranim wanpela stua yet. Long wanem mi bin lukim bikpela mani tru long ai bilong mi em ol stua i save kamapim olgeta mun na yia.

"Mi putim bilip na tingting i go daun olgeta na hia nau em mi kamap papa bilong wanpela stua pinis."

## Hausing

Givani wantaim Jack i baim wanpela Hausing Komisins haus i gat 3-pela rum long en long Hohola namba 4 yet. Tupela i kisim dinau long dispela nupela gavman garenti skim na baim long K10,000 (10 tausen Kina).

Jack i tok, "Mitupela inap long bekim hariap long mak bilong 3 mun tasol. Tasol long mekim nem na kamapim gutpela nem tu bilong sampela wankain wok olsem beng bihain mitupela i bihainim olgeta lo bilong ol na bekim long mak beng i makim long en."

Jack i tok, "Dispela haus i bilong bisnis bilong em, we ol 7-pela wokman ol stua boi i save i stap long en. Tasol em i gat narapela haus, i stap long Madang tupela i bin baim long K5,000 (5 tausen kina).

"Dispela long Madang em i praivet haus bilong

tupela yet. Wanem taim tupela i go long Madang i ken yusim na nau em i go aut long ol narapela lain. Em tu wanpela long ol hausing komisins haus i gat 2-pela rum tasol."

Jack i save baim ol oda bilong em long ol holsel olsem BP Badili na ol arapela holsel i stap long siti. Na em i save putim oda olgeta de.

Givani i tok, "Mipela save baim nupela oda olgeta de. Tasol i no bikpela tumas, liklik tasol."

## Oda

Bipo ol Stretpasin Treding stua i save kisim oda bilong olgeta samting long Ocean Treding. Tasol nau i hat long wanem planti stua aninit long dispela skim bilong Developmen Beng i kamap. Na i hat long Ocean Treding i kisim oda i kam long Hongkong olgeta taim long makim olgeta oda bilong dispela ol stua.

Aninit long dispela skim ol man i ranim stua na i no kamap papa bilong stua yet, i no peim dinau. Ol i stua menasa tasol olsem wokman bilong beng na beng yet i papa long ol dispela stua.

Na beng i baim fotnait pe bilong maneri na ol wokman bilong stua tu inap taim beng i tranferim stua olgeta i go long nem bilong dispela menasa na em i kamap papa bilong stua. Hia em we bisnis i baim pe bilong em na meri na ol wokman tu.

Jack i tok sampela taim bihain em i tingting long i go long Madang. I no long ranim moa long Stretpasin Stua bisnis, tasol mekim narapela wok. Tasol dispela em i lukim olsem wanpela driman.



**Wantok Wholesale and Tradestore Supplier**

# BPs to push stationery

AS OF this month, Burns Philp, which has always concentrated before on food in its wholesale outlets throughout Papua New Guinea, is venturing into stationery wholesale.

A spokesman of the Burns Philp's Badili wholesale outlet, Mr Graham Stevenson, said that BPs had not really got involved in stationery wholesale before. However, after a number of months research into what has been coming into the country from overseas, and into the needs of the customers the company decided to invest money in this new venture.

Schools, offices, tradestores and various groups who want to buy in bulk will be able to get their stationery supplies from the 11 Burns Philp wholesale outlets in the country.

A representative of the company will be travelling throughout the country with a sample of the stationery.

"Customers have found it very beneficial to buy quality material from Burns Philp, and we will be giving them value for their money" stressed Mr Graham.

## Importing

Apart from Australia, the company will be importing material from South East Asia, with a special emphasis on quality writing pens from Japan and paper from Singapore.

A wide range of books, rubbers, pens, pencils and other material will be made available at the outlets.

The 11 wholesale outlets for Burns Philp include Kavieng, Kieta, Rabaul, Lae, Goroka, Kiunga, Mt. Hagen, Madang, Wewak, Popondetta, and Badili in Port Moresby. At present, Rabaul, Lae and Badili are the three biggest wholesale outlets of the company.



• Checking on stock at a Burns Philip store: soon stationery will take a bigger profile.

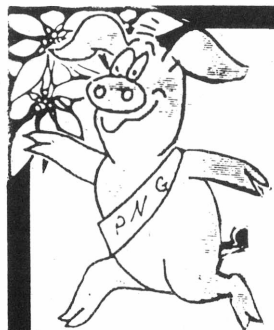

**sapphire**   
**smallgoods** pty ltd

P.O. BOX 1785 BOROKO

**BEST QUALITY SMALLGOODS MANUFACTURERS**

**ATTENTION: MR RETAILER  
& MR FAST FOOD MANAGER**

**"SUNSHINE SAVELOYS"**

**WIN A FREE CARTON AND INCREASE YOUR PROFIT**

**WHEN** — ALL THROUGH MAY 1984

**HOW** — BUY "SUNSHINE SAVELOYS" FROM YOUR FAVOURITE WHOLESALER AND LOOK INSIDE FOR A "SUNSHINE SAVELOYS" SPECIAL LUCKY LETTER

**WHICH ENTITLES YOU TO A FREE CARTON OF  
"SUNSHINE SAVELOYS".**

**IF YOU WIN TAKE THIS LUCKY LETTER BACK TO YOUR WHOLESALE  
MANAGER WITH YOUR NEXT ORDER AND HE WILL GIVE YOU AN  
EXTRA CARTON OF "SUNSHINE SAVELOYS" FREE**

**REMEMBER — WE ALSO MANUFACTURE BEST QUALITY  
HAMS, BACON, SAUSAGES, FRANKFURTS AND FINE  
CONTINENTAL SMALL GOODS FRESH EVERYDAY.**





# EVEREADY®

## PACKS POWER



Buy Eveready® and you buy a battery with a performance equal to, if not better than, any other battery available on the market today. And when you buy from Burns Philp that's not all you get. We also give you

- \* FREE Dealer Kits
- \* FREE Display Stands
- \* FREE T-Shirts, torches and caps as giveaways.

All of which adds up to total marketing support from Burns Philp

Remember Eveready® is a better product at a better price. Remember too that only Burns Philp offers you a full range of Eveready® products.

HRD 4711

**Burns  
Philp**



**TRUE WHOLESALE VALUE-  
FOR-MONEY NATIONWIDE**



# Burns Philp



# WHOLESALE TRUE VALUE FOR MONEY GROCERY BUY BETTER IN BULK

<p><b>Sunflower Mackerel in Natural Oil</b> <b>K20.20</b> 48x425g</p> 	<p><b>Orange-Mango Tang</b> <b>K36.90</b> 12x750g</p> 	<p><b>Sunshine Instant Milk Powder</b> <b>K21.75</b> 6x1kg</p> 
--	---	---

<p><b>Johnson &amp; Johnson Modess - Regular</b></p>  <p><b>K54.65</b> 48x10's</p>	<p><b>Zixo Bleach</b></p>  <p><b>K12.25</b> 12x750mL</p>	<p><b>Pecks Braised Steak &amp; Onions</b></p>  <p><b>K28.00</b> 24x425g</p>
<p><b>Johnson &amp; Johnson Modess - Super</b></p>  <p><b>K61.45</b> 48x10's</p>	<p><b>Nestle's Baby Food in Jars</b></p>  <p><b>K8.60</b> 24x125g</p>	<p><b>Kraft Processed Cheese</b></p>  <p><b>K28.65</b> 48x250g</p>
<p><b>Trix Dishwashing Liquid</b></p>  <p><b>K11.85</b> 12x.500mL</p>	<p><b>Palmolive Toilet Soap</b></p>  <p><b>K26.75</b> 72x125g</p>	<p><b>Nescafe Espresso</b></p>  <p><b>K20.00</b> 24x50g</p>
<p><b>Morobeen Kokonat Kina</b></p>  <p><b>K9.45</b> 24x200g</p>	<p><b>Petal Toilet Rolls</b></p>  <p><b>K22.75</b> 72's</p>	
<p><b>Peanut Cookies</b></p>  <p><b>K10.60</b> 24x200g</p>	<p><b>Cock Mosquito Coils</b></p>  <p><b>K85.00</b> 300's</p>	



**Burns Philp**  **TRUE WHOLESALE VALUE - FOR - MONEY NATIONWIDE**



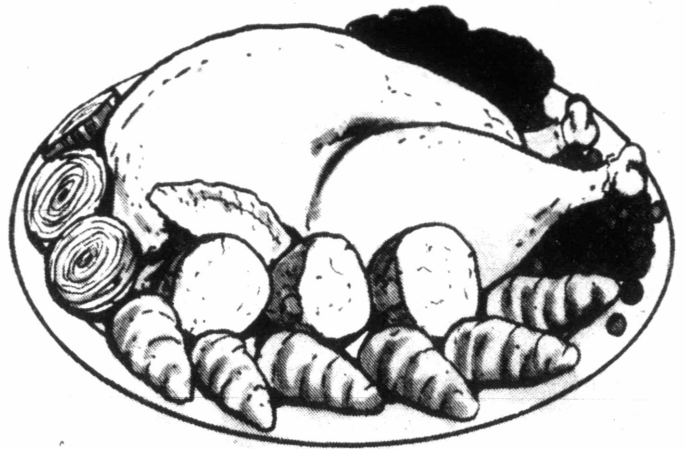

# SPECIALS DELICIOUS TASTING CHICKENS NATIONWIDE SAVINGS



CHECK YOUR LOCAL BURNS PHILP  
WHOLESALE OUTLET FOR THE RANGE  
AVAILABLE

 <p><b>K72.77</b> No 9x27</p>	 <p><b>K71.16</b> No 13x19</p>	 <p><b>K70.41</b> No 11x22</p>
---	---	--

 <p><b>K65.04</b> No 8x27</p>	 <p><b>K61.26</b> No 10x21</p>	 <p><b>K59.04</b> No 12x17</p>
--	--	---

Kraft Cheddar Slices



**K26.00**  
24x250g

Kraft Coon Cheese



**K54.00**  
48x250g

CHICKEN PORTIONS AVAILABLE-  
LEGS, WINGS, COCKTAILS, LIVERS,  
BREASTS, THIGHS, GIBLETS,  
SOUP PACKS  
PLUS LAMB—Flaps,  
Forequarter Chops, Tongues &  
Neck Slices  
FISH—BEEF—PORK  
AND ICECREAM-EGGS-  
ORANGES-APPLES-ONIONS-  
POTATOES.

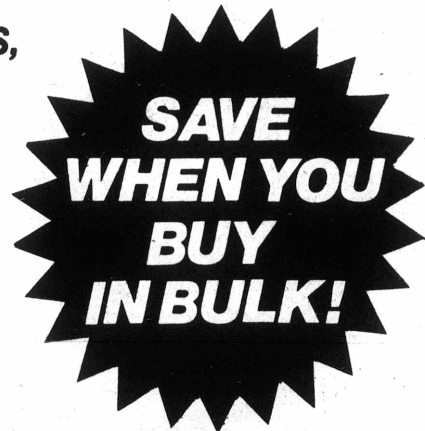

## Burns Philp



**TRUE WHOLESALE VALUE-  
FOR -MONEY NATIONWIDE**



# Stock up with Wholesale value from Burns Philp

Spicers Tudor Envelopes 405x305

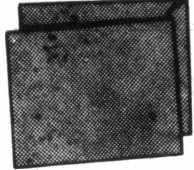

**K40.75**  
(Box 250)

'Olympic' Short Hand Books

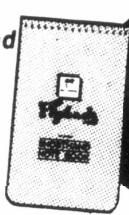

**K2.25**  
box

Elephant Paper Clips



**20†**  
box

**Save on Stationery all year round!**

Spicers Tudor Envelopes 230x150

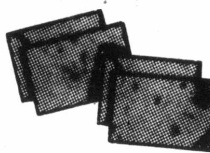

**K28.25**  
(Box 500)

Check Tickets Books



**20†**  
box

White Envelopes (500)

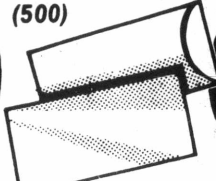

**K9.95**  
box

Spicers Tudor Envelopes 350x255

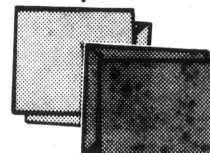

**K24.99**  
(Box 250)

Faber Castell Yellow, Blue, Orange Highlight Pens



**K13.35**  
box  
K1.35 each

Lead Pencils



**K7.75**  
gross

'Olympic' 2 Ring Binders

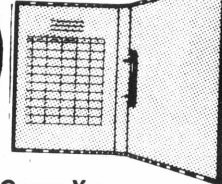

**K3.20**  
each

'Olympic' Spiral Note Books



**K2.15**  
each

Collins Account Books

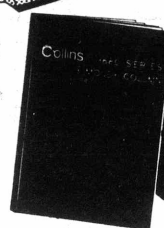

**K6.99**  
each

Gung Yu Files

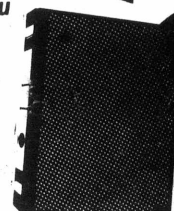

**K2.05**  
each

Excelsior Clip Boards

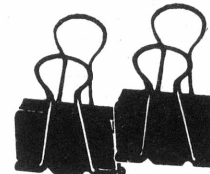

**22†**  
each

Canary A4 Student Pads



**95†**  
each

**Real Wholesale Prices!**

Plastic Clip Files



**K13.75**  
dozen

Masonite Clip Boards



**K2.25**  
each

Excelsior Punches

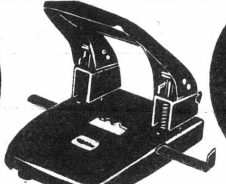

**K2.25**  
each

Mitsubishi Ball Pens



**K3.95**  
dozen

'Olympic' Big Spiral Note Book



**K2.15**  
each

Golden Axe Markers



**K15.20**  
dozen

**See the rest of our huge range!**

Mitsubishi Mat Ball Pens



**K4.75**  
dozen

Office Writing Pads



**K1.20**  
each

Golden Axe Markers



**K5.40**  
dozen

Mitsubishi Marking Pens

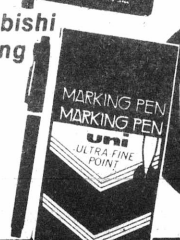

**K3.20**  
dozen

Collins Analysis Books No. 61 Series 8 - 32 Columns

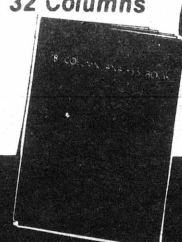

**K6.99**  
each

JHRD 4655

**Burns Philp**



**TRUE WHOLESALERE VALUE FOR MONEY NATIONWIDE**  
(If you don't believe us compare our prices!)

# **AS IN 1984!**

**CONDUCTED AT THE DEPT  
USING GAS, ELECTRICITY  
NG FUEL.**

**WISE UP — GO FOR GAS!**

**N BE**



**THE NEW 2 BURNER  
GAS STOVE INCLUDING  
REGULATOR, HOSE,  
CLAMPS + 4.5 KG GAS BOTTLE +  
GAS & AUTOMATIC IGNITER**

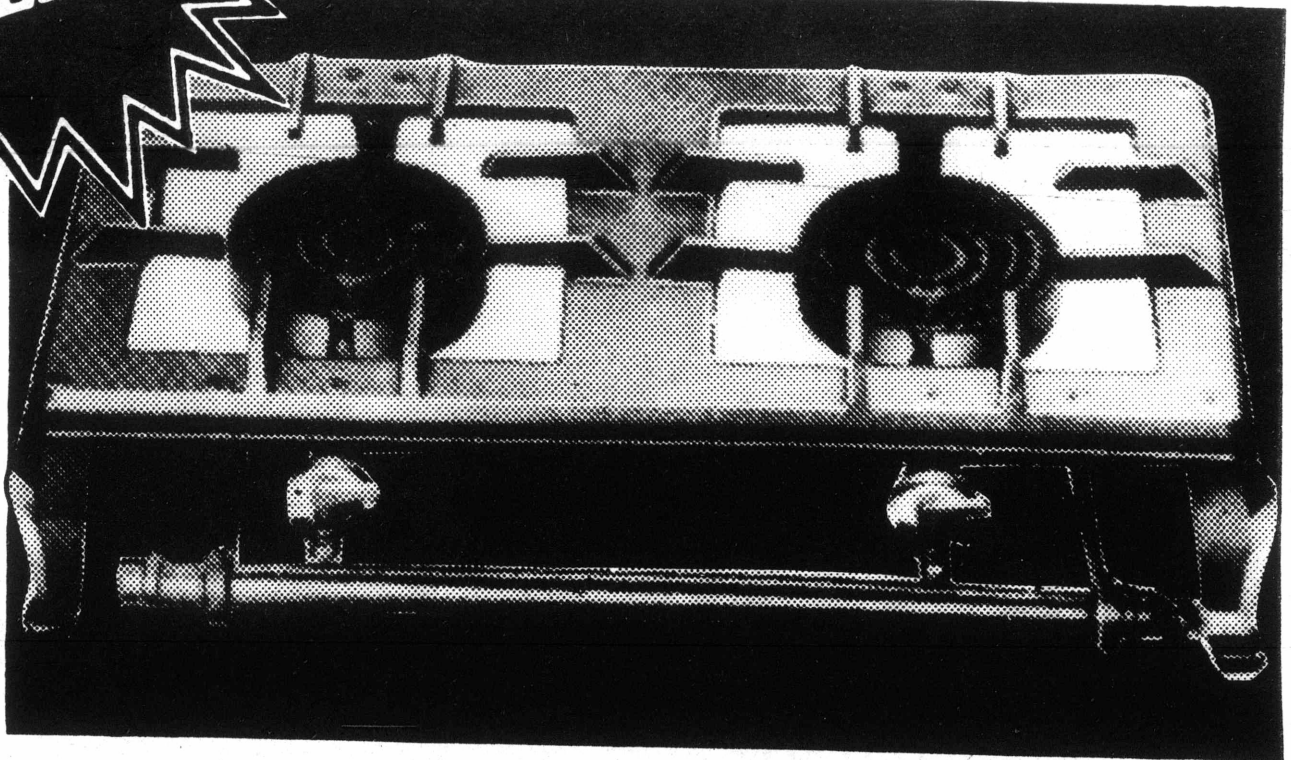

**E**

**S**

**antages of cooking on  
I 4248**

**WHOLESALE PRICES ON APPLICATION TO  
BORAL GAS (PNG) P/L.,  
TEL 21-4248**





**Paradise**

# PARADISE COOKIES

**NEW**

- \* PEANUT
- \* CHOCOLATE
- \* CHOCONUT
- \* COCONUT



# PARADISE BAKERY

PARADISE BAKERY GROUP  
MANUFACTURERS OF QUALITY LOCALLY PRODUCED  
PRODUCTS: PARADISE BISCUITS, COOKIES,  
SUNIFIELD BREADS, PASTRIES AND PIES.

# MILK'N'BRAN

## THE HEALTHY NEW BREAD FROM SUNIFIELD



# MILK'N'BRAN

It's just full of natural goodness

At Sunifield, we understand that you want the kind of bread that's best for you and your family.

That's why we've filled new Sunifield Milk'n'Bran with fresh, healthy products, like natural wheat grain fibre, 100% vegetable shortening, wholesome milk

and added bran.

That's also why we've kept Sunifield Milk'n'Bran absolutely free from artificial colouring, and artificial flavouring.

Milk'n'Bran by Sunifield. It's just full of natural goodness.

**Sunifield**  
BREAD

**BY PARADISE,  
THE BEST IN  
QUALITY AND  
FRESHNESS**

PORT MORESBY: KUNAI ST. HOHOLA.  
P.O. BOX 1624 BOROKO. PHONE: 255124

LAE: BUTIBUM RD. TARAKA.  
P.O. BOX 2173 LAE. PHONE: 457177

RABAUL: VULCAN ST. RABAUL.  
P.O. BOX 257 RABAUL. PHONE: 921957

HEB 2063



# GO FOR GAS

**IN JULY 1983 TESTS WERE OF MINERALS AND ENERGY AND KEROSENE AS A COOKING METHOD. THE RESULTS SHOWED THE FOLLOWING:**

**1. COOKING TIME USING GAS CAN BE SUBSTANTIALLY LESS THAN USING ELECTRICITY OR KEROSENE.**

**2. THE COST OF COOKING ON GAS CAN BE NEARLY 50% CHEAPER THAN ELECTRICITY NEARLY 33% CHEAPER THAN KEROSENE.**

**FIREWOOD**



**SCARCE AND COSTLY?**

**ELECTRICITY**

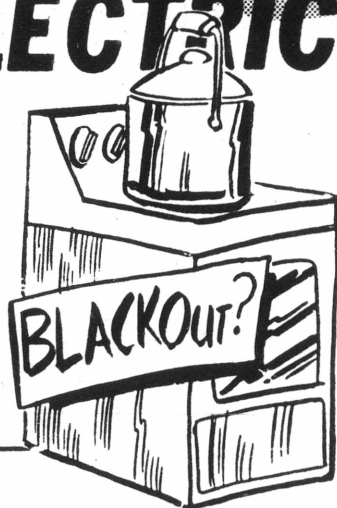

**TOO EXPENSIVE?**

**KEROSENE**



**MESSY, SLOW, GIVES  
SMOKE IN YOUR FOOD**

**To obtain your copy of these results and find out more about the advantages of gas: Write to Boral Gas (PNG) Pty Ltd., Box 1468 Port Moresby. Or Tele:**

# Wantok Wholesale and Tradestore Supplier

## Trading Tips

# Get your orders in

• The first of a monthly series of advice columns for tradestore owners, from "Skul bilong Stuakipa," edited by Eleonore Koeck.

At regular intervals a storekeeper should make purchases to fill up his stock so as to give a good service to his customers. Therefore, before stock runs out completely, the storekeeper has to prepare an

### ORDER FORM

When he places the orders with the different wholesalers, he should check for the cheapest prices.

The order form shows the following information:

\* The name and address of the

business which is buying the goods.

\* A full description of the goods that are being ordered.

\* The quantity of the goods that are required.

\* How the goods should be sent - ship, post or by air.

Each order form can be recognised by a number printed on it. There are two exact copies of each order form:

1. The ORIGINAL, or top copy, is turned out and sent to the supplier. The supplier uses this to

make up the package of goods to be sent to the retailer.

2. The DUPLICATE, or second copy, is kept in the order book of the person making the order. This is a very important copy. It is used by the person receiving the goods to see that he has received the goods which he did order.

Customer, who is ordering the goods.

Name and address of the business from whom the goods are being bought.

Full description of goods being ordered.

Sepik Traders P.O.Box 126 Angoram		ORDER No. 0045'
to: Garamut Enterprise P.O.Box 14, Wewak		Date, 1978 05 12
Please supply the followings: DESCRIPTION		Quantity required
		Price p.unit
Rice 25 kg	10 bales	7.70
Fish 48x15oz.	21 ctn.	14.50
National Tea	1 ctn.	32.00
Sun Salt 20x1kg	5 bales	2.90
Kokonut Bisquit	2 ctn.	7.25
Rice plates 22cm	1 doz.	3.80
T-shirts PNG	2 doz.	7.90
Gillette razor blades	5 cards	6.40
Maxell batteries	1 ctn.	33.00
Signature of person completing order form: <i>John Wanta</i>		

Number to allow the order to be found at some later time.

Date on which the order was made.

Price of each article ordered.

Amount of each item ordered.

## GORDON AND GOTCH (P.N.G.) PTY. LTD.

(INCORPORATED IN PAPUA NEW GUINEA)

**PUBLISHERS: BOOK AND MAGAZINE  
DISTRIBUTORS**

PHONE: 254551,  
254855  
TELEX: PNGGOTCH  
NE22263



P.O. BOX 107,  
BOROKO,  
PAPUA NEW GUINEA

**PAPUA NEW GUINEA BOOKLISTS**

**AVAILABLE ON REQUEST**

Peoples of PNG Series K1.00  
Papua New Guinea Area Books K1.95  
Butterflies of PNG (Wall Freeze) K1.50  
Butterflies OF PNG Greeting Cards pkt 8 K4.50  
PNG Post Cards (Bundle of 50) K10  
PNG Greetings Cards (Bundle of 50) K15  
Dictionaries — PNG Atlases  
PNG Tourist Maps — World Maps

Lady Bird Series K1.40  
P.N.G General Titles  
where there is no doctor  
songs of PNG (with record)  
say it in Motu  
founding of the Roman Catholic Church  
PNG a survival travel kit  
introduction to New Guinea Pidgin



**Wantok Wholesale and Tradestore Supplier**

# Steaming ahead with serving PNG's tradestores

WHEREVER there are Steamships shops throughout Papua New Guinea, there are wholesale services available for all sectors of the food and merchandise market, including tradestore operations.

Tradestore operators can benefit from Steamships' extensive wholesale network throughout the nation said the general manager of Steamships' merchandising division for the New Guinea area, and of Steamships Machinery Jack Bolt.

Mr Bolt said that for tradestore operators in Port Moresby and nearby, Steamships offers a computerised price list of food products in its wholesale store. He said that the computerised price list shows to the trade store operator (and the grocery and supermarket operator) the suggested retail value of the item, and the wholesale price that he buys at.

Mr Bolt said that this then helps the operator set his mark up on the food item that he wishes to sell.

## Computerised

Mr Bolt said, however, that this computerised price list only exists for its Port Moresby wholesale store, and not in other centres.

In addition to food items, Steamships distributes through its wholesale stores non-food items which range through clothes, pots, pans, crockery, torch lights, batteries, radios, cassettes, and many other goods.

One other important service that

Steamships maintains for small business operators in very remote areas is its country order system, Mr Bolt said. He said that such people can place their order at their nearest Steamships wholesale store, and have their orders delivered to them.

However, he said that many trade store operators in the remote areas do not have an arrangement to buy merchandise goods on credit from Steamships.

Mr Bolt said that for such people, Steamships requires that the operator sends a list of what is required to Steamships. The nearest Steamships wholesale store then sends an invoice to the operator of what the items amount to.

## Postal

The trade store operator then sends a postal order or bank draft to the Steamships wholesale store which then has the goods sent out to the operator.

Mr Bolt said, however, that in recent years with improved road transport, there had been a gradual decline in the amount of orders Steamships received for its country order service. But the country order service was still an important part of how Steamships meets the need of the tradestore community.



• Steamies' wholesale warehouse at Waigani Drive, Port Moresby.

★ ★ George Seto & Co.  
★ G'S ★ Pty. Ltd. The Centre  
★ ★ P.O. Box 62  
★ ★ Wewak

## Specialising at

- Wholesaling
- Retailing
- Importing in the East & West Sepik

Tel: 86-2458  
86 2321

Tlx: 86129  
Cables: Wisdom

G'S ★ ★ ★ ★ ★ ★ ★ G'S ★ ★ ★ ★ ★ ★ ★

# Steamies Wholesale



## KRAFT PEANUT BUTTER

Carton  
12 x 200g

Item No's

29058

29071

CRUNCHY  
SMOOTH

11<sup>64</sup>



## KRAFT CHEDDAR CHEESE

Carton  
48 x 250g

Item No

29580

36<sup>28</sup>



## ARNOTTS MILK ARROWROOT

Carton  
20 x 250g

Item No

34860

14<sup>80</sup>



## ARNOTTS GINGER NUT

Carton  
20 x 250g

Item No

34232

15<sup>39</sup>



## COLD POWER DETERGENT

Carton  
48 x 200g

Item No

39659

19<sup>83</sup>



## LIME FRESH BATH SOAP

Carton  
72 x 125g

Item No

47037

26<sup>87</sup>

Stanley Esplanade, Port Moresby, Phone 22 0271, 22 0334.  
Waigani Drive, Phone 25 6895, 25 5202.



# Steamies Wholesale

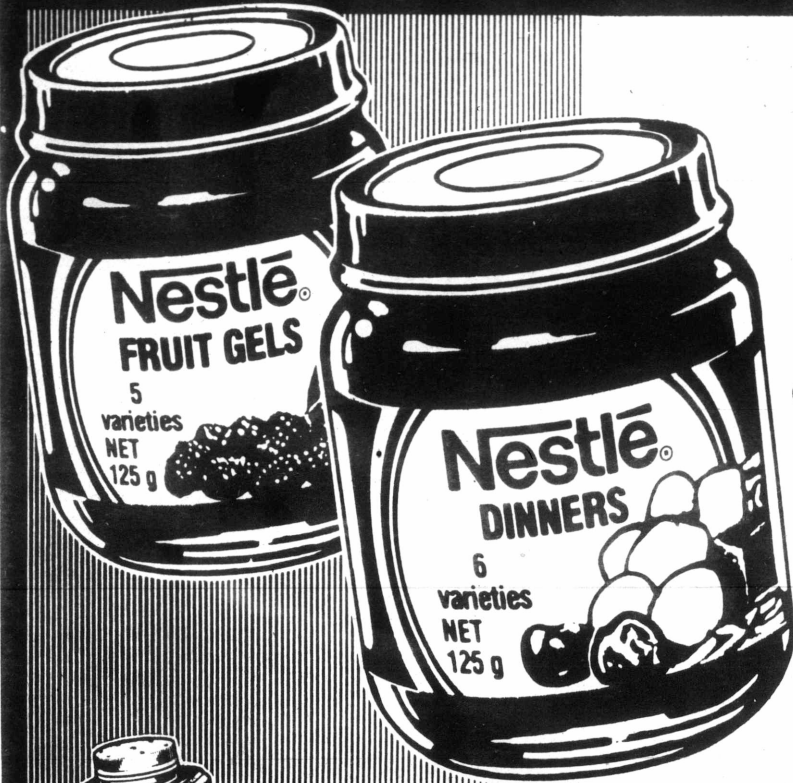

## NESTLE BABY FOOD

Carton  
24 x 125g

Item No's
CHICKEN AND VEGETABLES 16478
EGG CUSTARD 16474
LAMB AND VEGETABLES 16468
BEEF AND VEGETABLES 16470
BLACKCURRANT GEL 22355
PINEAPPLE GEL 22360
MIXED VEGETABLES 16510
CHICKEN BROTH 16515
MANDARIN AND BANANA 16495

**8<sup>60</sup>**



## JOHNSONS BABY POWDER

Carton  
12 x 125g

Item No
51041

**8<sup>26</sup>**



## JOHNSONS BAND-AID PLASTIC STRIPS

Carton  
24 x 24's

Item No
55430

**7<sup>67</sup>**

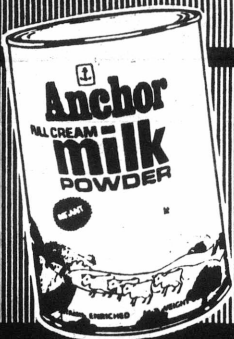

## ANCHOR INSTANT MILK POWDER

Carton  
24 x 400g

Item No
36460

**31<sup>55</sup>**



## ANCHOR PURE CREAMY BUTTER

Carton  
24 x 340g

Item No
29465

**23<sup>63</sup>**

**Freezer  
Special**

## MUTTON LOIN CHOPS

**1<sup>50</sup>**  
per Kg

Stanley Esplanade, Port Moresby, Phone 22 0271, 22 0334.  
Waigani Drive, Phone 25 6895, 25 5202.

# Steamies Wholesale



## CONTINENTAL SOUPS

Carton  
24 x 40g

Item No's

CREAM OF CHICKEN

28850

FRENCH ONION

28694

24 x 65g

HEARTY BEEF BROTH

28889

THICK VEGETABLE

28681

24 x 45g

CHINESE NOODLE

28824

24 x 50g

MUSHROOM

28707

24 x 75g

PEA & HAM

28876

THE  
BIGGEST  
RANGE OF  
PACKET  
SOUPS

10<sup>80</sup>

**HEINZ  
BAKED BEANS  
IN TOMATO**

Carton  
24 x 225g

Item No

46135

7<sup>89</sup>

**HEINZ  
SPAGHETTI  
IN TOMATO**

Carton  
24 x 225g

Item No

46300

7<sup>89</sup>

**MINCE  
BEEF**

1<sup>65</sup>  
per Kg

**Freezer  
Special**

**COPPER KETTLE  
COFFEE**

Carton  
24 x 50g

Item No

16570

21<sup>92</sup>

**TANG ORANGE**

Carton  
15 x 500g

Item No

10995

30<sup>36</sup>

Stanley Esplanade, Port Moresby, Phone 22 0271, 22 0334.  
Waigani Drive, Phone 25 6895, 25 5202.



# Steamies Wholesale



## GOLDEN CIRCLE PINEAPPLE

Carton  
24 x 225g

SLICED  
PIECES  
(UNSWEETENED)

Item No's
11995
12155

K8.65

**8<sup>30</sup>**



## FLAME PLAIN FLOUR

Carton  
1 x 5kg

Item No
22150

**2<sup>05</sup>**

## FLAME PLAIN FLOUR

Carton  
1 x 10kg

Item No
22145

**3<sup>80</sup>**



## GREATWALL CORNED BEEF

Carton  
48 x 340g

Item No
36310

**36<sup>23</sup>**



## MALING ROASTED DUCK

Carton  
48 x 250g

Item No
26343

**44<sup>97</sup>**



## MALING CURRIED CHICKEN

Carton  
48 x 312g

Item No
26345

**32<sup>45</sup>**

Stanley Esplanade, Port Moresby, Phone 22 0271, 22 0334.

Waigani Drive, Phone 25 6895, 25 5202.

**Wantok Wholesale and Tradestore Supplier**

# Rot bilong kisim kago

OL samting long stua bilong yu i sot liklik o? No ken wetim ol samting pinis olgeta na bihain tasol yu go baim nupela gen. Nogat.

Hariap na baim ol nupela samting NAU! Kisim wanpela pepa bilong odaim kago na raitim olgeta samting yu laikim. Bihain yu pinis, orait, salim i go

long wanpela bakstua.

Yu mas skelim ol prais long wan wan bakstua pastaim. orait, nau odaim kago bilong yu long wanem bakstua i no dia tumas.

Wanem Kain Toktok I Stap Long Oda Pepa?

\* Namba wan, em i nem na

adres bilong husat man o bisnis i odaim kago.

\* Namba tu, oda pepa i soim klia tru, wanem samting dispela man o bisnis i laik odaim.

\* Namba tri, em i soim hamas samting tru, man o bisnis i bin odaim.

\* Namba foa, em i tokim bakstua longwe bilong salim

kago: Long sip, o balus o long trak.

Sapos wanpela rong i kamap bihain, orait ol i ken painim oda pepa hariap tru. Long wanem, olgeta oda pepa i gat namba. Na taim yumi raitim oda, bai pepa aninit tu i gat rait mak long en. Orait, dispela pepa yu raitim

long en ya, yu mas salim i go long bakstua. Man i ranim bakstua ya em bai holim, na em bai salim ol samting i kam long yu.

Na dispela pepa aninit i gat rait mak bilong oda yu bin mekim ya, yu yet mas holim i stap.

• *Pepa bilong odaim kago i luk olsem:*

Husat i odaim kago →	Sepik Traders, P.O. Box 126, ANGORAM.	Oda namba 0045	Namba bilong oda
Nem bilong ol samting na hamas ol i odaim	Dispela oda i go long: Garamut Enterprises, P.O. Box 14, WEWAK	De: 12/5/79	
Oda bai go long wanem bakstua →	Mi laik odaim ol dispela samting:	Hamas	Prais bilong wan wan
	Rais - 25 kilo	10 bek	K 7.70
	Katen tin pis 48 x 15 auns	21 katen	K14.50
	Nesnel ti	1 katen	K32.00
	San sol (salt)	5 bek	K 2.90
	Kokonas bisket	2 katen	K 7.25
	T - Siot (PNG)	2 dasen - 24	K 7.90
	Gillette resa	5 bokis	K 6.40
	Mak bilong husat man i odaim kago:		
			Prais bilong ol wanpela wanpela samting
			Hamas samting olgeta.

• *Dispela helpim i kam long wanpela buk Skul bilong Stuakipa i wokim long Wewak.*



## KES HOLDINGS PTY LTD

**IMPORTED  
ONION AND FRESH  
FRUIT**

# FRESH

**LOCALLY  
GROWN POTATOES AND  
VEGETABLES**

**LARGE VARIETY  
WHOLESALE  
PRICES**

**MOROBÉ AVE LAE  
P.O. BOX 633**

**PHONE 42 3440**

**42 2738**

**42 2415**

**TELEX STOCK 44 136**

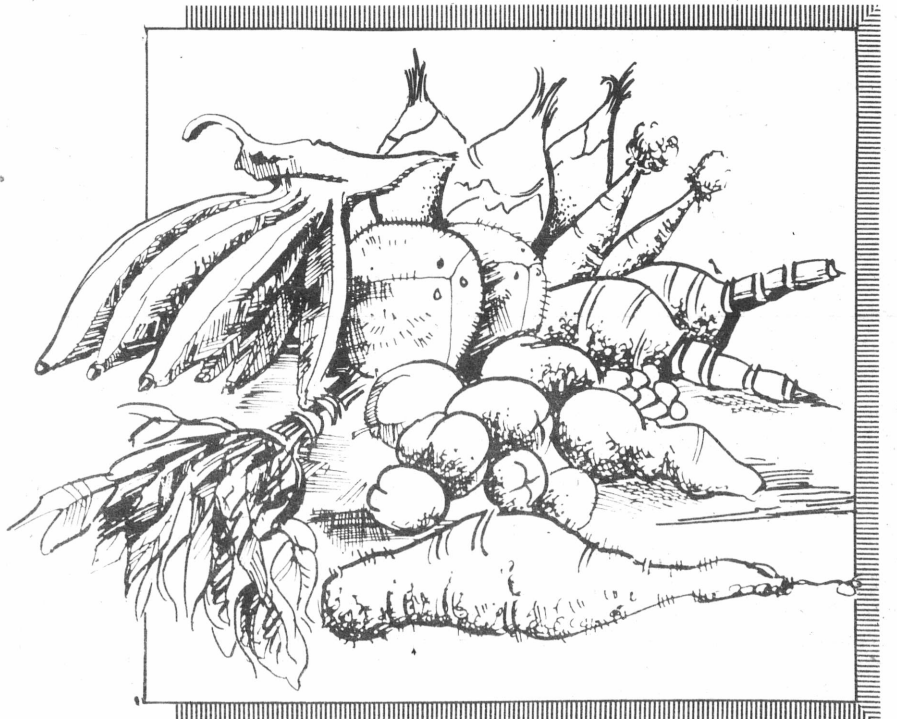



# BOOKS

## THE FASTEST GROWING MARKET IN THE COUNTRY

WE ARE SUPPLIERS OF BOOKS FOR AN  
AGE RANGE OF 3 — 50.

WE SPECIALISE IN CHILDREN'S BOOKS.

WE ARE ALSO SUPPLIERS OF ALL TYPES OF  
ACTIVITY BOOKS, FOR EXAMPLE, COLOURING  
BOOKS, SEARCH A WORD, PUZZLES, PAINTING  
AND MANY, MANY, MORE.

IF YOU DO NOT ALREADY STOCK BOOKS HAVE YOU THOUGHT OF  
TRYING?

1. DO YOU HAVE SCHOOL CHILDREN VISITING YOUR STORE?
2. DO THEY HAVE 50 TOEA OR MORE TO SPEND?
3. DO YOU HAVE A SCHOOL NEAR YOU?
4. HOW MANY CHILDREN NEAR YOU ATTEND HIGH SCHOOL?

**THEY NEED BOOKS TO  
HELP THEM DO BETTER AT  
SCHOOL.**

BY SELLING BOOKS YOU WILL BE HELPING THE  
PEOPLE IN YOUR COMMUNITY.

FOR A COPY OF OUR CATALOGUE AND ORDER  
FORM PLEASE CONTACT:

LESLEY BRENNAN,  
WEB BOOKS  
P.O. BOX 1385,  
PORT MORESBY, NCD

OR TELEPHONE: 25 2214

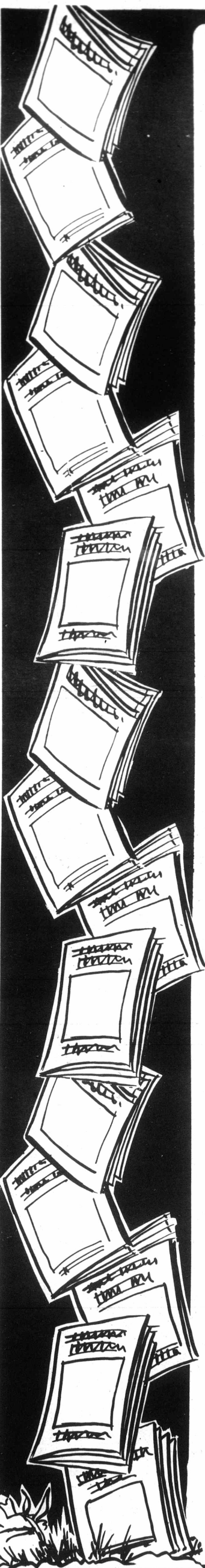

**Wantok Wholesale and Tradestore Supplier**

# Cheques and balances

- From Gary Bondfield in The Age.

**THE accounting concept of control involves accuracy and efficiency in recording and reporting as well as the security and good management of assets.**

Thus the basic accounting operations contain many balances and checks.

Many accounting students see most of the balances in ledger accounts, where the ledger balances must be thought of in three ways.

First, a balance at the start of an accounting period must be for an asset, liability, or proprietorship amount, that continues through the divisions of accounting periods. Income and expense amounts are for one period only and are closed each period to the trading or profit and loss accounts.

Second, a balance represents an imbalance in the two sides of a ledger account: a balance in a "T" ledger account is placed on the lesser side of that account, then brought down.

## Ledger

Finally, the word "balance" refers to an amount or value of, for example, money in the bank account, money owed to creditors, or the value of vehicles the business owns.

The balance in ledger accounts at the start of a period come from those asset, liability, or proprietorship accounts, from the previous period, which also are recorded in the last period's balance sheet.

The balance at the end of this period goes to this period's trial balance, then to the profit and loss report or the balance sheet.

The trial balance is a list of all the ledger accounts and their balances arranged in the appropriate debit or credit column. The two columns are totalled simply as a check.

If the totals are not equal, usually there is an account left out, or an error with the transfer of figures, or a mistake in addition.

In a trial balance that balances, it is still possible for errors to exist, as transactions may

have been omitted from the journals and ledger, or the same recording mistakes been made twice.

The balance sheet also should have equal totals: that is a check on the accuracy of the final reports.

## Journal

This article started with control and the ledger, but before the ledger most businesses use journals to record the transactions as they occur (and some use a cash book).

When the two main, and largest, journals - the cash receipts journal and the cash payments journal - are completed, the bank column total (arrived at by adding "down" the column) should equal the sum of the cash columns (by adding "across" the journal).

If a cash book is used instead of these journals, a check similar can be carried out, provided the opening and closing bank balances are left out.

That is the basic system; but there is more to accounting than these bookkeeping functions. A very important check

occurs when the figures for an accounting period are compared with the budgets (what the business planned to achieve during the time).

The differences or variances between actual results and the relevant budget (eg, the profit and loss report to the budgeted profit and loss report), should be calculated and some questions should be asked.

How well did the business go for the period? Where did the firm exceed the plans? Where was it below the plans? Can these differences be explained satisfactorily? Is there a problem area to receive tighter control?

If the income differs significantly from the planned level either higher or lower, the variable expenses in the profit budget should be adjusted first, then the questions asked.

## Return

Is the business making a satisfactory return for the owner? How does the profit, in amount, and as a percentage of the owner's investment, compare with returns on investing, previous years

for this business, other similar businesses (in type and size), and even other businesses it is feasible for the owner to be involved in?

If the business has subsidiary accounting records, a check occurs into the general ledger from each subsidiary area. If there is a debtors' ledger, the balance of each debtor's account is placed with others in a table or schedule (as accountants call a list of names with figures).

The total of that schedule should equal the debtors' account balance in the general ledger (a schedule for all individual debtors should equal one account for all the debtors).

This also should be the case for creditors, and for any area in which a subsidiary system operates, including expenses and assets such as stock and vehicles.

The subsidiary accounting system may involve ledgers other than the main one (these usually are done for debtors and creditors), but for stock there probably will be a stock card file, with a stock card for each of the many

items of stock.

For fixed assets, such as vehicles or machines there may be a file of cards or a book of records.

In all cases with

subsidiary records a check should be made to the control account for the item in the general ledger. Debtors' and creditors' ledger.

# Tell the trade of your new products

- DO you have any new products being launched in PNG?
- DO you want the trade to know about your products?
- THIS is the ONLY medium in PNG to reach all wholesalers including tall trade stores, restaurants, hotels, canteens, schools, hospitals, fast food outlets.
- CALL us on 25 2500.

# YOUR BILUM CARRIES MORE FROM STRET PASIN STOA A PNG DEVELOPMENT BANK PROJECT

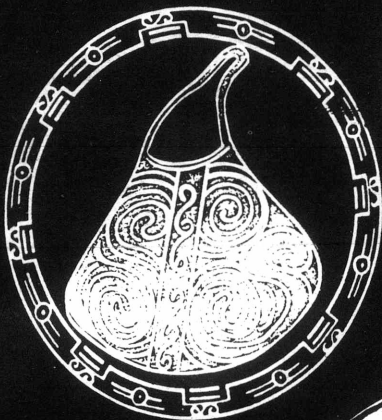

Pikinini bilong mi i save kraim i laik kisim sampela kaikai. No-waris bilum carries more from Stret Pasin Stoa.

Mama bilong wanem yu no baim Sparka Punch!

75 STORES Nationwide!





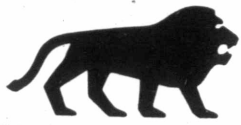

**LEONARD**

# Refrigerators and Freezers

## THE NAME YOU CAN TRUST

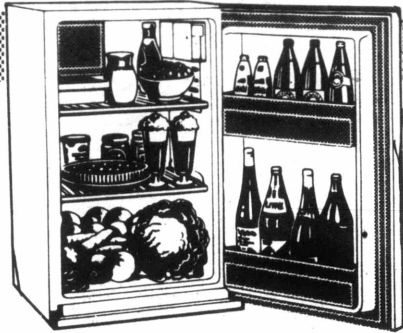

### LC 110 110 LITRE COMPACT REFRIGERATOR

*The ideal second refrigerator to fit just about anywhere.*

- Push button defrost • Adjustable shelves • Spacious ice box • Tall bottle storage • Ice trays.

### LC 320 320 LITRE REFRIGERATOR/FREEZER

*The family refrigerator, particularly suitable in areas where there is a height restriction.*

- Automatic defrost • Egg bin • Butter conditioner • Tall bottle storage • Twin dairy compartments • Ice trays • Vegetable and fruit crisper • Ice bin • Full width vegetable basket.

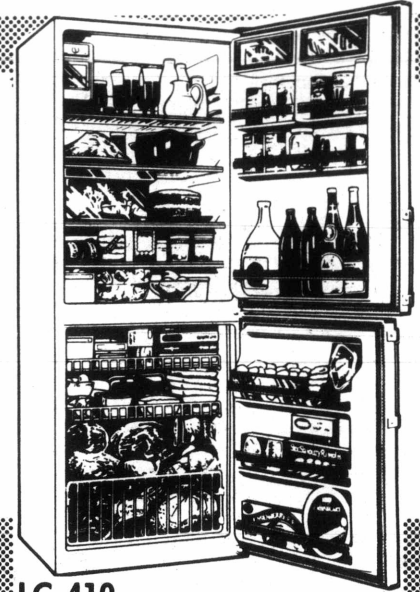

### LC 410 410 LITRE REFRIGERATOR/FREEZER

*The big family refrigerator and freezer combined to save you space.*

- Large 168 litre freezer • Egg bin • Automatic defrost\* • Ice trays • Butter conditioner • Ice bin • Twin dairy compartments • Tall bottle storage • Vegetable and fruit crisper.



### LC 370 370 LITRE REFRIGERATOR/FREEZER

*The two door with big refrigerator capacity.*

- Automatic defrost\* • Tall bottle storage • Butter conditioner • Ice trays • Twin dairy compartments • Ice bin • Vegetable and fruit crisper • Egg bin • Full width vegetable basket.

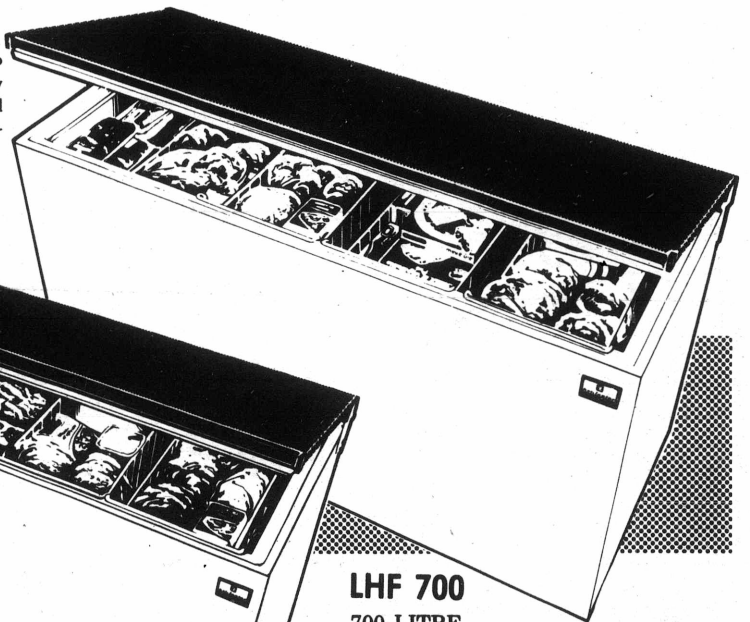

### LHF 700 700 LITRE CHEST FREEZER

- Food storage guide • Safety light to show that power is on and temperature is correct • 3 removable storage baskets • 1 slide-along divider rack • Woodgrain worktop • Fast freezing shelf

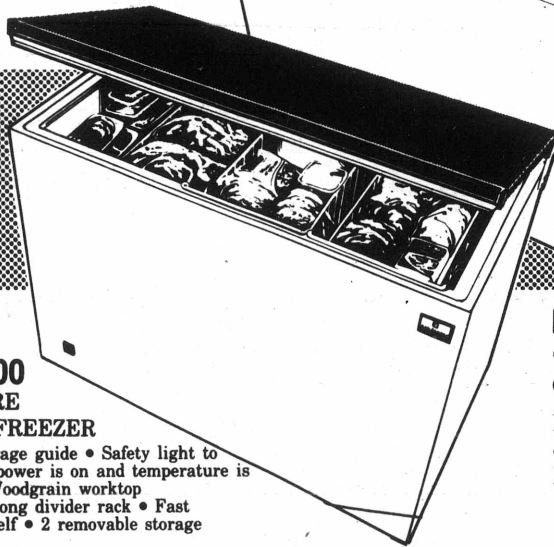

### LHF 500 500 LITRE CHEST FREEZER

- Food storage guide • Safety light to show that power is on and temperature is correct • Woodgrain worktop • 1 slide-along divider rack • Fast freezing shelf • 2 removable storage baskets

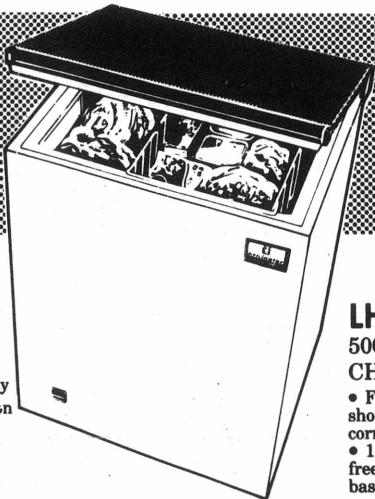

### LHF 200 200 LITRE CHEST FREEZER

- Food storage guide • Removable storage basket • Fast freezing shelf • Safety light to show that power is on and temperature is correct • Woodgrain worktop.



# Carpenters New Guinea

PORT MORESBY 25 3700 LAE 42 4000 MADANG 82 2077 GOROKA 73 1716  
RABAU 92 1543 MT. HAGEN 52 1600

SCOTT



# CHEF Gas Cookers

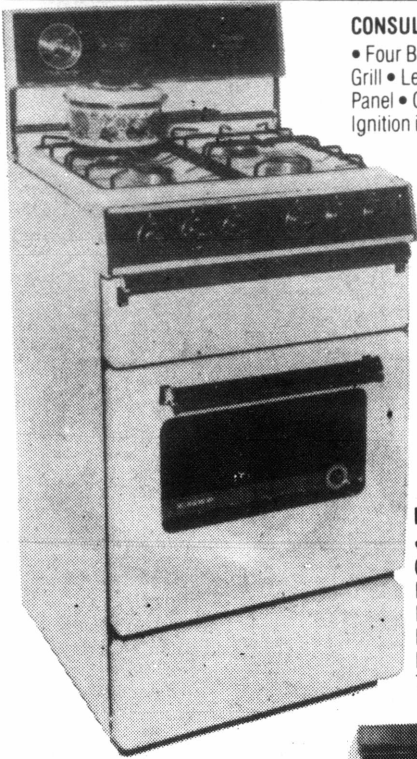

#### CONSUL - GCI

- Four Burners • Infra-Ray Grill • Leather Grain Trim on Control Panel • One Hour Ringer Timer • Piezo Ignition in Oven.

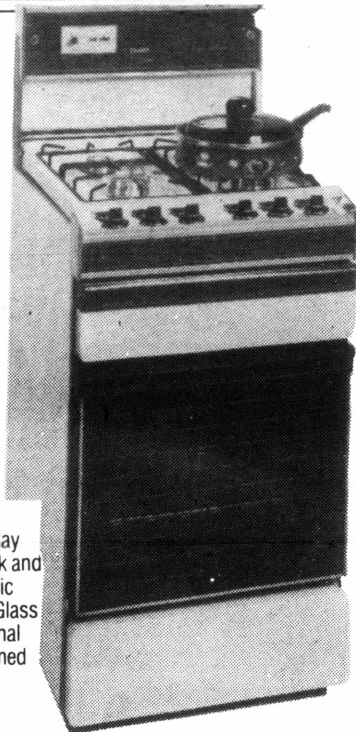

#### REGAL - GRBZ

- Four Burners • Large Infra-Ray Grill • Digital Time-of-Day Clock and Minute Minder • Chef Electronic Ignition to all Burners • Black Glass Door • Storage Drawer • Optional Extras - Rotisserie - Programmed Timed Oven - Strip Light.



#### MAJESTIC - GMI

- Four Hotplate Burners • Non-Automatic • Piezo Ignition in Oven • One Hour Timer • White Glass Oven Door • Storage Drawer • Leather Grain Trim on Splashback and Control Panel.

#### CONTESSA - GCOZ

- Four Hotplate Burners • Digital Time-of-Day Clock and Minute Minder • Wider Oven • Top Party Oven for Warming and Low Temperature Cooking • Black Glass Oven Doors • Large Infra-Ray Grill • Chef Electronic Ignition to all Burners • Hotplate Light and Oven Lights • Storage Drawer • Rotisserie with Side Vegetable Trays • Optional extra - Programme Timed Oven.

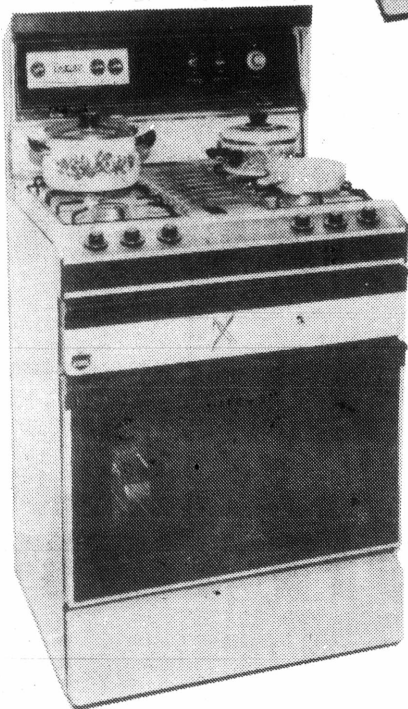

#### FAMILY - GFI

- Four Hotplate Burners • Large Infra-Ray Grill • One Hour Ringer Timer • Leather Grain Trim On Control Panel • Large Glass Oven Door • Storage Drawer • Chef Electronic Ignition.



*Available at:*

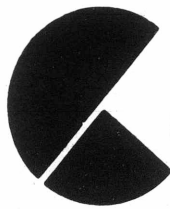

## Carpenters New Guinea

PORT MORESBY 25 3700 LAE 42 4000 MADANG 82 2077  
GOROKA 73 1716 RABAU 92 1543 MT. HAGEN 52 1600

**YOUR KINA BUYS  
MORE AT A  
CARPENTERS  
STORE**



# HIGHLAND RAISED



- **FARM FRESH**
- **FROZEN CHICKENS  
& PIECES**
- **AND FRESH FARM  
EGGS**



**HIGHLAND PRODUCTS PTY LTD. ZENANG**

**423440/422415 - SALES  
423900 - DESPATCH  
445373 - FARM**

**Wantok Wholesale and Tradestore Supplier**

# Ever ready to join PNG's battle of the batteries

THE Eveready Battery is the world's largest selling battery. There are 14 large factories in the world, which produce and distribute the batteries.

Some factories are in South-east Asia and Australia.

At home in Papua New Guinea, Eveready Batteries are now being heavily promoted the shelves in big shops, hardware and tradestores.

The largest distributor of Eveready Batteries in the country, Burns Philp began its campaign with the product approximately three weeks ago.

## Delighted

Burns Philp's national controller (electrical), Bernard Warneken, explains, "BP is delighted to tell the public that we are selling the best product on the PNG market, where batteries are concerned."

Mr Warneken said it had been proven by various independent tests, that Eveready Batteries were three per cent more efficient than any other battery brand on sale in PNG.

Eveready Batteries are product from Union Carbide, an American company with a Hong Kong base.

Burns Philp gets its Eveready products from Singapore, from

the largest Eveready Battery plant in the world.

Eveready's biggest competition comes from National now sold exclusively by Chin H Meen - and soon, from a PNG based battery producer with Danich company Hellsens as a major partner.

Burns Philp also supplies Eveready sales support items such as "T" shirts and caps. The company has recently spent K30,000 on advertising Eveready products, especially batteries.

Mr Warneken said, "We are the only people who bring in the full range of Eveready Batteries - four different sizes in two different packs. We have the Super Heavy Duty battery, transistor and lantern batteries, and those for general purpose.

## Quality

"We know of five other brands of batteries which are selling now, which offer less in quality and range, but I don't think it's necessary to say what they are."

On April, 4 and 6, BP held Eveready Battery awareness and



• The Eveready sales promotion team with Eveready bus behind.

promotion campaigns in Lae, Rabaul and Port Moresby. The company now sells Eveready Batteries in Kavieng, Rabaul, Kieta, Lae, Popondetta, Goroka, Mt Hagen, Madang,

Wewak, Kiunga, and Port Moresby.

Mr Werneken said, "Our stock is fresh. We have 14 days to turn over old batteries to Singapore and get new ones. So

what we sell in our own shops and provide to other retail shops is brand new. These new batteries come straight from our distributor, the Union Carbide factory in Singapore."

## Star Choices.



DOUBLE VISION BAND



JOHN WONG — "SOLO IN THE VOLCANO"

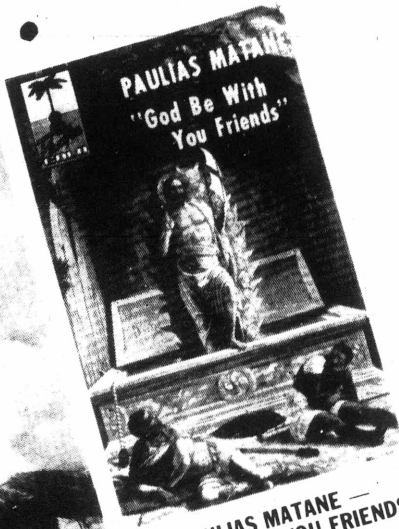

PAULIAS MATANE — "GOD BE WITH YOU FRIENDS"



AGAPE GOSPEL SINGERS OF NEW IRELAND "WE SING FOR CHRIST"

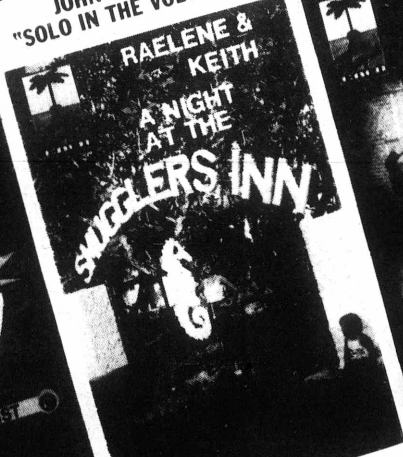

RAELENE & KEITH — "A NIGHT AT THE SMUGGLERS INN"

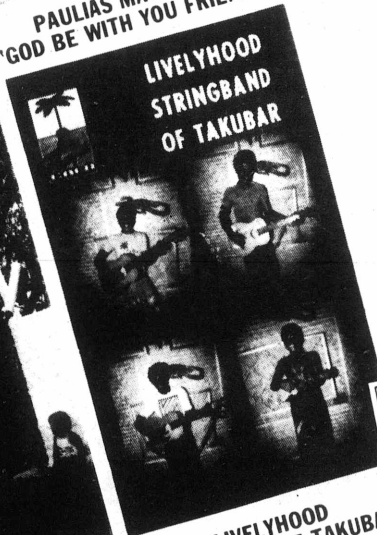

LIVELYHOOD STRINGBAND OF TAKUBAR



## Pacific Gold Studios

### LATEST RELEASES

TRADE ENQUIRIES

PH: 25-1294  
P.O. BOX 5999, BOROKE

PH: 42-1639  
P.O. BOX 2596, LAE

PH: 92-1639  
P.O. BOX 29, RABAUL





**PAPUA NEW GUINEA  
COFFEE INDUSTRY BOARD**

**PNG IS A COFFEE COUNTRY MAKE IT YOUR  
TRADITION BY — DRINKING YOUR OWN HOME  
GROWN FRESH, HIGH QUALITY COFFEE**

**"PNG COFFEE"**

**ASK OUR SEVEN ROASTERS  
FOR THEIR FRESH BLENDS:-**

---

**GOROKA COFFEE PRODUCERS LIMITED  
P.O. BOX 555, GOROKA. EHP.**

---

**W.R. CARPENTERS & CO. ESTATES  
P.O. BOX 94 MOUNT HAGEN. WHP.**

---

**B.R. HEAGNERY PTY LTD  
P.O. BOX 127 MOUNT HAGEN. WHP.**

---

**NAMASU COFFEE PTY LTD  
P.O. BOX 615 LAE. MP.**

---

**KORONA PTY LTD  
P.O. BOX 22 LAE. MP.**

---

**WAHGI MEK PLANTATIONS PTY LTD  
P.O. BOX 29 BANZ. WHP.**

---

**HARRISON & CROSFIELD (PNG) LTD  
P.O. BOX 586 LAE. MP.**

---

**P.O. Box 137, GOROKA, Eastern Highlands Province**

**Phone: 72-1266/72-1207**



# Wholesale Orders?



# Andersons make it easier.

Call Rabaul 92 2083 or Lae 42 3991

AF 02A P/WORKSHOP

**Attention all stores!**

# FREE!

*Promotional items*

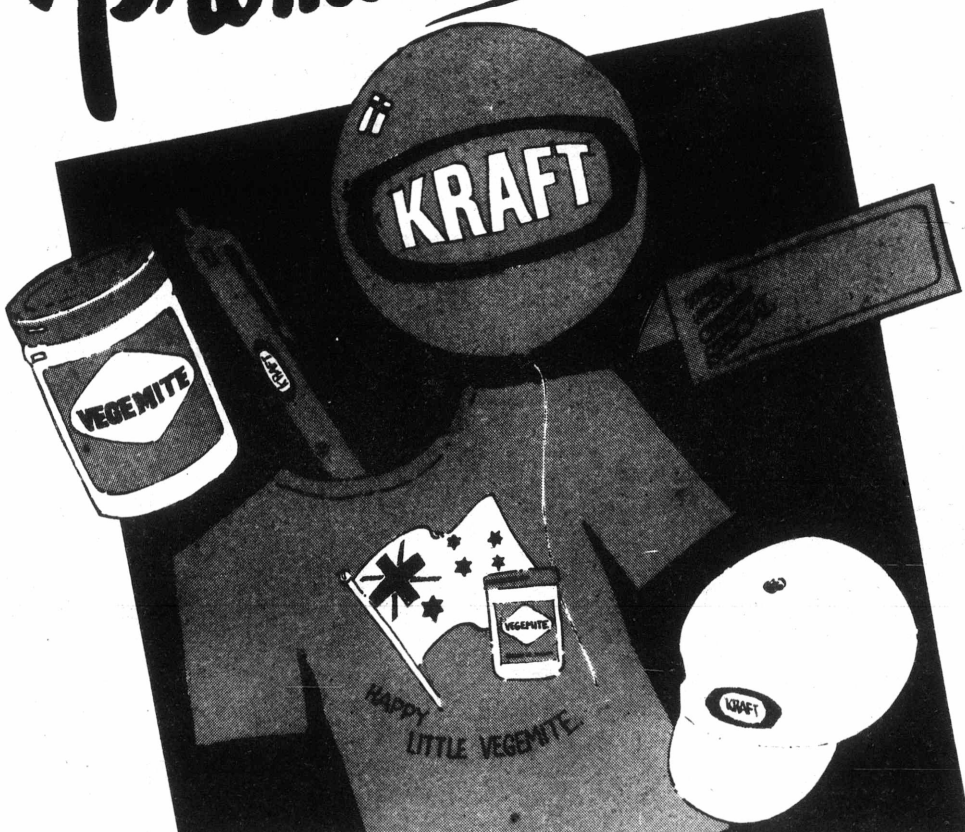

**Increase your sales by giving away kraft balloons, ball pens, T-shirts, caps, glasses and coupons.**

Write or call for your FREE Promotional Items now!

AVAILABLE FROM:  CONSUMER SALES & MARKETING • PH: 213885 • P.O. BOX 378 PORT MORESBY





# Meal Maker Chicken Portions

**Buy a bag of chicken – use some and save some for later!**

Try the new international method of buying chicken. Niugini Table Birds individually freeze and package only the best quality chicken pieces; breasts, thighs and legs, for your table. Buy either of the economical 1 or 2kg carry packs and you'll be surprised at the savings you'll make. Keep them handy in your refrigerator, and use the pieces as you need them —

for casseroles,  
lunches or  
dinners.

Available NOW at  
SUPERMARKETS  
& TRADE STORES



**NIUGINI  
TABLE BIRDS**



*Share the  
Taste of Goodness*





# FENA FLAVOUR

# BISCUITS!



# Arrow

ARROW BAKING CO.  
TELEPHONE 255266  
OR 256128  
P.O. BOX, 164  
PORT MORESBY





# I'M KOOL

Smoke Kool, the No.1 menthol cigarette  
in Papua New Guinea.



M&C WNG 2732

If undelivered, please return to: Wantok Wholesale and Tradestore Suppliers, Box 1982, Boroko

Printed and published by Rowan Sidney Callick, of Winter street,  
Granville, at Allotment 2, Section 209, Hohola.



# Wantok Rugby League Pullout

## PNG's Stand At The Oceania-France Match

**THE switching of champion half Steven Mortimer to the wing and the world's best lock Ray Price to hooker emphasised just what a one-sided farce the historic Oceania-Europe clash developed into.**

By **TONY DURKIN** on tour with British Airways

The Oceania side romped in 54-4 on a second-rate suburban dust bowl, putting the shudders through Australian officials and fans who will soon host the English Test side during a three-Test series.

The score showed the huge gap in the standard of the game between the northern and southern hemispheres and the Poms desperately need to show more in the coming Tests.

In their defence, at least they will not have to play beside the French. The Europeans had no cohesion and virtually showed no understanding in defence or attack.

The score suggests the match was a fizzer. The Europeans virtually caved in during the second half as the visitors literally took turns at scoring tries and taking conversion attempts.

And coach Graham Lowe pampered his players' whims with positional changes including Mortimer to the wing, Price to hooker, Gene Miles to lock and Wayne Pearce to tight-head prop.

Add to that a pitiful crowd of about 2000 and the disgraceful playing surface — which would not be seen at a country showground after three-years of drought — and those not at the match could be forgiven for thinking the entire promotion was a giant flop.

But there were pluses, and quite a few of them. The game was beamed live on local television to an estimated audience of five million and the Oceania players treated the crowd of dyed-in-the-wool French supporters to some champagne football.

Australian Rugby League chairman, Ken Arthurson, described the match as a truly worthwhile effort in public relations.

"The idea was to boost the game in France, and I am sure that has been achieved today", he said.

Arthurson made special mention of the two Papua New Guinea representatives in the side, David Noifa and Ekon Togili.

"The way the other players reacted when

those two boys did well typifies just what a match like this means to Rugby League," he said.

One sour point of the match was the injury to star centre Mal Meninga. He tore a muscle in his right leg and left the field eight minutes before halftime.

Meninga was limping after the match, but doesn't expect to be sidelined for more than a fortnight.

There was not a bad player in the Oceania side, as the score would suggest. Both backs and forwards worked willingly in attack and defence, combining as though they had been together for months.

But prop Brad Tessmann, a late inclusion for Craig Young, stood out.

Apart from Tessmann, skipper and five-eighth Wally Lewis and forwards Ray Price, Mark Graham and Wayne Pearce were the best for Oceania. Pearce fittingly won the man-of-the-match award for a non-stop effort.

Lewis was remarkable at five-eighth, getting rid of the ball from simply impossible positions to eager supports. It was a though he had no intentions of being tackled on the gravel surface.

Tessmann opened

the scoring in the ninth minute after a bungle from dummy half, close to the European line. The pass went astray and the prop, skirting around behind the ruck, picked up the loose ball and beat some flimsy defence to score under the posts.

In the 15th minute, Lewis produced some of his magic to set up the second try, scored by Kiwi fullback Robin Alfield. Lewis made a break, followed by a strong run and when cornered, threw an overhead pass to the fullback.

Meninga's conversion attempt, from wide out, just missed. Oceania 10-0.

Europe were next to score, and it was a brilliant solo effort by the talented Hanley which brought up their only points of the match. From an orthodox backline move, Hanley stepped through a gap, brushed aside Tessmann then pointlessly beat fullback Alfield to score in the corner.

Again, the conversion was astray. Oceania 10-4.

This try seemed to stir the visitors, who quickly hit back with a try, Tessmann's second, just four minutes later. The prop made the initial bust and then unloaded to the ever-alert hooker, Howie Tamati, who



Ekon Togili and David Noifa did very well in the Oceania Rugby league side.

was pulled down just inside the quarter. Tessmann, backing up, went from dummy half, ran 15 metres, took two defenders with him and scored beside the posts.

With Meninga off the field, Lewis took over the goalkicking, but missed a sitter. Oceania 14-4.

One minute from the break, came the try of the match. Meninga's replacement, PNG winger David Noifa, started to move with an elusive 40-metre run from well inside his own half after retrieving a kick.

From the play the ball, big centre Gene Miles sent a perfect pass to the flying Pearce who put winger Dean Bell away. When cornered, Bell floated a long pass back inside the posts.

Now it was Tessmann's turn to add the extras, but he too missed a sitter. Oceania 18-4, at halftime.

After just five minutes of the second half, it was obvious the Europeans were going to be swamped when Alfield, Boustead and Mortimer combined. Alfield fielded a kick, beat two defenders, linked up with Boustead, now playing in the centres, who sent Mortimer over under the posts.

Hooker Tamati converted, Oceania 24-4.

Queenslanders Lewis, Miles and Boustead combined for the next try, in the 55th minute. Lewis put Miles into a gap with a superb delayed pass and the big centre drew the final line and sent Boustead over under the posts.

And almost before the crowd could blink, the flyer converted his own try, using the left foot. Oceania 30-4.

Seven minutes later Mark Graham crossed under the posts, simply by walking through paper-thin defence. And one of the biggest cheers of the day went up when PNG forward Ekon Togili converted. Oceania 36-4.

From the kick off, which had not varied once from Europe in the entire match to this stage, Graham and fellow Kiwi McGahan combined to humble the home team.

McGahan leapt high to take the short kick-off, and found himself almost in open spaces. When caught by the cover, he found Graham backing up inside and off-loaded to him. Graham in turn was cornered, but his inside pass found McGahan who raced over between the posts.

Kevin Tamati took this conversion attempt and like his cousin, was successful. Oceania 42-4.

McGahan was next to score, in the 68th minute, when he ran 30 metres after taking an intercept. The wide-angled conversion attempt from David Noifa was astray. Oceania 46-4.

Gene Miles scored the next try, a solo effort, six minutes from fulltime, but Mortimer missed the conversion, despite the style and finesse of Mick Cronin. Oceania 50-4.

The boys from PNG settled the dust at the ground with the final try, two minutes from the end. It was scored by Ekon Togili, but the ball passed through at least 10 pairs of hands before the stocky second-rower went over midway between the uprights and touch.

Gene Miles maintained his kick was good, but both judges ruled it wild. Oceania 54-4.

# The Man Behind East

Benny Bogg

BEFORE anyone can start coaching any game, one must know his individual players potentials, weaknesses and how the individual players can improve. The intending coach must understand individuals as players and the players must know that you are their coach. This is the firm belief of the man behind East, Nelson Passingan.

Nelson Passingan, 36 from Umbukul Village in New Hanover is currently East's Rugby League Club Coach in Port Moresby. But many people will know him as a Paga veteran, player and coach.

"Before I took on Easts, I had to study who my boys were. I looked at their physical and mental capabilities and also their approach to the code of Rugby League.

"I believe I did well, because Easts came from nowhere to take on

Brothers in the Kool Cup Challenge. I always emphasise that my players are the best. I picked out of the 100 members of the club, 20 who represented East in the Kool Cup competition.

"The tactic we employed during the Easter break was as such - when we attack, we rip the defence of the opponents, so that they become an attacking mob. This allowed us space to break in for our tries.

"I was very disappointed when we lost to Brothers last Monday, but more than that I was pleased that we went to the finals. We failed to be winners because we never lend a solid tackle." Mr Passingan said.

Nelson Passingan started his sporting career as a soccer player. He played for Rangers Club in Port Moresby in 1969, when he was a young lad working with the Public Works Department.

In 1970 he switched over to GFC. But in 1971

Passingan together with Leo Pokotau and Moso Saleu, formed the Works & Supply or Public Works Team. He was a good striker and in every game he would score up to 6 goals.

In 1971, when a soccer team was selected to go to the 4th South Pacific Games in Tahiti, Passingan missed out in the final selection. And soon after he quit playing soccer.

That same year he joined the Paga Hill Rugby League Club, through a friend, Andrew Nema, a long time Paga Hill player. In his first game in "C" grade Passingan scored 6 tries. In his first game in "Reserve" grade he scored 3 tries. On the same day he plays in the "A" grade and scored two tries under the posts.

Passingan played for Paga "A" grade until 1974.

Recalling those days Passingan said, "In those days, the whiteman ran the club."

When Tony Lavutul

became president of Paga Hill in 1974, Passingan assisted in coaching. In 1975 he became Paga's President and coach. Passingan went back to playing again, though this time in the "C" grade and the "Reserve" grade because of work commitment.

He was only 25, and already a coach and president of a big rugby league club. Maybe the youngest too. In that year (1975) he took Paga into victory as first premiers of Port Moresby and that was after 8 years of carrying the sick title "Wodden Spooners."

Passingan also took Paga (Port Moresby) to Lac in 1975 and won the Cambridge Cup title from Mt Hagen Brothers.

In 1978, he was transferred to Mt Hagen where he was then appointed coach of Mt Hagen Brothers. That year rugby fans saw his team walk over Wests of Port Moresby and the Cambridge Cup competition in Lac.



Passingan - The man behind Easts.

In that year Nelson Passingan was elected by Highlands zone Rugby League, to be the trainer of the zone. "We won by defeating Southern Zone. Uwe Sabume was the coach."

In 1980, he was elected Mt Hagen Coach, to coach the side at the Highlands Zone Selection competition.

In 1982, Nelson Passingan was selected by PNGRFL to be the first ever PNG trainer for the Presidents 13. Uwe Sabume was the coach.

"Thinking back, I have a level one certificate in coaching Rugby League, which I obtained in Australia in 1977."

"Passingan was appointed the public relation officer for the touring British side, by

the PNGRFL in 1982.

"From my experience behind me, I still believe that there is a lot to learn before you can call yourself a coach. PNG has a lot of talented players. So whatever a coach does, he must read well his individual player in order to reap the best results from his team.

"To be a coach, one should be a committed member to his club or team.

"Back to my own club, Easts, I am working on discipline and still trying to learn more about individuals. At the end of the second round and before the finals, if Easts listen to me, we will not be on the bottom of the ladder. We will be running for the title."



# the RETURN

OF

*Rugby league*

**NEWS**



**In Wantok niuspepa weekly...  
1st Appearance 3rd May**

# Community Corner Tools for Teachers



Last week we learned how to make an electromagnet and an electric buzzer. This week we are going to look at the uses of electromagnets.

If your buzzer does not work:

1. Test the batteries to see that they are not flat (will they light a lamp?).
2. Check all the connections (joints) in the buzzer.
3. Make sure that the end of the electromagnet is close to the vibrator. If it is touching the vibrator, it will not work.
4. Check to see that the contact is touching the vibrator when you start. The buzzer makes a buzzing sound as electricity travels through the circuit.

## USES OF ELECTROMAGNETS

### A. The Car Horn

It consists of a piece of iron which is bolted in the centre of a circle of thin metal. The piece of iron can vibrate up and down like a drum as the circle of metal is bolted down at its edges. So if the iron vibrates, a sound is produced.

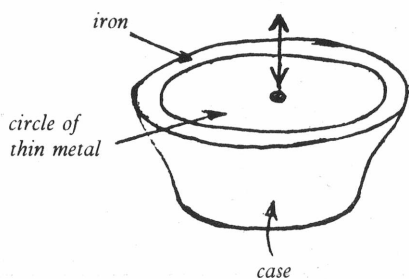

This is how the sound of a car horn is made. Now let us learn how an electromagnet makes the iron move up and down.

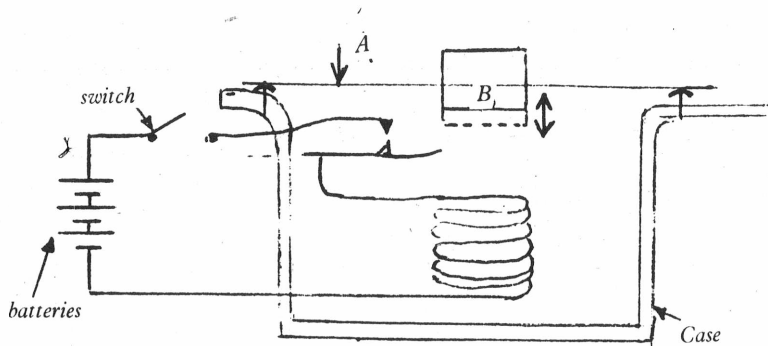

On the diagram "A" is the thin metal circle. When this vibrates it makes the sound of a horn. "B" is the piece of iron which vibrates up and down.

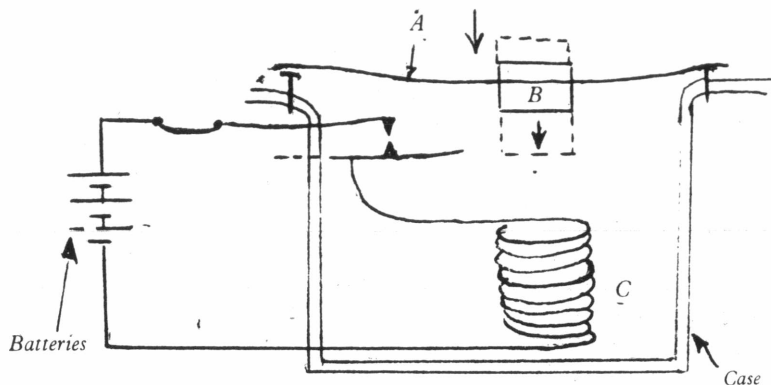

On this diagram "C" is an electromagnet. When electricity flows through "C", the iron "B" is attracted to it. This bends the metal "A" a little. If electricity is stopped flowing through the electromagnet, it will stop attracting the iron. So the iron springs back up as the metal circle "A" is springy.

For the horn to make its sound, the metal circle "A" must keep moving up and down. So the iron "B" must keep being attracted to the electromagnet, then springing away from it.

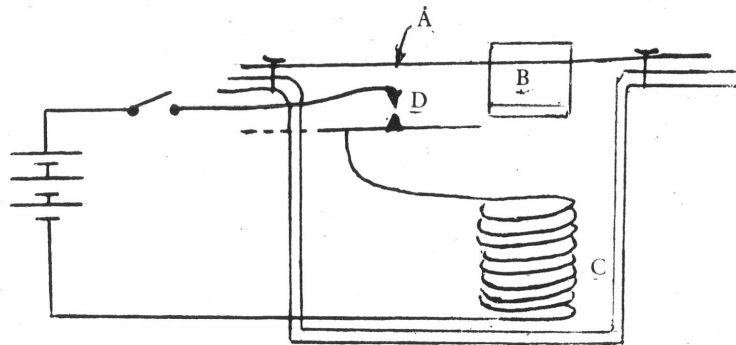

On the diagram the electricity flows through two pieces of metal which just touch at "D". If these two metals move apart, only a little, then the electricity will not flow through.

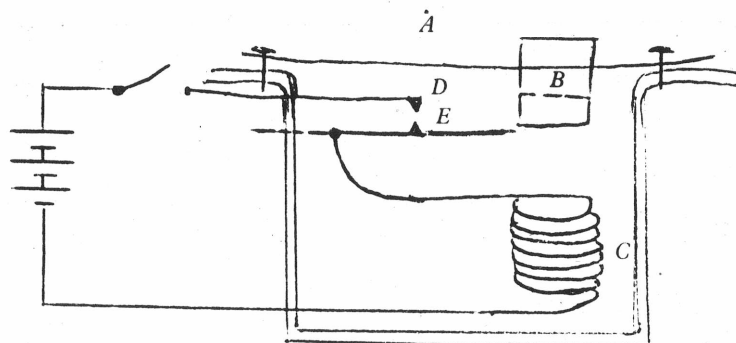

On the diagram, as the iron "B" moves down to the electromagnet, it touches a springy bar of metal "E". This moves a little and makes the two metals move apart at "D". Then the electromagnet no longer attracts the iron. So the iron "B" and the springy metal "E" springs back up. This closes the contact at "D" which allows electricity to flow again. Then the iron "B" is pulled down, it moves the metal "E" and stops the electricity flowing. In this way the metal "A" vibrates up and down. This makes the sound of the car horn.

## QUESTIONS:

1. What is an electromagnet?
2. What moves inside a car horn when you press the button on?
3. Why does it move?

(Answers next week).



# Siune I Indenpenden Long Taim Ileksen



MATTHEW SIUNE

**PRIMIA** bilong Simbu, Mathew Siune, em i wanpela provinsal lida husat i no laikim tru tok kros bilong pati politiks long go insait long provins bilong em.

Em i laik ranim gavman bilong pipel bilong em gut na em i no laikim ol kain toktok bilong politikal pati i paulim tingting bilong em.

Dispela tingting bilong Mista Siune bai go wantaim em bilong bungim tingting bilong

pipel bilong Simbu long ileksen em bai kamap long 2 Jun. Mista Siune em i no sapotim wanpela bikipela pati na em i no laik bai wanpela pati i mas ranim gavman bilong Simbu.

Simbu em i asples bilong lida bilong Nesenel Pati na lida bilong oposisen insait long nesenel palamen, Mista Iambakey Okuk. Tasol narapela pati tu husat inap long traim putim sampela kendidet insait long ileksen bilong Simbu em Pangu pati. Minista bilong Disentralisen, John Nilkare, em i wanpela Pangu man. Na bikos em i winim laik bilong planti pipel bilong Simbu provins, em i soim tu olsem Pangu i stap long blut bilong planti pipel bilong Simbu.

Em i hat long ol bikipela pati i bihainim laik bilong Mista Siune na stap longwe long ileksen bilong Simbu Provins. Sapos Nesenel Pati i no

gat sans long winim Pangu long ol arapela provins, bikipela sans tru bilong em i kamap nau long provins bilong Nesenel Pati stret long Simbu.

Olsem na planti pipel bai putim ai long ileksen bilong Simbu. Pepa bilong statim ileksen bai i go aut long Fonde 26 Epril. Nominesen bai stat long Fraide 27 Epril na pinis long 11.00 klok moning long Fraide 11 Me. Tot bai stat long Sarere 2 Jun na pinis long Sarere 23 Jun. Bai ol i kisim bek pepa bilong ileksen long 3 Julai.

Wok bilong kaundim ol vot bai stat long apinun bilong de em ileksen i pinis long en. De ol i stat long kaunim ol vot bai stat long 6 klok apinun long 23 Jun na bihain long ol i kaunim olgeta vot bai olgeta pipel bilong Simbu inap save long sapos gavman bilong ol bai i namel gavman o sapos wanpela pati bai go pas nau long provins.

## OL TRABEL LONG PNG

Long Iavakaka viles Rabaul, Is Nu Briten Provins. Wanpela man i bin traim long bagarapim wanpela meri i gat 20 krismas. Meri ya tu bilong Iavakaka viles.

Long Morgan kem long Arawa, Not Solomon Provins wanpela meri i gat 35 krismas bilong Mt. Hagen i hangamap na indai.

Meri ya wantaim ol sampela pren meri bilong em i bin dring bia na em i kros wantaim man bilong em na i go stap long haus bilong ol dispela pren bilong em. Meri i wari nogut tru na bihain long emi dringim sampela bia pinis em i go insait long ples bilong waswas taitim laplap long ain long ples bilong waswas na long lek bilong em na em i hangamap. Bihain pren meri bilong em i go na painim na ol i karim bodi bilong em i go ausait. Nau bodi i stap long Arawa haus sik we dokta bai katim na lukim samting i mekim em indai.

Meri ya wantaim sista bilong em i bin lusim viles na wokabaut i go long gaden na man ya i holim pasim meri na pulim em i go long bus klostu. Sista bilong meri i singaut ran i go kisim mama bilong em i kam na tupela i paitim na

hamaim man ya long bikipela hap diwai na man i ranawe na em ino bagarapim meri ya. Dispela birua i kamap

long 20, Epril. Long Wapenamanda, ol sampela lain em Plis i wok long painim yet wanem man i bin katim

nek bilong wanpela meri. Meri ya i bilong Yaipos viles long Wapenamanda. Em wantaim narapela meri i bin wokabaut i go

CALLING ALL  
BANDS  
WE SELL

- amplifiers & speakers
- drumsets, sticks, skins
- guitars; electric; bass and ordinary
- strings & keys
- Music Books
- na ol kainkain

samting long music

BATTERY GUITAR  
AMPLIFIERS

- \* Lead Rythem — K75.00
- \* Bass — K90.00
- \* Special Lead Rythem — K95.00

ROOK'S RADIO

PO BOX 191 LAE  
behind B.P.  
PH-42 4616

## Namba wan samting em i gutpela helt long olgeta famili.



Famili i gat gutpela sindaun bai i hamamas. Johnson & Johnson i gat olgeta samting bilong mekim famili bilong yu helti na lukim gut.



Johnson & Johnson



We all love sugar. With our National sweet tooth consuming close to 30,000 tonnes a year, we were paying a huge sugar import bill, but not any more. The Ramu sugar project at Gusap in the Madang Province is the largest and most successful agricultural project ever undertaken in Papua New Guinea. Now Ramu has 6,000 hectares of sugar cane under cultivation and a factory capable of processing 3,000 tonnes daily into the natural cane sugar that we buy in our local stores today. And Ramu, as well as supplying our nations sugar needs, produces an export surplus that is very much in demand overseas for its "natural cane" qualities

# PNG SWEET ENERGY



# Lusim tingting long Wes Sepik

Dia Edita - Long lukluk bilong mipela ol pipel bilong Wes Sepik i luk olsem Praim Minista Michael Somare i no helpim tumas Vanimo taun na ol distrik bilong en long Wes Sepik.

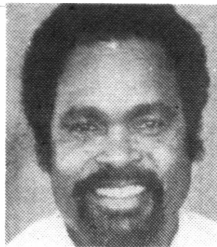

• SOMARE

Dispela i soim olsem em i no gat laik o interes long Wes Sepik, tasol bikpela interes na laik bilong em i stap tasol long Is Sepik. Na nau yu ken lukim Wewak taun na ol distrik bilong en i moa yet long olgeta wok developmen na olgeta samting.

Tasol ol Wes Sepik pipel i wari long wanem ol i givim nating 5-pela memba i go long Pangu na givim vot nating long Somare kamap Praim Minista. Mipela ol pipel bilong Wes Sepik i glasim olsem em i taim long mekim Wewak i kamap namba 3 o 4 siti long

Tok Save i go long ol man i save salim pas long Wantok. Sapos yu no putim nem tru bilong yu long pas mipela i no inap prinim leta bilong yu.

PNG.

Sapos Somare yu laik helpim Wes Sepik orait pasim tok long Vanimo Timba hariap tasol. Nau mi bilip olsem Pangu i no karim gutpela kaikai.

Andrew Malken, Maui Sevis stesin, Lumi, WSP.

# Patrol Gut Long Nait

Dia Edita - Mi wanpela meri Wes Nu Briten na mi laik toktok long ol plisman long Kimbe. Planti taim mi save lukim olsem ol man i brukim supamaketa na BMS opis na stil. Na yupela ol plisman i save putim ai bilong yupela i go we?

Ating yupela i laik pinisim mani bilong gavman tasol ya? Long san yupela i save pulim soks na taitim su i go i kam, na bai ol manmeri i lukim yupela na pretim yupela. Tasol long nait yupela i no save wokim gut wok bilong yupela.

Ating yupela i save go slip o go we? Yupela i save stori tasol long opis bilong yupela na i no save raun liklik long ol hap

kona bilong ol stua o opis nabaut. Yupela i save kaikai buai na smok tasol na long tulait nau bai bos man bilong yu i ting olsem yupela i wok gut tru long nait, tasol nogat tru.

Long taim trabel i kamap bai lek i tait long go i kam long painim ol stilman. Ausa bilong husat? Em rong bilong yupela ol dispela plisman. Traim tingting gut na raun long nait. Was long ol stilman. I no ol man bilong asples husat i save brukim ol stua na BMS opis, nogat. Em ol man long blok husat i no gat wok na i raun nating.

Plis sapos yu no gat wok mobeta yu go bek long provins bilong yu na

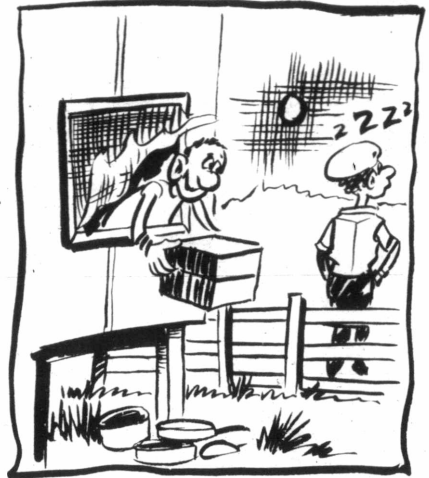

yu ken stil long hap bilong yu yet. No ken kam na bagarapim nem bilong Wes Nu Briten. Mi yet mi lukim long ai

bilong mi long taim ol i kot.

Therry Ragi, Kimbe, WNB.

# Kaikai long ples bilong wok

Dia Edita - Mi laik askim yu long wanpela samting em mi save lukim planti taim long Hagen taun na i no stret long ai bilong mi.

Planti taim tru mi save lukim ol man i wok insait long ol food bar o haus kaikai i save mekim dispela pasin. I no ol wokman bilong wanpela haus kaikai tasol i save mekim dispela pasin em ol wokman long ol arapela haus kaikai tu i save mekim kain pasin olsem.

Long taim bilong wok em i taim bilong wok tasol. Em i no taim bilong kaikai. Planti taim mi save lukim ol wokman stret bilong kaikai baus i save mekim dispela pasin na i no ol narapela man. Ol i save kaikai wantaim na wok.

Long taim wanpela i sevim mipela ol kastama planti ol i sanap wantaim ol hap fis na sip long ol kona bilong haus kaikai na kaikaim i stap. Ol i save mekim dispela pasin na planti taim mipela i save tuhat nating.

Na tu planti taim ol wokman i save go let long

wok na ol skol boi tu i save go let long skol long wanem ol i mas wet long baim kaikai bilong ol.

Long dispela pasin tasol mi laik tokim yupela ol brata olsem yupela i no go long wok, nogat tru ya. Yupela i go long kaikai tasol.

Sapos yupela mekim olsem na bos i katim pe bilong yupela em bai no gat tok long en bikos yupela i no wok. Yupela go long kaikai tasol.

Narapela samting tu mi laik askim yupela ol wokman, yupela i save kaikai long moning tu o nogat? Ating yupela i no wok mani bai yupela inap long baim kaikai na kukim brekfes bilong yupela long moning.

Narapela smating moa mi save lukim em taim yupela i save sevim ol kastama ol i save kisim ol flaua bol o pis samting long han tasol. Ating no gat helt inspekta long Hagen taun. Long ol hap olsem Wewak, Madang na Laek i no gat pasin olsem i save kamap. Haus kaikai i gat sisib bilong em yet bai ol inap kisim kaikai na putim i go insait

long pepa.

Em tasol. Sapos yu husat i gat komplek o wari long dispela orait rait tasol i go long Wantok Niuspepa na bai mi lukim.

Jack Pini Maun Hagen.



# Gan i no pawa

Dia Edita - Mi laik bekim pas bilong brata ya em Eddie Hafun bilong Madang Provins. Na em bin rait long Wantok namba 511.

Eddie yu bin tok ol plis i ken kilim man long gan. PNG em Kristen kantri. Na mi laik tokim yu stret olsem i no gat wanpela baibel buk i tok olsem. Sapos wanpela kristen man i wokim trabel ol plis i mas sutim em long gan.

Ating yu rong tru long mekim kain toktok. Long kantri bilong yumi PNG i no gat wanpela lo i tok sapos man i wokim rong na ranawe ol plis i mas sutim em long gan.

Sapos man i wokim rong na brukim lo bilong PNG, orait em i mas kisim bikpela mekim save

na kisim taim long kalabus.

Brata yu no ken subim ol plisman long kilim man long gan. Sapos wanpela brata bilong yu i stil na ol plis i bungim em na kilim em long gan bai yu mekim wanem? Yu tu belhat na i laik kirap na pait wantaim ol plis. Em olsem yu brukim lo na pait wantaim. Olsem na plis kirap kilim yu long gan. Olsem na yutupela wantaim indai na nogat kot bilong yutupela.

Brata Eddie yu mas redim dispela pas na i no ken sapotim plis long yusim gan. Narapela taim yu mas wasim pes gut na rait long Wantok Niuspepa.

Robert Onzo, Arawa, NSP.

# Samonim nating man

Dia Edita - Mi bin lukim wok komyuniti gavman long Buin i no mekim wok olsem mi ting ol mas bihainim. Sampela samting ol i bin mekim long mi, em mi painim i no stret tru.

Pastaim tru, mi bin wok inap 6-pela mun nau na mi no bin lukim wanpela polisi pepa em ol wokman bilong komyuniti gavman i mas bihainim. Mi ting dispela em bikpela samting tru. Ol wokman bilong wanem kain kampani o gavman bodi i mas save bipo long ol i wok, wanem kain samting dispela wok bilong ol i tingting long kamapim long kantri.

No gat tu tok klia olsem dispela komyuniti gavman i regista nem bilong yu pinis long rol kol buk bilong ol o no gat. Ol i no makim tu sapos yu marit, na wanem ples yu kam long en.

Ol i no tok save tu sapos yu mas baim het takis. Na

sapos yu mas kamap long wok bilong komyuniti gavman na sapos yu no bihainim ol dispela polisi o lo, em bai yu go kot na inap kalabus.

Mi n bin kisim ol dispela tok save. Olsem na mi kirap nogut long painim wanpela samon pepa i kam long mi long mi mas baim hariap K38 kina olsem het takis.

Mi laik tok strong long ol komyuniti gavman olsem, sapos yu laik lukim ol man bilong narapela provins i stap long provins bilong yu i bihainim lo bilong yu, pastaim tru, yupela yet i mas tok klia long ol long olgeta wok bilong yupela. Mobeta yu bungim ol dispela kain manmeri na tok save long ol long wok bilong opis bilong yu.

Em i no gutpela pasin long mekim ol wokman i kirap nogut long painim samon pepa bilong baim

het takis hariap. Na bai mipela i mekim wanem taim mipela i lukim olsem dispela samon i tok, "Sapos yu sakim tok long samon pepa, bai yu go kalabus 6-mun."

Mi laik pinisim tok bilong mi olsem. Sapos ol komyuniti gavman i laik sevim gut ol pipel bilong komyuniti bilong ol, plis ol lida, yupela i no ken go fowat tumas long givim aut samon pepa na kotim nating ol manmeri husat i no klia long wok komyuniti gavman.

Traim na lukluk bihain tu, na helpim ol pipel. Sapos yu helpim ol pipel, bai yu no ken ketpen bihain long ol. Mi tok stret long yupela, wok bilong yupela tru em long helpim ol pipel long bihainim trupela rot. I no ken kotim ol nating.

Joel Y.T, Buin, NSP.

# BINGO

5-55-91 4-66-99	74-22-49 25-87	37-80-19 14-97-50	62-44-9 71-11-20	30-79-26 69-41-83
--------------------	-------------------	----------------------	---------------------	----------------------

NO:6

Pilai i go olsem makim wanpela namel long ol 6-pela namba aninit long I na NnaG na O Mipela helpim yu na makim pinis namba 29 aninit long B. Tingting gut - makim na salim i kam long: Wantok Bingo - Box 1982, Boroko. Hariap salim kwik. Resis ya bai go inap long 4-pela wik. Sapos i nogat wina man i klostu long win bai kisim K10.

Nem: \_\_\_\_\_  
P.O. Box: \_\_\_\_\_  
Taun: \_\_\_\_\_

**Dokta I Wet Tasol**



Dia Edita - Mi bekim pas bilong Moses Toang bilong Toalip viles, Not Solomons Provins.

Brata Moses, bilong Toalip viles, mi laik save dispela ol nem em i nem bilong viles bilong yu o yu bin mekim dispela nem tasol.

Mi laik tokim yu olsem long taim mi kam hia long Panguna Helt Senta long 24-2-80 i kam inap nau, mi no save harim dispela kain nem bilong viles bilong Toalip o Moses Toang.

Mi laik save yu kam we o long wanem hap insait long dispela provins Toalip viles istap long en. Sapos yu kam long wanpela Komyuniti Gavman insait long Panguna eria o ausait mi mas tokim yu olsem yu westim taim bilong yu laka?

Yu bin tok mi save rausim ol sikman na meri na pikinini na tokim ol long sindaun na go long arapela hap na westim taim.

Moses Toang mi askim yu sapos yu man bilong dispela eria, yu bin stap

we o sindaun long wanem kona long Panguna haus sik na mi bin tok ol dispela samting.

Mi laik yu tokaut long de, wik, mun na taim yu yet i harim long yau bilong yu, ol dispela toktok i bin kamap long maus bilong mi. Nogut yu harim sampela kain giaman stori o toktok na yu mekim toktok bilong yu yet. Mi no nupela man i wok long gavman nau tasol bai bai mi seksek long ol dispela toktok bilong yu.

Mi save kain pasin olsem sapos yu harim wanpela toktok long arapela manmeri bai yupela i tanim nabaut na toktok hia bai go kamap kranksi olgeta.

Tu yu putim long leta bilong yu olsem em kelaman bilong Buka. Mi laik tokim yu olsem sapos yu laik raitim pas long Wantok Niuspepa yu no ken diskribim man olsem taim yu gat komplem long en. Bikman antap yet i givim dispela kela o wanem samting i stap long skin bilong wan manmeri olsem presen bilong em.

Yes brata bai yu no inap i gat dispela kela, tasol mi tokim yu, mobeta yu pinis long raitim kain pas i go long Wantok Niuspepa, yu mas kam stret na toktok long maus bilong yu yet.

Yu bin tok tu olsem

sapos mi les long wok orait mi mas lusim wok na go bek long asples bilong mi na planim kakao na kokonas long ples. Mi tokim yu olsem, mi ken go long asples bilong mi sapos mi laik. I no gat samting i pasim mi.

Mi tokim yu olsem sapos yu makim maus bilong ol pipel bilong yu, yu ken kam long Panguna haus sik na yumi sindaun gut na toktok long dispela belhevi yu gat wantaim ol pipel bilong yu.

Mi mas tokim yu stret olsem Panguna Helt Senta emi no lukautim olgeta hap long Kieta na Arawa. Panguna Helt Senta i lukautim ol manmeri na pikinini i stap long taun bilong Panguna yet, wantaim ol viles i stap klostu long maining eria.

Long pas bilong yu tu, yu in tok tu olsem gavman bilong tude bai no ken amamas long westim mani long baim ol dispela kain les man olsem mi. Mi askim yu olsem yu save lukim long ai bilong yu olsem mi les man o yu toktok nating tasol.

Sapos yu Moses Toang tru orait mi laik bai yu kam na toktok long mi long maus bilong yu yet. Bai mi wetim yu tasol long lukim yu olsem yu yet i bin tok long pas bilong yu.

Dokta Boi, Panguna Haus Sik.

**Nius Long Motu**

Dia Edita - Olgeta taim Redio Not Solomons i save putim kamap nius long Tok Pisin na Motu i kamap long Redio Wan long Mosbi. Na sapos nius long Tok Pisin i pinis, bai ol pipel bilong Not Solomons Provins i harim yet nius long Motu. Dispela tasol i mekim mipela ol pipel bilong Buka i les pinis.

Dispela provins i no provins bilong Motu na mipela i harim yet tok Motu long redio? Bilong wanem na yupela ol wokman long Redio Not Solomons i save putim kamap nius long motu long lokal stesin bilong yumi?

Long tingting bilong mi, mi save olsem olgeta pipel bilong Not Solomons Provins ol i no laikim dispela Tok Ples Motu. Na watpo yupela ol wokman bilong Redio Not Solomons i save putim kamap tok Motu long redio?

Em tasol liklik wari bilong mi bilong Redio Not Solomon na tok Motu. Mi laikim ol wokman bilong redio Not Solomons i mas lukim na bekim dispela pas bilong mi.

Charles Mikau, Buka Ailan, NSP.

**Kaunsila Pangali I Stap We?**

Dia Edita - Mi wanpela draiva bilong plis ka i stap insait long Isak Vali. Mi laik autim wari bilong mi i go long Wantok Niuspepa na tok save long ol pipel long komplem bilong ol. Mi laik save long wanpela lida, nem bilong em Kaunsila Pangali. Em i stap we tru nau? Long Wabag, Maun Hagen, o long Simbu?

Mi no save lukim dispela man hia long Isak Vali. Ating em dispela man tasol i bin komplem

long plis ka bilong Isak Vali i no save go patrol o wok i go long rot bilong ples bilong em.

Sapos yu lida tru long ples, yu mas wokim gutpela rot bilong ka i patrol i go long eria bilong yu. Stretim tu ol bris na ples daun na malomalo. Sapos ol dispela rot na bris i pinis gut, em bai plis ka i ken raun long eria bilong yupela tu.

Olsem na mi laik tokim kaunsila Pangali, maski long komplem tumas long

ol plis ka bilong Isak Vali, sapos yupela yet i no laik mekim wok helpim ol plisman. Dispela em strongpela toktok bilong mi draiva bilong plis ka long Isak Veli.

Sapos yu husat man o meri i lukim dispela pas, tingting gut long dispela ol toktok bilong mi na putim long het bilong yupela.

Nick S. Avene, Yagos, Wapenamanda.

**ILEKTORAL KOMISIN BILONG PAPUA NIUGINI PABLIK NOTIS SIMBU NA WES NU BRITEN PROVINSAL GAVMAN ILEKSEN**

Olgeta manmeri na ol pipel insait long Simbu na Wes Nu Briten Provins stret i mas kisim toksave gut olsem mipela i givim aut **Vot Pepa (Rit) bilong mekim kamap Namba Tu Jeneral Ilekse bilong Provinsal Gavman long Fonde, Epril 26, 1984. Na dispela **Vot Pepa i stap nau long han bilong ol Ritening Opisa husat i lukautim wan wan Konstituensi insait long dispela tupela provins.****

Ol de na taim mipela i makim insait long **Vot Pepa bilong mekim kamap dispela tupela Provinsal Gavman Ilekse i go olsem:-**

- |  |                              |
|--|------------------------------|
| <b>1 TAIM BILONG NOMINESEN I STAT</b>            | <b>Fonde, 26 Epril, 1984</b> |
| <b>2 TAIM BILONG NOMINESEN I PINIS (11.00am)</b> | <b>Fonde, 11 Me, 1984</b>    |
| <b>3 TAIM BILONG VOT I STAT</b>                  | <b>SARERE, 2 Jun, 1984</b>   |
| <b>4 TAIM BILONG VOT I PINIS</b>                 | <b>SARERE, 23 Jun, 1984</b>  |
| <b>5 TAIM BILONG KISIM BEK VOT PEPA</b>          | <b>Tunde, 3 Julai, 1984</b>  |

Dispela tok save i kam long:-

**ANDREW S. TRAWEN EKTING ILEKTORAL KOMISINA**

**PLANTI HALIVIM LONG HONDA**

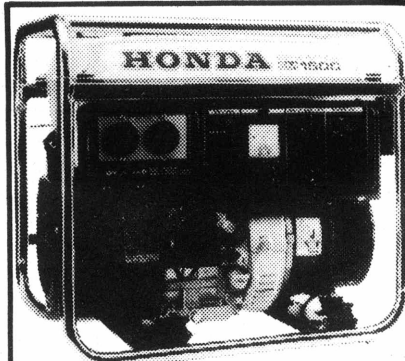

**GENERETA SET**

LONG KISIM PAWA OLGETA TAIM ..... MAKIM HONDA

- LIKLIK NOISE
- I STRONGPELA
- ISI LONG KARIM RAUN
- I KOS LIKLIK LONG RONIM

**MEKIM WOK BILONG BURUKIM GIRAUN I ISI YUSIM HONDA TILA**

- NOGAT BIRUA
- ISI LONG YUSIM
- EM INO HEVI TASOL I STRONGPELA

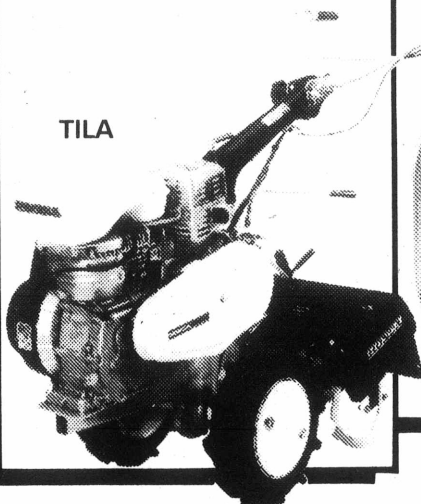

**TILA**

**LONG PAMIM GUT NA STRET - YUSIM HONDA WARA PAM**

- LIKLIK TASOL MOA PAWA
- ISI LONG OPERETIM
- LIKLIK MENTENENS

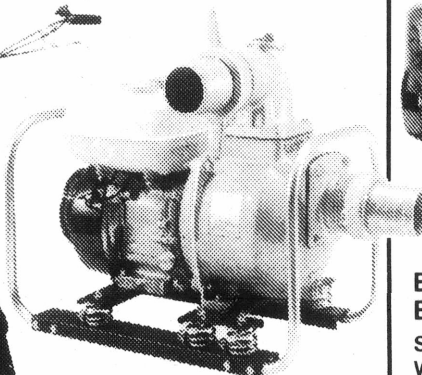

**WARA PAM**

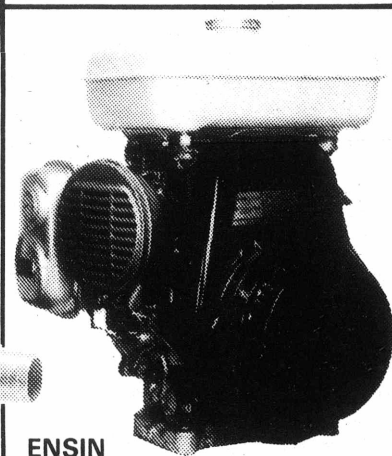

**ENSIN BILONG KAINKAIN WOK SENISIM OLPELA ENSIN WANTAIM WANPELA HONDA**

- OL I WOKIM GUT NA STRONG
- INO HEVI
- MOA PAWA ..... NOGAT NOIS

**KWALITI BILONG HONDA BAI ISTAP LONG TAIM**

Long moa toksave long **HONDA PAWA PRODAKS** — sekim Steamships Machinery istap kolostu long yu o ol Honda dila nambaut.

HONDA — EM OL I SALIM NA SEVISIM LONG

HEB 2102



NA TU LONG OL HONDA DILA NAMBAUT LONG PNG.



## Boipren I Paul

DIA LAIPLAIN,

# LAIP

Long taim mi bin stat wok mi bin bungim wanpela yangpela man. Nau mitupela i stap wantaim inap 4-pela yia olgeta. Long taim mitupela i bin lip, mitupela i bin go wantaim long ples bilong mi, na papamama bilong mi i laikim em tru.

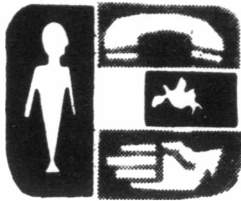

# LAIN

Bihain long mitupela i kam bek long wok, ol bos bilong mi i bin salim mi go wok long narapela provins. Dispela boipren bilong mi i save raitim pas i kam long mi na em i tok bai mitupela i marit bihain long sampela yia.

Mi gat strongpela laik long em olsem na mi no save raun wantaim ol arapela man. Tasol nau sampela pren bilong mi i tokim mi olsem dispela boipren bilong mi i save raun wantaim ol arapela meri.

Yu ting wanem? Bai mi maritim dispela man o em i kain man bilong paul nabaut? Inap yu helpim mi plis.

WARI.

DIA PREN

Em i tru olsem long taim yumi harim sampela lain i tokim yumi kain stori olsem long ol man o meri yumi laikim, bai yumi wari tru. Na sampela taim ol dispela stori i no tru, tasol tingting bilong yumi bai wari na paul long taim yumi harim ol kain stori olsem.

Yu tok olsem yu harim ol dispela stori, tasol yu no tokim mipela sapos yu askim dispela boipren bilong yu tu long ol dispela stori o nogat.

Dispela stori inap long bagarapim laik bilong yutupela olsem na mobeta yu yet i toktok wantaim em long dispela ol stori yu bin harim long ol pren bilong yu. Na i gutpela sapos yutupela i sindaun wantaim na toktok long dispela samting. Sapos yu no inap tru long lukim em, orait, ringim em long

telepon o salim pas i go long em na askim em long ol dispela samting.

Na long taim yu toktok long em, i gutpela sapos yu toktok stret na maski long belhat wantaim na toktok. No ken belhat wantaim na sutim tok nating long em. Sapos yu mekim olsem, bai em i ken kros na lusim yu. Planti taim ol dispela kain stori em ol tok win tasol na i no gat as long ol.

Sapos ol dispela stori i tru, orait yu yet i mas skelim tingting nau na tokaut stret long man ya long ol tingting bilong yu.

Na bihain long yu yet i toktok wantaim em na harim kain hap tok em i givim yu, orait, yu ken skelim na lukim sapos em i kain man yu laik maritim o nogat.

Nogut em i laik toktok tasol long ol arapela meri na sampela lain i lukim na ol i ting em i raun wantaim ol dispela meri. Planti taim ol man i save gat tupela tingting long husat meri tru ol i laik maritim. Yu no ken wari tumas, ating em i laikim yu tru tasol ol arapela meri ya em ol pren nating tasol.

Sapos yu no inap long luksave long ol dispela samting ating bai yu pasim tingting long lusim em.

Tasol bipo long yu skelim tingting i gutpela sapos yu panim aut as bilong tok na skelim gut tingting.

MI LAIPLAIN.

Sapos yu gat wari o askim salim i kam long Laipplain Box 6047, Boroko.

## Tuhat Long Mosbi



• Draipela san long Mosbi i save mekim nek bilong man i drai. Olsem na Tioti na Andrew i mekim save i stap long tep wara.

# Haiskul Na Kaunsil Kros Long Kakaruk

**TUSBAB** Haiskul na Madang Taun Kaunsil i skruim yet pait bilong ol long kirapim wanpela kakaruk fam.

Tusbab. Haiskul i laik ranim yet wok bilong ol long lukautim kakaruk long skul fam. Tasol sampela kaunsila long Madang taun i toktok strong yet long rausim dispela fam, na pinisim olgeta.

Kaunsila Anthony Tsora i tok olsem, em i harim sampela toktok i kamap olsem Tusbab Haiskul (bilong gavman) i laik kirapim gen projek bilong lukautim kakaruk long skul graun. Na em i no laik bai Tusbab Haiskul i gat kakaruk projek long dispela yia yet.

Tasol sampela kaunsila i tingting narakain. Kaunsila Timo Paino i tokim kibung bilong ol kaunsila long Tunde, Mas 27 olsem, ol kaunsila

mas tingting tu long ol pikinini na papamama bilong ol pikinini husat i skul long Tusbab Haiskul.

Em i tok, "Taim kakaruk fam i bin stap yet long Tusbab, ol pikinini i save baim liklik mani tasol long skul fi bilong ol. Kakaruk fam i save kamapim mani long helpim ol."

Hetmasta bilong Tusbab Haiskul, Luke Arel i sapotim toktok bilong Kaunsila Paino long ranim gen kakaruk fam long skul bilong em.

Em i tok, "I tru olsem long 1978 i kam inap long 1981, taim kakaruk fam i stap yet, mipela save mekim mani long baim skul fi bilong ol studen. Na saplaim kiau na kakaruk olsem kaikai bilong ol pikinini long skul. Olsem na mi laik kirapim gen dispela kakaruk fam."

Mista Arel i tok olsem, long 1978 inap 1981, ol studen i save baim K145 (boda studen) na K55 (de studen) bikos kakaruk

fam i stap long helpim ol baim hap mani. Nau, ol studen i baim ful pe, K180 (boda studen) na K90 (de studen).

Planti toktok i kamap long dispela kibung ol kaunsila na Madang Taun Sinia Helt Inspekta, Leo Nepes i tok olsem em i no save long wanem nupela ples Tusbab Haiskul i laik kirapim gen kakaruk fam bilong ol. Olsem na em i no inap givim tok orait bilong em long ol.

Hetmasta bilong Tusbab i tok gen olsem, "Mipela i no bin toktok long senisim ples bilong fam. Dispela fam bai stap yet long wankain ples em bin stap bipo. Tasol nau bai mipela i kamapim nupela developmen long fam.

"Bai mipela i rausim kunai haus na sanapim simen na kapa haus, bai isi long rausim pekpek bilong kakaruk long wan wan de. Olsem bai no gat smel nogut i kamap na no gat planti lang bai pulap long strit klostu."

Wanpela kaunsila husat i stap long kibung bilong Madang Taun Kaunsil long Mas 27, Kaunsila John Aupae, i askim kibung sapos Tusbab Haiskul i bin kisim tok orait long Madang Lokal Medikel Atoriti (Taun Kaunsil yet) long kirapim namba wan kakaruk fam bilong ol.

Kuskus bilong Madang Taun i tokim ol kaunsila olsem, Tusbab Haiskul i no bin kisim tok orait long kirapim namba wan kakaruk fam bilong ol tu long 1978.

Nau olsem wanem? Long 1978 yet Madang Taun Kaunsil i no tingting long sekap long dispela fam long Tusbab Haiskul? Husat tru bai win nau. Sampela kaunsila i helpim Tusbab Haiskul na sampela i gat belpen long dispela kakaruk projek. Tusbab Haiskul i redi pinis nau long go het wantaim dispela projek bilong ol.

## Plis Ripot

**LONG** Sabama setelmen long Mosbi ol stilman i bin stil long J.A. Wong tret stua. Ol i bin draivim ka i go kamap long dispela tret stua na wanpela man i go insait kisim olgeta mani i stap long kes rejista na ol i ranawe long ka. Ol dispela man ya i bin stilim tu dispela ka ol i ranawe long en. Dispela birua i bin kamap long 14, Epril.

Long 13, Epril long Gordon, Mosbi ol stilman i bin brukim flai waia bilong wanpela haus na go insait na stilim ol samting i kos moa long K3,000. Plis i no bin inap long painim hariap dispela ol stilman.

Long 14, Epril ol trabel man i bin brukim opis bilong Hagen Intanesenel Parimeri skul long Westen Hailans provins na stilim ol klos bilong ol pikinini na planti kain kain samting em ol tisa i save yusim long givim skul long ol pikinini.

Plis i sasim pinis wanpela man husat i bin brukim haus i go insait long Apoito viles long Goroka na stilim K887.

Long Kambiamul viles klostu long Hagen wanpela man i bin holim pasim wanpela meri i gat 25 krismas na bagarapim em. Dispela trabel i kamap long 15/4/84. Man ya i bin tokim meri ya olsem bai em i go long Hagen Pak Motel na dispela meri tu i go wantaim em. Tasol popaia man ya i kisim meri i go olgeta long Kambiamul na bagarapim em.

Long Hohola, Mosbi wanpela man i bin go insait long haus bilong narapela man na paitim papa bilong haus. Trabelman i bin paitim em long tupela emti botol. Na papa bilong haus ya i bin kisim bikpela bagarap long pes na het bilong en. Dispela asua i bin kamap long 12, Epril.

Long Mt. Hagen tupela man i bin sindaun dring wantaim long 5, Epril na wanpela bilong ol i kirapim i laik kilim narapela. Trabelman i stat taim tupela wantaim i spak nogut tru na i laik go long haus long wanpela ka.

Draiva i tokim pren bilong em long lusim ka i go aut. Taim poroman i no harim tok draiva i sutim em long naip planti taim na klostu em i kilim indai man ya.

Long Manus wanpela man i bin bagarapim wanpela yangpela meri husat i gat 14 krismas. Meri ya wokabaut i go long haus bilong liklik mama bilong em long Nadranou viles. Na man ya i bin ran i go bihain na holim pasim em.

WORD

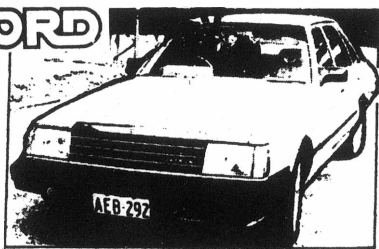

**SURPLUS OVER REQUIREMENTS**

**12 MONTH OLD NISSAN DATSUN LAUREL IN FABULOUS CONDITION—AUTOMATIC, TINTED WINDOWS, ONLY 18,000 KMS ON THE CLOCK. COSTS K13,600 NEW — FIRST OFFER OVER K6,499 ACCEPTED.**

- \* STEREO RADIO AND CASSETTE.
- \* AUTOMATIC BURGLAR ALARM.
- \* FULL AIR-CONDITIONING.
- \* ELECTRIC WINDOWS.

inspection can be arranged by ringing

**DISTRIBUTION  
MANAGER 25 6151**



# Lusim Wabag I Go Kamap Long Hagen

Pater Philip Gibb bilong Holi Spirit Senta, Par, Enga Provins i salim stori na poto.

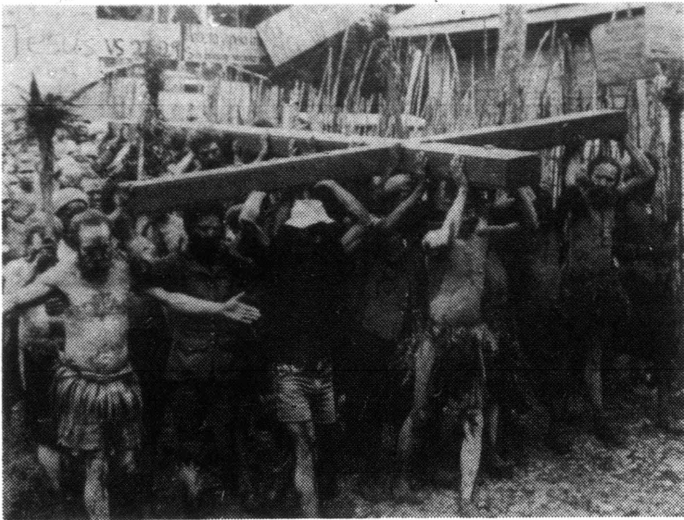

Ol pipel bilong Wagab Daiosis i karim dispela bikpela kros raun long ol peris.



**OL pipel bilong Wabag daiosis long Enga Provins i wok long karim wanpela kros na bai ol i wokabaut i go kamap long Hagen wangepela de bipo long Pop Jon Pol 2 i kamap long Hagen.**

Ol i bin stat long

karim dispela kros long Kandep long Epril 1, na ol i raun pinis long 8-pela peris. Ol sampela peris olsem Porgera na Keman em i insait tru long bus i bin salim sampela pipel i go bungim dispela kros long taim ol i bin harim olsem kros ya i kam klostu long ples bilong ol.

Planti pipel i wok long bihainim rot

bilong dispela kros. Long taim ol i bin karim dispela kros i go kamap long hap bilong Sari long Wabag, em long Gut Fraide stret. Olsem na ol pipel husat i karim dispela kros i bin putim ol bilas bilong sori. Na moa long 2,000 pipel i bin wokabaut bihain long kros long dispela de.

Na long Ista Mande

ol pipel i bin karim dispela kros long Wabag i go long Par. Ol pipel i bin amamas wantaim na karim kros ya long wanem em i Ista pinis na ol i tingim Jisas i kirap long indai bilong em. Olsem na ol pipel i singsing wantaim na bilas long soim amamas bilong ol long taim ol i karim kros i go.



## Sande lotu

Frank Mihalic

2 SANDE BILONG ISTA

29 Epril 1984

Wanpela lain yangpela bratasusa na kandere i sindaun na tok fani na tok pilai long haus bilong lapun mama. Ol i liv long skul nau. Mama ya i smokim paip bilong em na i sindaun harim ol stori bilong ol na i lap wantaim. Ol yangpela i laikim lapun mama, na sampela taim tu ol i laik traim em long kain kain askim .... na oltaim ol i kalap nogut long ansa bilong em.

Orait, long dispela de kandere Tom i askim lapun olsem: "Mama, yu save go long lotu olgeta Sande olsem bipo, o nogat?" "Yesa," mama i bekim tok. "Mi no ken lusim wanpela Sande."

Tom i askim nau, "Inap yu ken tokim mipela, Pasto i bin toktok long wanem samting tude?"

"O sore," mama i tok, mi save moa. Het bilong mi i ston pinis."

"Orait, yu tokim mipela, em i bin ritim wanem stori long baibel?" Mama i bekim tok, "Mi save tasol, pasto i bin mekim gutpela toktok tru. Em i tok wanem, mi no moa save."

Nau Tom i pulim pilai na i tok, "Oloboi, mama, bilong wanem yu go long lotu? Yu no kisim wanpela samting. Yu no inap bringim wanpela gutpela tok i kam bek long haus. Yu westim taim tasol."

Na lapun mama i sarap i stap. Na ol yangpela i sem long Tom i bin putim hevi long mama .... Bihain liklik, lapun mama i sanap na i tokim ol, "Yupela ol manki i kam wantaim mi."

Orait, nau ol i go long haus kuk na mama i kisim bilum bilong em na i tokim Tom, "Hia, Tom, Yu kisim dispela bilum na yu go long baret na pulmapim long wara na karim i kam bek." "Mama, yu tok pilai. Yu save pinis, i no gat man inap long karim wara long bilum," Tom i tok. Tasol mama i strong na i tok: "Maski. Yu go mekim tasol olsem mi tok .... mi laik skulim yupela liklik."

Orait, nau Tom i go long baret na i kam bek na i holim bilum i lait olgeta na i gat wara nabaut long ol string bilong en. "Yu lukim, mama," em i tok, "I no gat wara insait long bilum."

"Yes. Mi save pinis," mama i tok.

"Dispela bilum i olsem het bilong mi, em i no inap holim wanpela samting." Nau em i smail na i tokim ol, "Tasol yupela i lukim, nau dispela bilum i klin gen."

Nau wanpela yangpela i lukim narapela na i smail. E - dispela lapun mama i gat klewa tingting .... Nau ol i amamas na i paitim han na i tenkyu long lapun long skul stori bilong em.

Ating yu yu kisim dispela skul? I olsem: Oltaim lotu i save helpim laip bilong yu liklik, na long sampela we, yu no save kam bek emti long lotu.

Yumi gat tok long lotu, long wanem, tude long Gutnius yumi tok tupela taim long stori bilong ol aposel i bung. Bihain long Ista ol i pret yet, olsem na ol i bung i stap. Em i pasin bilong olgeta wankain enimal na wankain pasin ol i save bung long taim bilong pret. Olsem na ol i strongim bel bilong ol. Yumi manmeri i wankain ....

Na yumi lukim Tomas i kisim tabel, long wanem, em i stap ausait longwe long dispela bung dispela grup. Sapos yumi stap longtaim longwe long liklik grup o famili bilong ol Kristen, yumi no inap sanap strong long bilip na pasin Kristen. Sampela Kristen i kolim grup olsem "felosip."

Long rit i kam long Wok bilong ol aposel 2,42-27, ol i stori long ol pasin bilong namba wan Kristen Komyuniti. Ol i kisim skul wantaim, ol i amamas long onaim God wantaim, ol i bungim olgeta mani na kaikai samting wantaim, ol i go long lotu olgeta de. Tude ye de lukim dispela samting long pasin bilong sampela lain pris o Brata o Sista. Ol i mekim wankain olsem ol namba wan Kristen komyuniti tru em i famili.

Long hamas Kristen famili bilong tude papamama na ol pikinini i save nildaun beten olgeta moningtaim o nait? Wataim ol i save ritim Baibel bilong ol? Sapos yumi no mekim nau, bai olgeta pikinini i kamap olsem haiden. Pikinini bilong yu save beten "Papa Bilong Mipela" o nogat? Tude planti Kristen haikul studen i no save. Yu traim ol tude, na bai yu kalap nogut .... na bai yu tingting planti.



### Laip bilong Jisas

JISAS I WASIM PINIS LEK BILONG OL DISAPEL, NA EM I SINDAUN GEN LONG TEBOL.

I TRU, MI BIKPELA NA MI TISA BILONG YUPELA, TASOL MI WASIM LEK BILONG YUPELA. ORAIT YUPELA TU I MAS WASIM LEK BILONG OL BRATA BILONG YUPELA. WOKBOTI EM I NO ANTAP LONG BIKPELA MAN BILONG EN.

BIHAIN LIKLIK JISAS I MEKIM WANPELA TOK NA OL I KIRAP NOGUT.

WANPELA NAMEL LONG YUPELA BAI I GIVIM MI LONG OL MAN I BIRUA LONG MI.

BIKPELA, YU TOK LONG HUSAT?

JISAS I MAKIM HUSAT MAN TAIM EM I GIVIM HAP KAIKAI LONG EM? EM JUDAS TASOL.

ATING MI, A?

EM TASOL. ORAIT SAMTING YU LAIK MEKIM, EM YU MEKIM KWIK.

TAIM JUDAS I KISIM DISPELA KAIKAI, SETEN I GO INSAIT LONG EM. KWIKTAIM EM I GO AUSAIT, TASOL OL DISAPEL I NO SAVE LONG AS BILONG DISPELA.

Kristen Buk Melanesia (Box 488, Wewek) i tanim dispela komik i kamap olsem buk bilong ol. Sapos yu laik yu ken baim long ol. Copyright 1973. David C. Cook Publishing Co. All rights reserved.





# Popaia long was long mun

**BIPO bipo tru long taim bilong ol tumbuna i gat wanpela man na meri bilong em na tupela pikinini meri bilong ol i save stap long ples bilong ol.**

Wanpela nait man ya i kirap na tokim meri bilong em.

"Yu na ol pikinini i stap. Bai mi go was long mun."

Man ya i tok olsem na em i kirap kisim bilum, paia, spia, banara na naip bilong ol tumbuna na em i wokabaut i go i go inap em i kamap long ples we em i ting bai em inap long was long mun.

Em i kamap long dispela hap nau na em i putim paia, na bilum bilong em i stap wantaim banara na spia. Orait em i kisim ol ring mani bilong tumbuna na liklik dewel pis. Dispela i no dewel pis tru, long tok ples mipela i save kolim SALAM.

Man, man, baga ya i bilas gut tru na em i kisim kundu bilong em na em i go bek long ples.

Long taim em i go kamap long ples, meri na pikinini bilong em i askim em. "Yu kilim abus tu o nogat?"

Man ya i giamanim ol na i tok, "Sori tru, mi no kilim wanpela abus."

Em i no tokim olsem em i bin singsing long nait i go inap tulait. Na ol dispela bilas bilong em tu em i bin haitim pinis long bus na em i go kamap long

ples. Long dispela nait gen, em i tokim meri na pikinini bilong em olsem bai em i go was long mun. Na em i lusim ol i stap na karim bilum bilong em na i go kamap long ples we em i bin singsing.

Em i kamap long dispela hap na em i kisim ol dispela bilas bilong em na em i putim pinis na em i stat long singsing i stap. Em i singsing i go inap em i sotwin na em i go sindaun kaikai buai. Kaikai buai pinis, em i kirap holim kundu na mekim save long singsing gen.

Long taim tulait i bruk man ya i kirap haitim ol bilas bilong em long singsing na em i karim naip, banara, spia na bilum na em i wokabaut i go bek long ples.

Meri na pikinini i ting olsem man ya i go was i stap long bus na bai em i kilim wanpela abus na karim i go bek long ples. Tasol nogat. Ol i lukim man ya i go kamap han nating.

Ol i askim em, "Yu kilim wanpela abus tu o nogat?"

Man ya i no save olsem meri bilong em i bihainim em i go. Na em i taitim bus rot i go kamap long hap ples we em i save haitim ol samting bilong singsing long en.

Meri bilong em i hait i stap na em i lukim man ya i kirap ksim ol samting ya na em i bilas pinis na i

hatim singsing i stap.

Meri bilong em i lukim na em i belhat tru, na i tok, Aha, nau mi save long ol kusai bilong dispela les man. Em i save giamanim mipela na kam hia long singsing."

Meri ya i lukim pinis na em i tingting long trikim man bilong em. Em nau meri ya i go kisim graun malumalum na putim long skin bilong em. Na em i wokabaut isi isi i go long hap we man ya i singsing i stap.

I gat wanpela diwai i stap klostu olsem na meri ya i go antap isi tasol long diwai ya. Man ya i hatim singsing i stap na klostu skin palai long kundu bilong em i bruk.

Meri ya i go antap pinis long diwai na em i senisim nek bilong em na i singaut, "Ha, man bilong mi yu singsing i stap. Nau bai mi kaikaim yu stret. Yu abus bilong mi."

Meri i givim dispela hap tok i go pinis na em i kalap i go daun klostu long man ya. Man ya i singaut nogut tru na em i guria wantaim na ranawe i go pundaun na singaut wantaim i go.

Em i no tingting moa long ol bilas bilong em. Em i harim meri i singaut na em i ting ating wanpela dewel meri tru i raunim em. Na long taim em i ranawe em i bin krungutim ol ring mani na salam na brukim ol dispela samting.

Meri bilong em asde yet i go kamap long haus na em i waswas na rausim ol graun malumalum long skin bilong em. Em i go insait long haus na tokim tupela pikinini bilong em.

"Dispela papa bilong yupela i save giamanim yumi long go painim abus tasol em i save go singsing long bus."

I no longtaim nau na ol i harim papa bilong ol i sotwin nogut tru na i go kamap long haus. Em i wok long paitim dua na singautim ol long opim. Ol i harim pinis na ol i giaman long pulim win strong i stap.

Papa bilong ol i wok long singaut, "Opim dua, dewel meri i raunim mi. Hariap na opim dua."

Em nau bikpela pikinini bilong em i kirap i go na opim dua long papa bilong em. Papa i kam insait long haus na em i tokim pikinini bilong em long pasim dua.

Ol i giaman na askim em, "Devel i raunim yu long wanem hap tru?"

Papa bilong ol i kirap na tok olsem em i sindaun was i stap long mun na tewel meri i sindaun antap long diwai na i lukim em. Olsem na dewel ya i kalap i kam daun na raunim em i go long kaikaim em.

Long moning taim man ya i tokim meri na tupela pikinini bilong em, "Yupela i stap bai mi go lukim ol samting mi lusim i stap long bus. Devel i ranim mi na mi no tingting long kisim ol dispela samting."

Long taim man ya i go pinis mama i kirap na i tokim ol pikinini bilong em olsem, "Em i giaman ya. Em i laik go lukim ol ring mani na kundu na salam bilong em. Em i bin ranawe long nait na ating em i mas brukim olsem na em laik go na sekap long ol dispela samting."

Man ya i go kamap long ples we em i bin hatim singsing long nait na em i lukim ol samting bilong em i bruk bruk nabaut na slip i stap. Tarangu ya i lukim olsem na em i no toktok. Em i wari nogut tru na em i kisim tasol bilum, naip, banara, spia na em i wokabaut i go bek long ples bilong em.

Long taim em i kamap long ples, meri bilong em i kukim kaikai pinis na em i sindaun tanim saksak i stap. Man ya i go isi tasol na em i sindaun i stap. Na long taim meri bilong em i laik lindaun em i lukim hap graun i pas i stap long sait bilong wanpela susu bilong em.

Man ya i lukim olsem na em i save pinis olsem em meri bilong em tasol i bin giamanim em long nait. Man ya i belhat nogut tru long wanem em i wari long kundu na salam na ol ring mani bilong em i bin bruk long taim em i bin ranawe long nait. Em i no toktok, em i stap isi tasol. Na long taim ol i kaikai na taim



meri bilong em i sutim kaikai na ol i sindaun kaikai.

Wanpela taim nau dispela man i tokim ol pikinini bilong em olsem em na mama bilong ol bai go long bus long kisim ol galip. Em i singautim ol pikinini i kam na i tok, "Yupela i stap. Mitupela mama bai go long bus na kisim ol galip. Kandere bilong yupela i laikim sampela na em i salim tok i kam."

Tupela marit ya i wokabaut i go kamap long ples we ol galip i sanap long en. Orait, man ya i katim mambu pinis na em i pasim huk long en na em i wok long brukim ol galip long diwai. Na meri bilong em i go antap long diwai na em i wok long brukim ol galip i stap antap.

Long taim man ya i hukim olgeta galip pinis em i singaut i go long meri bilong em, "Hoi, yu stap we?"

Tarangu meri i harim na em i ting man i askim tasol na em i bekim.

"Mi stap hia bai mi mekim nois na yu lukim."

Man bilong emi lukim pinis na em i kirap kisim mambu bilong em i go tasol na sutim meri stret long sol bilong em. Mambu i go kamap long narapela sait na meri ya i singaut wanpela taim tasol na em i pundaun i go daun long graun na em i dai.

Man bilong emi lukim meri i pundaun nau a em i salim wanpela palai i go sekap long meri. Em i tokim palai olsem sapos meri ya i dai tru orait palai i mas kisim blut long nus o maus bilong meri ya i go soim em.

Palai i kisim blut i kam soim man ya nau na man ya go daun long galip diwai na em i go kisim bodi bilong meri bilong em i go putim long as bilong galip diwai.

Em i putim bodi bilong meri bilong em pinis na em i kisim ol galip i kam na putim raun long bodi bilong meri. Pinis nau na em i kirap na katim susu bilong meri bilong em na karim i go bek long ples.

Em i go kamap long ples na em i tokim ol tupela pikinini, "Mama i karim ol galip i go givim long kandere bilong yutupela, Olsem na yutupela i mas kukim

dispela talinga bilong mi."

Tupela pikinini i kisim dispela karamap em papa bilong ol i givim na tupela i karim i go insait long haus. Tupela i lusim rop na long taim ol i opim karamap ya ol i lukim susu bilong mama bilong ol i stap insait long en.

Ol i lukim olsem na ol i no kukim. Tupela i larim i stap. Na long nait yet tupela i go askim kandere bilong ol sapos mama bilong ol i karim sampela galip i go long givim em. Tasol kandere bilong ol i tokim tupela olsem mama bilong ol i no bin karim galip i go long haus bilong em.

Tupela pikinini i harim olsem na ol i go bek long haus bilong ol. Ol i slip i go tulait nau na ol i go long dispela hap we papamama bilong ol i bin go kisim galip.

Long taim ol i go kamap long dispela ples, ol i lukim bodi bilong mama bilong ol i slip i stap long as bilong galip. Na ol i lukim ol galip i raunim em i stap. ol i lukim olsem na ol i wari long mama bilong ol na ol i krai nogut tru.

Ol i no tokim papa bilong ol long dispela samting. Long wanem oli save olsem papa i belhat long mama bilong ol na em yet bin kilim em.

Ol i stap tasol wantaim papa bilong ol i go i go na papa i ting ol pikinini bilong em i lusim tingting pinis long mama bilong ol. Orait wanpela de nau papa bilong ol i tokim ol.

"Ol pikinini, tumora bai yumi go long gaden na kukim ol pipia."

Em nau long moning ol tripela wantaim i kirap na ol i go long gaden. Ol i go kamap long gaden na ol i stat long mumutim ol pipia na laitim paia. Na papa bilong ol i planim ol taro, kon, yam, bin aibika na ol sampela arapela kaikai.

Ol i wok i stap long gaden inap belo. Na papa bilong ol i wok long planim ol kaikai i go na nek bilong em i drai. Na em i singaut i go long ol pikinini bilong em, "Hoi, nek bilong mi i drai ya. Inap yutupela i go kisim wari i kam?"

Tupela pikinini bilong em i harim tok tasol. Na tupela i laik bekim dinau bilong mama bilong ol.

Orait, tupela i go insait long bus nau na liklik susa i tokim bikpela susa, "Nau papa i mas dai."

Tupela i katim mambu pinis nau, orait, liklik susa i go painim sentipit. Em i painim wanpela na em i karim i kam na putim i go insait long as bilong mambu. Bikpela susa i krai long papa bilong em olsem na em i kisim grasopa i stap insait long mambu Eilam.

Tupela i pulmapim wara pinis na tupela i karim i go long gaden. Oli go kamap long gaden na bikpela susa i singaut i go long papa bilong ol, "Papa yu kam kisim wara bilong yu na dring."

Tasol liklik susa i toktok strong long papa bilong em i mas kisim mambu wara bilong em na dring. Orait papa i lukim olsem na em i kirap i go na kisim mambu wara long han bilong liklik susa na em i dring.

Papa i no save olsem dispela sentipit em liklik meri ya i bin putim long wara i go daun pinis long bel bilong em. Orait, bihain em i kisim mambu wara bilong bikpela pikinini na em i dringim tu wara long en.

Long taim em i dring wara, dispela elam i bin go daun wantaim wara long bel bilong em na em i pilim lek, han na nek bilong em i wok long skrap. Tasol em i ting ating ol pipia i stap long wara i mekim na nek bilong em i wok long skrap olsem.

Dispela elam na sentipit i no dai. Em nau man ya i sanap liklik na em i pilim pen long bel bilong em. Em dispela sentipit i wok long kaikaim bel bilong em.

Ol i kaikaim bel bilong em i go inap long lewa bilong em nau na man ya i dai. Orait, tupela pikinini bilong em i kisim em i go na ol i planim em long gaden bilong ol. Na bihain tupela i go bek long ples bilong ol.

Kandere meri bilong mi i bin stori long taim mi stap long ples Maui long Lumi, Wes Sepik Provins.

**William Jimmy Sabien, C/- Hubert Woflu, 2 PIR B Coy, Moem Barek, Wewak, ESP.**

## Glasim gut ol dispela piksa.

Olgeta yet i luk wankain tasol. Sapos yu lukluk gut bai yu painim tupela tasol i wankain. Makim ol ansa wantaim X.

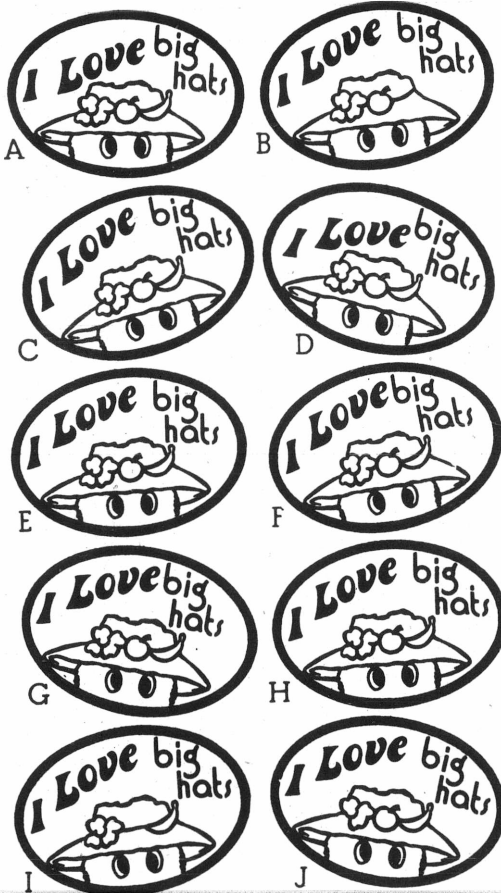





**Kepten bilong Waliya soka tim, Ibowato Palo (Iephan) i kisim tropi long kamap namba tu sempian tim insait long gren fainal bilong Boroko Motors Kap soka resis. Palo i kisim tropi i kam long han bilong Misis Young, em meri bilong Mista Keith Young. Waliya i bin lus 3-1 long penalti skoa i go long Rapatona tim.**

**Waliya Enitaim**

# Rabaul Strong Tumas

**MOA long 5,000 pipel bilong Madang i bin lukim marila bilong ol Tolai i bin autim blak pawa bilong Arawa 10-2 long nesanel sofbal sempionsip gren fainal long Ista Mande.**

Rabaul i bin lokim gut tru tim bilong Arawa long dispela tru stail sofbal bilong man, em i bin kamap long bikpela Laiwaden graun insait long Madang taun yet.

David Susame, husat i bin lukim dispela gren fainal i tokim Wantok olsem dispela 3-pela tim i bin go insait long ol fainal, em Arawa, Mosbi na Madang i bin surik tru na pret long tim bilong Rabaul.

Mosbi i kisim namba 3 ples long Madang i stap long namba 4 ples insait long sempionsip fainal. Na ol dispela 3-pela tim i lukim pinis stail nateknik bilong ol Rabaul pilaia. Long wanem tim bilong Rabaul i bin hat tru na i mekim ol tim long arapela senta i pret olgeta long ol dispela Tolai.

No gat pitsa i pilai olsem Iman Christop bilong Rabaul. taim emi pits, bal i lus nating long ai bilong ol Arawa bata. Bal i go pinis na bata i tuet long wingim bat. Dispela i bin bikpela asua tru i mekim Arawa i lus.

Na bating bilong ol Arawa tu i bin strong tasol oli bin asua long salim bal i go long glap bilong ol Rabaul filda. Dispela asua i mekim na no gat sans long ol bata i ran i go long bes.

Na ol Rabaul i no painim hat. Bata bilong ol i wok long salim bal strong tru i go aut long graun tasol. Oli no paitim mas abrusim ol filda bilong Arawa tim.

Dispela kain pilai i mekim Rabaul i wok long go pas yet long namba wan inap long namba 4 ining. Skoa i bin sanap Rabaul 8 na Arawa i karim kiau yet. Klostu long namba 5 ining nau wanpela bata bilong Arawa i hamaim bal i go aut long graun abrusim namba tu bes filda. Na dispela i bringim 2-pela rana i stap long bes i ran i go long hom plet. Na tu dispela las skoa bilong Arawa i mekim na skoa i sanap Rabaul 10 na Arawa 2.

Bihain long pilai Kosa bilong Arawa, Steven Mesmin i tokaut olsem i tru ol bata bilong tim bilong em i tuet long swingim bat olgeta taim Iman Christop bilong Rabaul i pitsim bal. Dispela i bin mekim na Arawa i lus long dispela gren fainal.

Na tim kepten bilong Rabaul tim, Steven Tobunbun i bin tok bihain long pilai olsem oli bin pret liklik long tim bilong Madang. Tasol

taim Arawa i kamap long gren fainal, em i luk olsem bai Rabaul i win isi tasol. Na em i glasim tu pinis bipo yet olsem bai ol i winim dispela sempionsip.

Rabaul i bin stat pilai insait long Nesanel Sempionsip long 1978. Na ol dispela taim oli lus 3-pela taim. Na nau long namba 4 taim oli win.

Rabaul tim i gat ol gutpela Nesanel pilaia na oli no gat wari tumas. Tasol Arawa i painim hat long wanem planti ol pilaia bilong oli yangpela na i no bin kamap long wanpela Nesanel Sempionsip yet. Na dispela taim em namba wan taim tru bilong oli. Tasol Kosa Steven Mesmin i tok maski oli i lus na no gat nesanel pilaia i stap long tim, tasol oli amamas tru long kamap long gren fainal.

Dispela yia win i senisim rot bilong em las yia Arawa na Rabaul i bin kamap long namba 3 na 4 ples. Na Madang i go daun long Mosbi long gren fainal. Tasol nau dispela 4-pela tim i senisim ples. Madang na Mosbi i kisim ples bilong Arawa na Rabaul las yia.

Long dispela yia 12-pela tim bilong ol man na narapela 12-pela tim bilong ol meri i bin i stap long Madang Sempionsip. Na 12-pela provins olgeta i bin salim tim bilong man na meri i go long Madang long dispela sempionsip.

Oli i bin skelim ol dispela tim olsem, pul 1, Madang, Lac, Oro, Mendi, Arawa na Manus. Na long pul 2 Rabaul, Sta Maunten, Goroka, Wewak, Vanimo na Mosbi.

Long Pul 1. Tim bilong Madang na Manus ib in strong tru long pilai. Madang i bin winim Manus 6-5. Tasol Madang i bin win long 2 pesen tasol em oli i bin glasim long gutpela pasin Madang i bin pilai.

Na long Pul 2, Mosbi na Wewak i bin strong-pela tim tru. Tasol Mosbi i daunim Wewak long kamap long semi fainal. We Mosbi i pilai wantaim Madang long kisim namba 3 ples.

Oli eksekutiv bilong sofbal i no bin tokaut yet long wanem provins, bai Nesanel Sempionsip bilong 1985 i kamap.

# Mosbi Autim Taitel

**OL meri Mosbi i daunim Lae 7-5 long Nesanel sofbal Sempionsip gren fainal long Madang.**

**Pauline Laki**

Mosbi i no gat wari tru olsem tim kosa bilong ol Auvita Tua i tok ol pilaia bilong Mosbi em ol Nesanel taitel pilaia tasol. Na oli i mekim gut tru ol pilaia i kam long ol 8-pela A gret tim bilong Mosbi sofbal yet.

Olsem na Mosbi i gat gutpela as tru long autim dispela Sempionsip taitel long Madang. Pitsa kepten Florence Bundu na namba tu kepten na pitsa Emma Kalas i stiaim gut tru tim bilong oli.

Long namba wan 4-pela ining Mosbi i bin go pas na long dispela taim nau. Pastaim yet long stat bilong pilai Mosbi i wok long go pas inap long namba 4 ining na Lae i skoim narapela 5 ran. Dispela i mekim tupela tim i dro 5-5. Tasol klostu long las ining nau Mosbi i skoim narapela 2-pela ran gen long winim dispela sempionsip.

Madang i bin autim Wewak long kisim namba 3 ples. Dispela i larim Wewak i sanap long namba 4 ples insait long

ol fainal.

Mosbi i bin pilai long pul 2. Na ol dispela pilaia bilong Mosbi i no meri nating. Oli Eksekutiv i bin glasim gut tru long makim ol bikpela nem pilaia tasol. Olsem na oli i autim olgeta tim insait long pul 2 long kamap long fainal. Wewak em i bin wanpela strongpela tim Mosbi i no bin daunim isi insait long dispela pul.

Na long pul 1, Lae i bin strong tru long daunim pawa bilong Madang asples yet long salensim Mosbi long gren fainal.

Las yia Mosbi i bin sempion tu na Madang i kisim namba tu ples. Kosa Auvita Tua bilong Mosbi i tokaut olsem ol pilaia bilong Mosbi tim i save pilai 'klasi' sofbal na oli i go bilong win tasol. Olsem na nau gen oli i kamap sempion yet.

Stat long Ista wiken Fraide, yet olgeta pilaia bilong ol dispela 12-pela provins i bin amamas tasol. No gat kros obelhat i go kam long ol arapela tim.

Long olgeta tim i bin gat ol Tolai pilaia yet i stap. Na taim narapela senta i pilai ol Tolai bilong narapela timi sapotim dispela tim. Olsem taim Rabaul i kisim Arawa long gren fainal bilong ol man bikpela sapot i kam long Rabaul tim tasol long olgeta kona bilong ples bilong pilai.

Long wanem moa

Tolai sofbal pilaia i bin stap long ol arapela tim na olgeta yet i sapotim Rabaul tim. Dispela i mekim lewa bilong Rabaul tim i sut moa yet long winim dispela pilai.

Long gren fainal bilong ol man Jonbili Tokome i bin lukautim pilai. Oli eksekutiv yet i makim Jonbili long ampaiya long dispela gren fainal.

Na Joan Bampton i bin ampaiya long ol fainal na gren fainal bilong ol meri. Long olgeta sofbal sempionsip oli eksekutiv i save kaunim Bampton yet long ampaiya long ol hatpela pilai.

## Mosbi Osi Ruls Sisen

### Kik-Op Dro

**SARERE 28 EPRIL, 1984**

Taim	Gret	Tim	Graun
11.00	Kolts	Mosbi V Difens	Boroko
1.00	A Res.	Mosbi V Difens	Boroko
3.00	A Gret	Mosbi V Difens	Boroko
11.00	Kolts	Boroko V Yuni	Amini
1.00	A Res.	Boroko V Yuni	Amini
3.00	A Gret	Boroko V Yuni	Amini

**SANDE 29 EPRIL, 1984**

11.00	Kolts	Wes V Koboni	Boroko
1.00	A Res.	Wes V Koboni	Boroko
3.00	A Gret	Wes V Koboni	Boroko





Kepten bilong Yuni tim, Joe Turia i kisim draipela Hara Kap long han bilong Mista Keith Young.

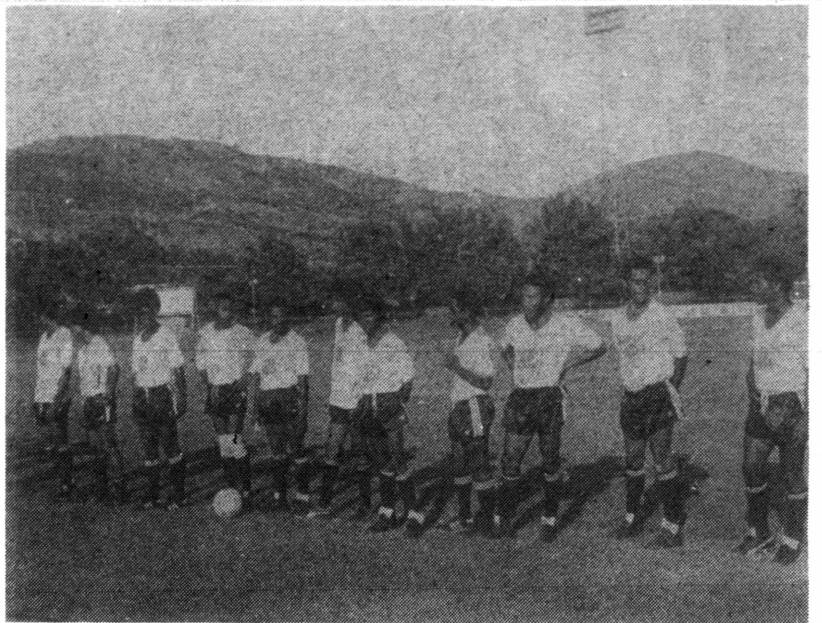

Hia em i lain pilaia bilong Yuni husat i sempion bilong 1984 Hara Kap soka resis. Kas bilong ol!

## Soka - Hara Kap Nokaut

T'ngau 5 GFC 4  
Yuni 5 Waliya 0  
R'tona 2 Sobou 0  
K'wina 4 Wanzesi 3  
Watani 2 Korion 1  
Murat 3 B. Kumul 0  
Kunta 2 Air Niugini 1  
Sunam (1) 6 Blu Kumul (2) 1

**Kwata-fainal**  
21/4/84

Yuni 7 T'ngau 0  
R'tona 3 - Kiriwina 1  
Watani 3 Murat 1  
Sunam 3 Kunta 1

**Semi-fainal**  
22/4/84

Yuni 4 R'tona 1  
Watani 3 Sunam 1

**Gren fainal**  
23/4/84  
Yuni 5 Watani 1

## Mosbi Sariti Soka

**SOKA pilai bilong Hara Kap resis long Mosbi i pinis. Tasol Mosbi Soka Asosiesen bai putim kamap tripela Sariti soka pilai bilong 1984 insait long Bisini ples pilai long dispela Sande Epril 29.**

Ol i kolim dispela nem "Sariti," bikos olgeta mani i kamap long get bai go long helpim dispela 4-pela Sariti oganaisesen: 1. Ret Kros, 2. Sesia Homs, 3. Sen Jon Embulens na 4. Pilai Spot bilong ol tarangu manmeri.

Dispela namba wan pilai bilong ol meri bai kamap inap 60 minit olgeta, em 30 minit long namba wan hap na 30 minit gen long seken hap. Namba tu pilai bai go inap long 70 minit na Sariti soka pilai bai go

inap long 90 minit olgeta. Guria husat i wina bilong Lig soka fainal bai traime bun bilong Rapatona husat i Lig sempian. Dispela tupela tim i holim ol dispela taitel insait long 1983 sisen.

Presiden bilong Mosbi Soka Asosiesen, Paul Soweni yet i makim ol pilai insait long dispela President's 11 tim bilong em. Na ol dispela 14 pilaia em: Abel Ilaita, Demas Ilaita na Simon Dobin (GFC) Andrew Maram-pau (Difens) Roy Kisapai (Sunam), John Mogi na Philip Wori (Yuni), Sabina Kone na Buka Pasar (T'ngau), Mike Pye na Tim Moore (Wanazesi), Bobby Hemboring (Mopi), Muaki Baboi (Kunta) na Robin "Supaman" Pomaliu bilong Watani.

### Progrem bilong dispela Sariti soka pilai:

1.00pm Meri: Combined R'tona/Yuni V Combined Waliya/Kula  
2.15pm Man: President's 11 team V Ex-Internationals team  
4.00pm Sariti soka pilai: Guria V Rapatona

Na 17 pilaia insait long Ex-Internationals tim, em Robert Popat, Samar Asugum, Muraba Monagi, Tikio Piska, David Kambe, Mark Basausau, Julius Posing, Stalin Jawa, Leo Kusunan, John Davani, Kanawi Popal, Wellington Jojoga, Malakai Kupesan, Ila Ilaita, James Samol, Andrew Waho na Matthew Raka.

Ol dispela pilaia i mas bung long GFC Klap haus long dispela Fonde, Epril 26, 1984. Dispela bung i bilong stretim tim na putim ol pilaia insait long posisen ol i mas pilai long en.

Vita Drinks i sponsa bilong dispela Sariti soka pilai. Na olgeta manmeri go long lukim pilai bai lusim 50 toea tasol long baim get.

# Yuni winim 1984 Hara Kap

Ben Wauns

**BIKPELA gren fainal soka pilai bilong Hara Kap resis insait long Mosbi i lukim Yuni i daunim Watani 5-1 insait long Sir Hubet Mari Stedium long Ista Mande.**

Moa long 1000 manmeri husat i lusim K1.00 long gent na i go lukluk long dispela pilai i amamas long lukim Watani i pait strong i go i go na lus long Yuni. Planti bilong ol dispela manmeri i lukim pilai, tasol ol i no kliia olsem em i namba 9 taim bilong Yuni i holim pasim dispela Hara Kap.

Yuni i winim Hara Kap wantaim K500 praismani long kamap sempion na Watani i kisim K250. Sunam husat i sanap long namba tri ples insait long dispela soka resis i kisim K150 na Rapatona i kisim K100 long kamap namba 4.

Planti sapota bilong Watani i amamas tru long lukim dispela tim bilong ol i kamap long gren fainal. Long wanem Watani em i wanpela tim husat i stap insait long 4th Divisen. Tasol ol i bin winim olgeta gem bilong ol insait long Pul 7 resis i kam inap long ol fainal na goinsait long gren fainal pilai.

Yuni husat i gat bin-knem long dispela Hara Kap resis na Mosbi Soka kompetisen tu i bin winim olgeta pilai insait long Pul 3 i kam inap long

gren fainal. Na taim ol i bungim Watani insait long ples pilai, ol pilaia i soim kain kain pilai mabel na trik trik nabaut.

Ol lain pilaia bilong Watani husat i nupela long kamap insait long dispela draipela resis i pilai smat, tasol ekspisierens bilong ol Yuni pilaia i moa yet. Olsem na ol i daunim Watani isi tru.

Insait long namba wan hap bilong pilai, ol pilaia bilong tupela tim wantaim i kikim bal isi na skelim strong stail bilong birua. Bal i no pairap strong na ol sapota i no meknais. Dispela skin dai stail bilong pilai isi i mekim planti manmeri i les tru long lukim pilai.

Straika bilong Yuni, Joe Saliu husat i sanap long insait-lep long fowatlain i kirapim ensin na pairapim bal long namba 8 minit, namba 10 na 11 minit i go long gol mak bilong Watani.

Namba wan bal i go anka long, han bilong Tommy Aisome, golkipa bilong Watani. Namba tu traime bilong em i sut i go stret long het bilong gol mak, tasol Aisome i kalap na hamaim bal i go abrusim kros-ba na go ausait.

Namba tri bal i flai long 5 mita mak longwe long gol pos i go insait long umben na Yuni i amamas long putim namba wan gol. Tasol reperi, Michael Vee i soimaut olsem Saliu i opsait na em i no kaunim dispela gol.

Insait long dispela taim, bal i no go insait long hap bilong Yuni. Long wanem lain midfil na fulbek bilong Watani i tingting long banisim mak na i no salim bal i go long fowatlain bilong ol.

Na lain fulbek na midfil pilaia bilong Yuni i kam bung wantaim fowatlain bilong ol na "wokim haus" insait long teritori bilong Watani.

Long 13 minit insait long namba wan hap yet, Joe Turia husat i senta fulbek bilong Yuni i givim siksti wantaim bal i go sait-step na salim bal i go insait long mak bilong Watani. Tasol kipa Aisome i kalap olsem urita bilong asples Mussau Ailan stret na hakim bal long graun na slip antap long en.

Tasol stail bilong urita i popaia liklik na i no tambuim namba wan gol em lep-winga bilong Yuni, Malakai Kupesan i putim i go insait long net long 25 minit bihain long kik-op.

Dispela namba wan gol bilong Yuni i mekim lain pilaia i skin kirap na i no pilai slek moa. Ol sapota long ausait i wok long paitim han na singaut na bal i stat long pairap strong liklik. Na kepten bilong Watani, Kanawi Parkop i kirapim ensin tu na pulimim lain pilaia bilong em i go antap long eria bilong Yuni.

Watani i no abrusim midfil bilong Yuni na pretim Robert Popat husat i bosim gol mak. Popat i wok long sanap nating na ai bilong em i slip bikos em i no holim bal insait long 30 minit bilong dispela namba wan hap bilong pilai. Tasol em i wekap insait long 40 minit mak taim Robin "Supaman" Pomaliu bilong Watani i slekim bal olsem roket bom stret i go long raithan sait bilong umben.

Sapos Popat i no bin kalap kwiktiam, sori

tumas, em bai Watani i gat wan gol. Popat i bin hetwin na holim pasim bal long graun klostu long pos.

Pilai i go het yet na bal i go kamap long gol eria bilong Watani. Raitmidfilda bilong Watani, Daniel Poli i krankitru na hamaim baksait bilong Lungol Popeu wantaim su. Popeu husat i narapela straika bilong Yuni i pulim bal i go kamap 5 mita longwe long mak. Dispela asua i kamap insait long penalti bokis na John Sirigoi, raitfulbek bilong Yuni i kisim penalti kik.

Sirigoi i givim hatwan long bal na golkipa Aisome i kalap na hamaim bal long tupela han. Tasol bal i kalap lusim han bilong em na pundaun isi tru i go daun long baksait na ran i go pas long umben. Dispela gol i mekim Yuni i go pas 2-0.

Dispela penalti gol bilong Sirigoi i kamap long 43 minit mak stret. Ol i pilai inap long narapela 2 minit na kisim malolo bilong hap taim. Na tupela tim i no gat pilai i senisim poroman insait long namba wan hap bilong pilai.

Lain pilaia bilong Watani i go insait gen long seken hap na i no westim taim. Ol i pilai strong moa na karim bal i go traime mak bilong Yuni tupela taim insait long 5 minit tasol. Bal i abrus liklik na go ausait.

Kanawi Parkopi wok long pilai smat moa na helpim Silas Malasine, Billy Pranis, Tapas Popeu na Robin Pomaliu long fowatlain bilong Watani long kisim bal i go klostu klostu long mak bilong Yuni. Tasol "stail manki"





Phillip Wori, Koale Papi na Jasper patterson bilong Yuni i banisim ples gut tru na stapim rot. Ol i save kisim gutpela helpim tru i kam long Joe Turia, John Sirigoi na John Mogi long fulbek.

Yuni i lukim Watani i pilai strong na ol tu i yusim stail bilong kisim bal na salim wantu long poroman. Dispela stail i mekim ol pilai bilong Watani i ran bihainim bal i go i kam na sorwin.

Orait. Joe Saliu gen i skoim namba tri gol bilong Yuni insait long 13 minit bilong seken hap. Biknem bilong dispela gol i mas go long Lungol Popeu husat i slekim bal long raitan kona i kam pundaun stret long lek bilong Saliu klostu long maus bilong gol mak. Yuni i go pas 3-0 na oligo het long mekim stail bilong pilai mabel na kisim bal i go insait long gol eria bilong Watani hariap tru.

Malakai Kupesan, Lungol Popeu, Joe Saliu wantaim Donai Bauai long fowatlain bilong Yuni i pilai smat moa na salim bal i go kam na ran i go insait long hap bilong Watani wantaim bal. Tasol ol i bin popaia tripela taim na abrusim gutpela sans bilong putim gol.

Donai Bauai i yangpela pilai bilong Goidala stret. Em i save pilai straika wantaim Anda 19 tim bilong Yuni. tasol kain smatpela pilai bilong em

insait long dispela gem i apim nem bilong asples bilong em. Bikos em i wanpis bilong distrik bilong em long kisim biknem nau long soka pilai. Em i bin traim mak tripela taim na golkipa bilong Watani i ketsim bal.

Long 25 minit insait long seken hap, Luke Dindillo i go insait long ples pilai na kisim ples bilong Malakai Kupesan husat i kisim bagarap long lek na i no ran gut. Na bihain liklik, Malai Kekesan i go kisim ples bilong John Mogi. Man! Dandillo i go pilai inap long 5 minit tasol na putim namba 4 gol bilong Yuni. Orait. Yuni i go het 4-0.

Dindillo i skoim narapela gol gen bilong Yuni insait long 40 minit mak na mekim Yuni i gat 5 gol. Tasol dispela gol bilong em i kamap 5 minit bihain long taim Kanawi Parkop i skoim namba wan gol bilong Watani insait long 35 minit mak. Orait. Skoa i sanap 5-1 nau.

Olgeta pilai bilong Yuni i banisim rot bilong Watani na i wok long putim bal insait long hap bilong Watani oltaim. Lain straika bilong Yuni i traim mak gen inap long tripela taim, tasol bal i anka long han bilong golkipa. Na long namba 4 traim, Joe Saliu i bamim lek long bel bilong Watani golkipa na tarangu i kisim nogut.

Olopisa bilong Sen Jon Embulens i go insait long ples pilai na helpim long karim dispela golkipa i go ausait. Na Abraham Sikon husat i risev pilai i go kisim ples. Tasol pilai i go het na i no gat gol i kamap. Na dispela pilai i pinis stret long 10 minit pas 6 klok na ples i tudak.

Kepten bilong Watani, Kanawi Parkop i kisim tropi na praismani bilong kamap namba tu sempion. Na Joe Turia bilong Yuni i kisim bikpela Hara Kap wantaim K500. Mista Keith Young husat i bin kisim liklik medal na setifiket bilong kamap laip-memba bilong Mosbi Soka Asosiesen i givimaut ol dispela prais.

Risev golkipa bilong Yuni, Moses Murray husat i no bin pilai i amamas tru long tim bilong em i winim Hara Kap. Na em i tok, "Dispela Hara Kap i bin lus long haus bilong mi inap long wan yia olgeta na i gutpela tru long em i mas i go sanap long ples em i sindaun long en bipo. Na em i namba 9 yia nau long dispela kap i stap long han bilong Yuni."

Dispela win bilong Yuni i winim rekot stret. Bikos ol i skoim 62 gol olgeta insait long dispela Hara Kap resis. Na ol birua bilong ol i skoim 6-pela gol long ol.

Long 1974 i kam inap long 1977, em Yuni i bin winim dispela pilai resis. Long dispela taim ol i kolim nem ista kap resis-



Sempion straika bilong Sunam, Kanawi Popal (raitan) i traim long kisim bal, tasol Robin "Supaman" Pomaliu bilong Watani i tantanim bal olsem liklik mabel na trik trik. Ol i bin dro 1-1 tasol Watani i winim Sunam 3-1 long penalti soka.

na Mosbi Soka Asosiesen i sponsa bilong dispela kap. Soka resis bilong dispela kap i no bin kamap long yia, 1978, bikos ragbi lig resis bilong kembri kap i kamap long Mosbi.

Long 1979 i kam inap nau, Mista Hans Rademacher i kamap wanpela

bosman bilong PNG Color Lab na larim dispela kampani i sponsa long Hara Kap. Na long 4-pela yia namel long 1979 i kam inap long 1982, em Yuni tim tasol i holim pasim dispela kap.

Difens i winim dispela Hara Kap long las yia, 1983. Na nau Yuni i kisim

bek dispela kap. Dispela rekot bilong holim pasim kap inap 9-pela yia i winim rekot bilong ol arapela tim insait long PNG na tu long ol biknem tim bilong arapela kantri bilong wol husat i gat soka pilai long en.

## Boroko Netbal I Stat

Dispela Sarere, 28, Epril Boroko Netbal Asosiesen bai mekim (Raun Robin) pilai insait long dispela wanpela de greting mats bilong ol long Boroko, Bisini graun netbal kot.

Seketeri bilong Asosiesen, Pole Kasman i kisim nem na rejista mani bilong 55 netbal klap pinis. Na emi tok dispela Sarere bai em i kisim moa nem bilong ol klap. Dispela sisen bai 96 tim tasol i pilai.

Na long dispela namba bai oli katim daun i go long 3-pela divisen A.B na C. Na pilai tru bai stat long 5, Me.

# Em i gutpela pasin long lukautim gut yu yet.

Maski yu pilai o wok, ol meri bilong tude i ken i stap isi na nogat heve. **Johnson & Johnson** i gat oi gutpela samting. Em yu ken putim, o yusim oieta de na nogat wari long em.



# Johnson & Johnson





**PUNJAP - INDIA** — Ol dispela lain i karim ol gan na was long lida bilong ol Jarnail Singh Bhindranwale (namba 4 long lephan). Ol ripot i tok olsem Bhindranwale i save salim ol lain bilong em i go pait na kamapim trabel long olgeta de.



**HOUSTEN - AMERIKA** — Ol dispela man em ol hap man tu ya. Ol i mekaniik bilong ol roket. Long lephan i go long raithan em Dick Scobie, George Nelson, James van Hoften, Terry Hart na komanda bilong ol Robert Crippen. Ol i bin raun long skai na stretim ol bagarap insait long roket Solar Max na salim dispela roket i go gen.

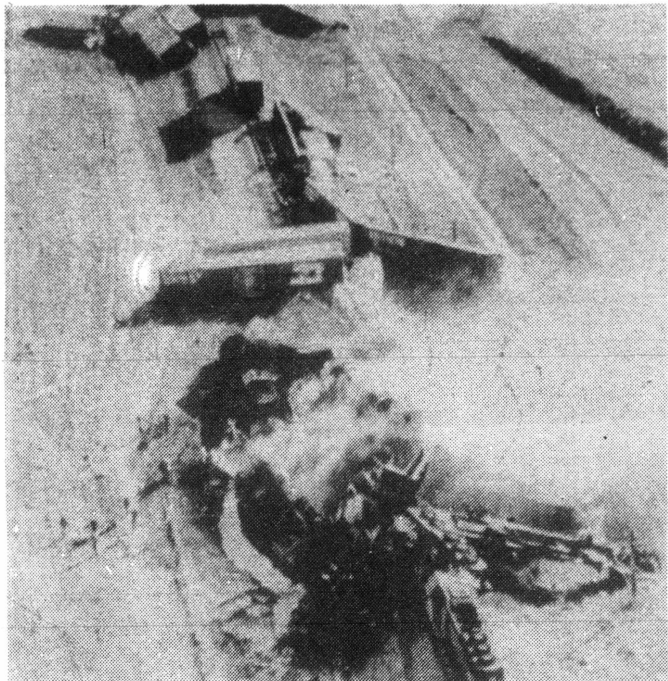

**WIGGIN, AMERIKA** — Dispela poto i soim tupela kago tren i bin bam. Insait long dispela birua, 3-pela pipel i bin dai na 2-pela arapela i kisim bikpela bagarap. Ol i wok long painimaut moa nau long dispela birua.



**ARANYAPRATHET - TAILAN** — Ol dispel apipel i wok long ranawe i go insait long Tailan bihain lon gol lain bilong Vietnam i pait wantaim ol lain Khmer soldia. Moa long 30,000 manmeri na pikinini i bin ranawe i go insait long Tailan long dispela taim.



**PARIS - FRANS 13 Epril** - - Ol dispela wokman bilong wanpela stil faktori long Loren, Frans i bilas olsem sampela bikman bilong kantri Frans na ol i protes. Gavman bilong Frans i tingting long givim hatpela taim long stil bisnis insait long kantri. Olsem na ol pipel ya i protes.



**JERUSALEM** — Tupela soldia bilong Israel i karim ol gan bilong ol na patrol raun long ol srit i stap. Planti ol soldia i wok long sambai long dispela taim long wanem i gat planti trabel i bin kamap.

# Wantok

Digitized version made available by



**Copyright:** Under copyright

**Rights Holder:** Word Publishing Company Limited

**Use:** This digital version is made available from the UC San Diego Library under a license granted by the Word Publishing Company Limited. This digital copy of the work is intended to support research, teaching, and private study.

**Constraints:** This work may be protected by copyright law. Use of this work beyond that allowed by the applicable copyright statute requires the written permission of the copyright holder(s). Responsibility for obtaining permissions for any use and distribution of this work rests exclusively with the user and not the UC San Diego Library. Inquiries can be made to the UC San Diego Library program having custody of the work.

**Note on digitized version:** Some of the digital versions presented here reflects the quality and contents of the microfiche. Problems which have been identified include misfiled or out-of-order pages, illegible text; these problems have been rectified whenever possible.